

S V L A R E S .



AUCTION SALE 160

IMPORTANT NUMISMATIC LITERATURE

*Featuring Material from the Libraries
of Richard E. Margolis, Roger Persichilli,
John Dannreuther and Others*

Saturday, May 22, 2021 • 12:00 P.M.

V S. C. F. C. N. CAESAR
PERPET. R N P T
PERATOR
DIES XV E A
QVO DIE IPSE OCCISVS EST
CAE- SE
II. TI
CAESAR D CT . P. ET
M. N. G EQ . P.
EODEM ANNO.
LENVS. P. VA TINIVS. P. F.
CAE- M. AIMILIVS. M. F. Q
III. LEPIDVS.
CAESAR F. Q. N. LEPI- R.P.C.ETREIG
EODEM ANNO.
CAE- SINE CONLEGACENS
III. E
EODEM ANNO.
MAXI C. TREBONIVS. C. F. ASPER
EST.
C.EST.
C. N.
CAESAR. IV. DICT.
F. Q. N. LEPI- R.P.C.ETREIG
MAG.EQ.
DVS PALVDATVS
M. N.
QVEN-
GNAT.
CAE- M. ANTONIVS. M. F.
R. OC- POS.
EST.
DOLA-
PAN- A. HIRTIVS. A. F. IN
CCIS.E. LIO OCCIS. EST IN
XIII. CVM FACTVSEST.
CAE. Q. PEDIVS. M. IN
VI PO- MORT. F.
AVGV- FACTVS
T ABD. TVSE.
TVSE. INAS.
INAS. P. VENTIVS.
PIDVS. IDEM. Q. PRA

Kolbe & Fanning
Numismatic Booksellers
numislit.com

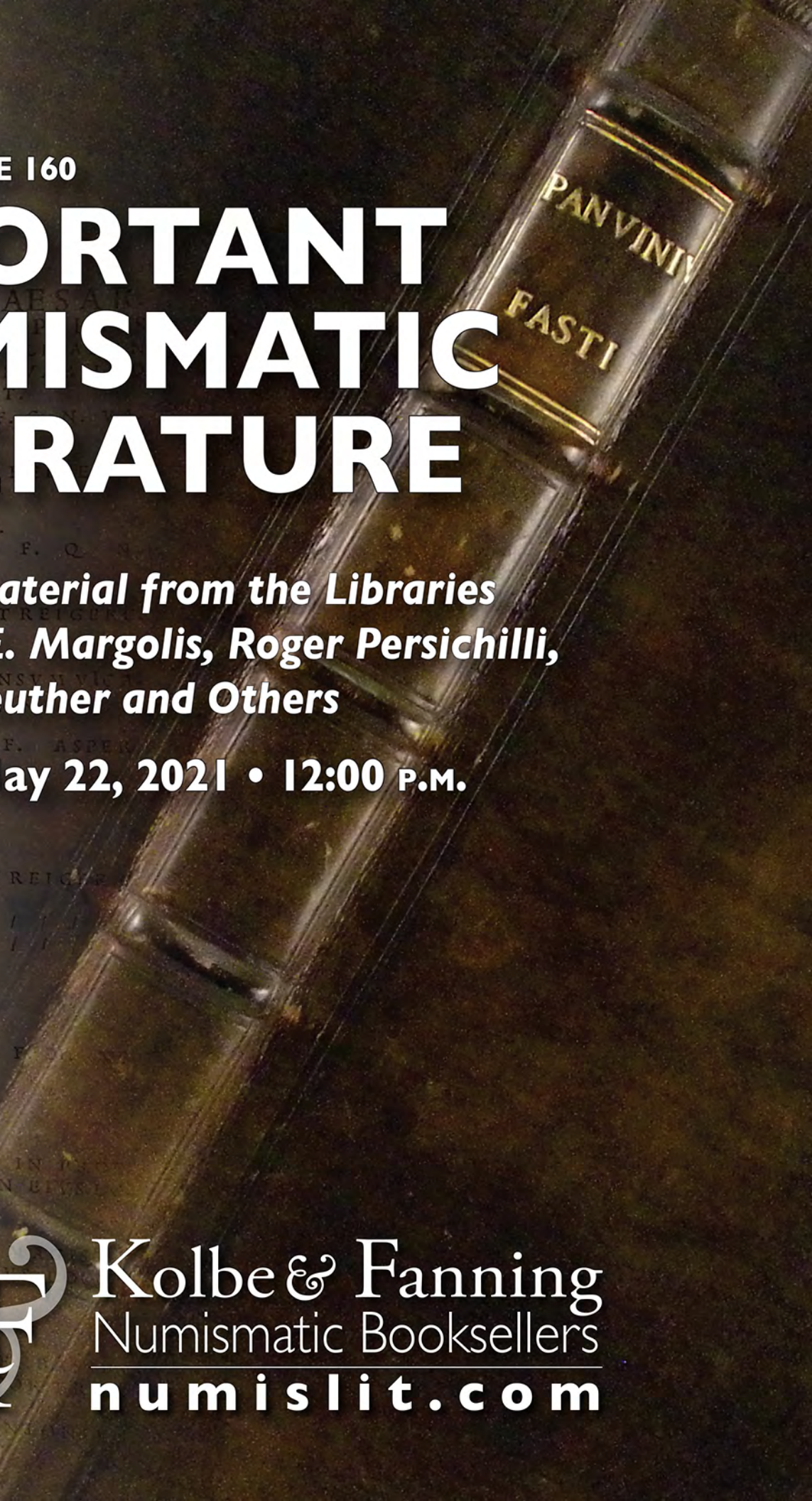

Sale 160

**IMPORTANT
NUMISMATIC
LITERATURE**

*Featuring Material from the Libraries of Richard E. Margolis,
Roger Persichilli, John Dannreuther and Others*

**Mail Bid & Live Online Auction
Saturday, May 22 at 12:00 Noon Eastern Time**

Place bids and view lots online at

BID.NUMISLIT.COM

Absentee bids placed by post, email, fax or phone due by midnight Friday, May 21.
Absentee bids may be placed online at any time before the sale.



Kolbe & Fanning
Numismatic Booksellers
numislit.com

141 W. Johnstown Road • Gahanna, Ohio 43230

(614) 414-0855 • Fax (614) 414-0860 • numislit.com • df@numislit.com



Terms of Sale

1. This is an online and mail-bid sale. **Absentee bids will be accepted by mail, fax, email and phone until the day before the live online sale.** On the day of the live online sale, only bids placed via the live online platform will be accepted: **no phone, fax, email or mail bids can be entered on the day of the sale.**
2. All lots will be sold to the highest bidder at the time of the sale. All bids (whether placed online or by mail, fax, email or phone) will be treated as limits and lots will be purchased below these limits where competition permits.
3. Absentee bidders should be mindful that **bids submitted in irregular increments may be rounded to a lower bid** to comply with the online platform's established bidding increments.
4. Unless exempt by law, the buyer will be required to pay 7.5% sales tax on the total purchase price of all lots delivered in Ohio. Purchasers may also be liable for compensating use taxes in other states, which are solely the responsibility of the purchaser. Foreign bidders may be required to pay duties, fees or taxes in their respective countries, which are also the responsibility of the bidders.
5. This is not an approval sale. Any claims for adjustment by bidders must be made within three days after receipt of lots purchased. No lots may be returned without our written permission. By submitting bids you agree to the Terms of Sale.
6. Bidders unknown to us must supply acceptable credit references or a 25% deposit to assure entry of their bids. Registration of unknown bidders on the live online platform will constitute approval only when the bidder provides an acceptable credit card number with registration.
7. This is a reserve auction. The estimates of value are intended solely as a guide. Starting prices for this sale are at approximately two-thirds of estimate, though this may vary. Kolbe & Fanning reserve the right to purchase items in this sale for customers or stock at their discretion.
8. **A buyer's premium of 20% will be added to the cost of all lots purchased.**
9. We reserve the right to withdraw any lot prior to sale for any reason.
10. All postage, insurance and shipping charges will be added to the buyer's invoice. There will be a \$3.00 charge per lot for processing.
11. A late payment fee of 2% per month will be charged on accounts remaining unpaid 30 days after the sale.
12. This sale is conducted in U.S. dollars. Payment may be made by check, money order, credit card, PayPal or wire transfer. All checks must be in U.S. dollars and drawn on U.S. banks. Our bank account details will be provided on request for wire transfers, and any bank charges must be paid by the sender.
13. Lots to be mailed to addresses not in the United States or its Territories will be sent only at the risk of the purchaser. When possible, postal insurance will be obtained. Packages covered by private insurance will be so covered at a cost of 1% of total value, to be paid by the buyer.
14. Title to all lots remains with the cataloguer until paid for in full. Payment must be made immediately upon notification or upon receipt of material. The discretionary right to withhold delivery of lots until full payment has been received is reserved.
15. All lots are as described. We acknowledge the possibility of errors or typographical mistakes, and any errors on our part will be cheerfully corrected. We cannot be responsible for your errors; please check your bid sheet carefully.
16. Kolbe & Fanning Numismatic Booksellers LLC are licensed by the State of Ohio Department of Agriculture (license 2011000028) as an auction firm, and are bonded as required by law in favor of the State of Ohio.

BOOK SIZES

F° (folio) over 13 inches
4to (quarto) 12 inches
8vo (octavo) 9 inches
12mo (duodecimo) 7–8 inches
16mo (sextodecimo) 6–7 inches
24mo (vigésimoquarto) 5–6 inches
32mo (trigesimosecundo) 4–5 inches

BOOK CONDITIONS

As new — no signs of wear or defects.
Fine — nice clean copy, slight signs of use.
Very good — some wear, no serious defects.
Good — average used and worn book, complete.
Reading copy — poor but readable.
Ex-library — with library identification marks.

Unless stated otherwise, all books are bound; all periodicals and auction sale catalogues are in the original paper covers.

Books without descriptions of condition may be assumed to be nice clean copies in the octavo range.

Sizes are not always noted for auction catalogues and periodicals. All serious defects are noted.

ANCIENT NUMISMATICS

Names on Ancient Persian Coins

1 Alram, Michael. **IRANISCHES PERSONNAMENBUCH. BAND IV. NOMINA PROPRIA IRANICA IN NUMMIS: MATERIALGRUNDLAGEN ZU DEN IRANISCHEN PERSONENNAMEN AUF ANTIKEN MÜNZEN.** Wien, 1986. Folio, original gray cloth lettered in blue. 347, (25) pages; softcover *Tafelband* with 47 plates. Housed in cardboard slipcase. Fine. **\$250**
Infrequently offered and quite important. Daehn 6177.

Ancient Coin Societies of Canada

2 Ancient Coin Society. **CORNUCOPLÆ.** Volume I, Numbers 1–5; Volume II, Numbers 1 and 2; Volume III, Numbers 1–4, and the single-issue Volume IV. Toronto, 1972–1979. Twelve issues total, being nearly a complete set. Varying formats; near fine. [*with*] Ancient Coin Society. **NEWS SUPPLEMENT.** Thirteen issues. Toronto, 1974–1978. Stapled sheets. Near fine. [*with*] Classical and Medieval Numismatic Society. **THE ANVIL: THE BIMONTHLY/QUARTERLY PUBLICATION OF THE CLASSICAL & MEDIEVAL NUMISMATIC SOCIETY.** Volumes 1 through 10, apparently complete. Willowdale, 1991–2000. Indexes included. Volumes 4–6 are bound in one volume; the other issues are loose, as published. [*with*] Classical and Medieval Numismatic Society. **THE PICUS: THE ANNUAL JOURNAL OF THE CLASSICAL & MEDIEVAL NUMISMATIC SOCIETY.** Five volumes, for 1992–1996. Willowdale, 1993–1998. 8vo, original matching printed card covers. Cumulative Index for 1992–1996 included. Fine. [*with*] Classical and Medieval Numismatic Society. **THE JOURNAL OF THE CLASSICAL & MEDIEVAL NUMISMATIC SOCIETY.** Volumes I–VI, complete in 23 issues (Volume I had only three issues). 4to, original printed card covers. Generally fine or nearly so. **\$100**

Five publications by Canadian societies organized to promote ancient and medieval numismatic study. The Ancient Coin Society was the predecessor organization, lasting for most of the 1970s, while the Classical and Medieval Numismatic Society was active in the 1990s. Their publications can be bibliographically complex, particularly the less formal *News Supplement* of the Ancient Coin Society. Ex TAB Library.

Notable Series of Auction Catalogues

3 Auctiones A.G./S.A. [Münzen und Medaillen et al.]. **AUCTIONES S.A. SALES.** Twenty-two illustrated sale catalogues, being Numbers 3–8, 10–13, 15–18, 20, 22–27 and 29. Basel, 1973–2003. 4to, original printed card covers. Some with prices realized lists. Generally fine. **\$120**

An important series of sales. Ex TAB Library.

Forni Reprint of the Traité

4 Babelon, Ernest. **TRAITÉ DES MONNAIES GRECQUES ET ROMAINES.** Reprint. Bologna: Forni, 1965–1976. Nine volumes, complete. Tall 8vo, original matching blue cloth, gilt. 3340 pages; 355 plates. Near fine. **\$300**

The infrequently seen reprint of this foundational work. Clain-Stefaneli 1809*: “An unfinished but monumental work, indispensable for the scholar.” Grierson 52. Ex TAB Library.



de Morgan on Persian Coins

5 [Babelon, Ernest]. Morgan, Jacques de. **TRAITÉ DES MONNAIES GRECQUES ET ROMAINES. III. MONNAIES ORIENTALES. TOME I: NUMISMATIQUE DE LA PERSE ANTIQUE PAR JACQUES DE MORGAN. 1er FASCICULE: INTRODUCTION. – ARSACIDES. 2e FASCICULE: PERSIDE – ELYMAÏDE – CHARACÈNE. 3e FASCICULE: DYNASTIE SASSANIDE.** Paris, 1927–1933. Bound in two volumes. 8vo, later blue and maroon textured cloth, gilt; jackets derived from original printed paper covers. vi, (2) pages; 232 double columns; (233)–337, (1) pages; (341)–396 double columns; (397)–419 pages; (420)–465 double columns; (466)–484 pages; (485)–526 double columns; (527)–538 pages; 539–540, (2) double columns; (543)–656 double columns; (657)–738, (1) pages; (4), iii, (1) pages; 2 folding genealogical tables; text figures and tables; 78 very fine plates of coins. A typewritten letter, substantially augmented by hand, sent in 1950 from R.L. Protasowicki of B.A. Seaby, Ltd. to H.W. McBride, on the subject of Parthian coins, is laid in. Near fine. **\$900**

A well-preserved set of the final two-volume segment of the *Traité*, on ancient Persian coins, written by Jacques de Morgan. Rare and important. Clain-Stefaneli 1809*. Grierson 52. Ex Joel L. Malter Library, with his bookplates; ex TAB Library.



Rare Memorial Volume for Ernst Justus Haerberlin

6 Bahrfeldt, Max von. *ERNST JUSTUS HAEBERLIN: SEIN WIRKEN IN WISSENSCHAFT UND LEBEN*. München, 1929. Tall 4to, original gilt-printed card covers; clear original jacket; housed in original printed folder. 96 pages; fine frontispiece portrait; 4 halftone plates. Fine. **\$300**

Rarely offered and quite wonderful. Includes a biographical sketch of Haerberlin, a bibliography of his published works, and various articles by him. This copy is essentially as issued.

The Kunstfreundes Sale

7 Bank Leu, and Münzen und Medaillen. *GRIECHISCHE MÜNZEN AUS DER SAMMLUNG EINES KUNSTFREUNDES*. Zürich, 28. Mai 1974. 4to, later blue cloth, gilt; original printed card covers bound in. 372 pages; 253 lots; well illustrated throughout. Near fine. **\$100**

A bound copy of a most important sale, superbly catalogued and illustrated, comprising selections from the magnificent Charles Gillet collection. One of the great Greek coin sales of the 20th century; the 253 lots realized over \$4 million. Daehn 2026. Spring 418: "the Kunstfreund catalogue set new standards in the cataloguing of ancient coins, both as to scholarship of the content and artistic layout" [also listed under "Most important sales of ancient Greek coins"]. Ex Joel Malter Library.

Corpus Nummorum Romanorum:

The Imperial Coins

8 Banti, Alberto, and Luigi Simonetti. *CORPUS NUMMORUM ROMANORUM*. Firenze, 1972–1979. Eighteen volumes, complete. 8vo, matching original green cloth, gilt. 5680 pages; 20,346 illustrations of coins in the text. Bilingual: Italian and English. Bindings rubbed as usual; very good. **\$200**

An important work, spanning Gnaeus Pompeius Magnus to Nero. Clain-Stefanelli 4091*. Kroh 72: "perhaps the most ambitious project ever attempted for Roman coinage, its 18 volumes cover the period from Julius Caesar to Nero and utilized virtually every coin illustrated in the major auctions and published collections of 20th century Europe." Ex TAB Library.

Corpus Nummorum Romanorum:

The Republican Coins

9 Banti, Alberto. *CORPUS NUMMORUM ROMANORUM. MONETAZIONE REPUBBLICANA*. Firenze, 1980–1982. Nine volumes, complete. 8vo, original matching red cloth, gilt. 3088

pages; 12,404 illustrations of coins in the text. Bilingual: Italian and English. Bindings rubbed as usual; very good. **\$200**

An important corpus of Roman Republican coins, arranged alphabetically by moneyers. Clain-Stefanelli 3717. Ex TAB Library.

Bastien on the Arras Hoard

10 Bastien, Pierre, and Catherine Metzger. *LE TRÉSOR DE BEAURAINS (DIT D'ARRAS)*. Wetteren, 1977. 4to, original red cloth, gilt. 258 pages; illustrated throughout and on 4 plates, 2 in color with guards. Fine. **\$100**

Numismatique romaine: essais, recherches et documents, Vol. X. A less frequently encountered volume in this series. Clain-Stefanelli 4591.



Photographic Record of the Biaggi Collection

11 [Biaggi de Blasys, Leo]. *PHOTOGRAPHIC RECORD OF THE L. BIAGGI BLASYS COLLECTION OF ROMAN GOLD COINS AND MEDALLIONS*. 4to, dark blue cloth; red spine label, gilt. Bound volume of 134 leaves reproducing the photographic record of the entire collection of Leo Biaggi de Blasys, comprising some 2398 coins. Fine. **\$750**

A useful photographic record of Biaggi's astonishing collection of Roman gold coins. Important. Leo Biaggi de Blasys (1906–1979) assembled one of the greatest collections of Roman gold coins ever formed. Sold outright to Bank Leu in 1978, the coins were introduced gradually into the marketplace over a period of about thirty years. The reproduced illustrations are of rather high quality. Rarely offered.

Electrum Coinage of Phokaia and Mytilene

12 Bodenstedt, Friedrich. *DIE ELEKTRONMÜNZEN VON PHOKAIA UND MYTILENE*. First edition. Tübingen: Verlag Ernst Wasmuth, 1981. 4to, original green cloth, gilt; jacket. x, 390 pages; 63 plates. Fine. **\$100**

Essential. Daehn 4747: "A full die study of the electrum coinages of Phocaea and Mytilene. The standard reference for these coins." Ex TAB Library.

Boppearachchi's Catalogue Raisonné

13 Boppearachchi, Osmund. *MONNAIES GRÉCO-BACTRIENNES ET INDO-GRECQUES: CATALOGUE RAISONNÉ*. Paris: Bibliothèque Nationale, 1991. 4to, original printed card covers. 459, (5) pages; maps; tables; 69 plates of coins. Covers worn; very good. **\$120**

A landmark work on the subject, providing a detailed catalogue of the Baktrian and Indo-Greek coins in the Bibliothèque Nationale, as well as referencing types published elsewhere or otherwise known to the author. Daehn 6281. Ex TAB Library.

Ancient Coins of Pakistan

14 Bopearachchi, Osmund, and Aman Ur Rahman. **PRE-KUSHANA COINS IN PAKISTAN**. Karachi, 1995. 4to, original dark gray leatherette, gilt; jacket. (10), 237, (1) pages; very well illustrated in color throughout. Jacket with some wear; near fine. **\$150**

Important and hard to find. Daehn 6295: "Publishes 1090 coins with a detailed account of the history of the rulers who issued the coins."

Major Work on Indian Coins

15 Bopearachchi, Osmund, and Wilfried Pieper. **ANCIENT INDIAN COINS**. Turnhout: Brepols, 1998. 4to, later half black morocco with blue cloth sides; spine with five raised bands, ruled and lettered in gilt; blue textured endpapers; all page edges speckled blue; original pictorial front card cover bound in. (10), 289, (3) pages; text figures; maps; 59 plates of coins. Fine. **\$200** Infrequently available, and a major English-language work on the subject. Volume 2 in the *Indicopleustoi: Archaeologies of the Indian Ocean* series. Ex Alain Poinson Library.

Original BMC Greek on Corinth & Colonies

16 [British Museum]. Head, Barclay V. **CATALOGUE OF GREEK COINS. CORINTH, COLONIES OF CORINTH, ETC.** Ed. Reginald Stuart Poole. London, 1889. 8vo, later blue half calf with textured cloth sides; spine lettered in gilt; decorative endpapers. lxxviii, 174, (2) pages; 39 fine plates. Only minor signs of wear; near fine. **\$200**

A Catalogue of Greek Coins in the British Museum, Volume 12. The scarce original edition of this particularly notable volume, with superior plates. Clain-Stefanelli 1888*. Daehn 1776 & 4261: "Covers the coinage of Corinth and other cities which assimilated Corinthian coinage. Sixty-eight pages of introductory text precede the 174-page catalogue of coins." Grierson 54–55.

**Original BMC Greek on Caria & the Islands**

17 [British Museum]. Head, Barclay V. **CATALOGUE OF THE GREEK COINS OF CARIA, COS, RHODES, &C.** London: British Museum, 1897. 8vo, later blue half calf with textured cloth sides; spine lettered in gilt; decorative endpapers. cxviii, (2), 325, (3) pages; folding linen-backed color map; 45 fine plates. Only minor signs of wear; near fine. **\$150**

A Catalogue of Greek Coins in the British Museum, Volume 18. An attractive copy of the first edition of this BMC Greek volume, with plates that are far superior to those found in the reprints. Clain-Stefanelli 1888*. Daehn 1776 & 4875: "The 325-page catalogue of coins is preceded by 133 pages of introductory text." Grierson 54–55.

Original BMC Greek on Galatia, &c.

18 [British Museum]. Wroth, Warwick. **CATALOGUE OF THE GREEK COINS OF GALATIA, CAPPADOCIA, AND SYRIA**. London: British Museum, 1899. First edition. 8vo, original blue cloth, gilt. xci, (1), 341, (1) pages; folding map; 38 fine autotype plates. Professionally rebaked; original spine covering laid onto new spine. Pastedowns with removed labels; small embossed stamp throughout. Very good. **\$150**

A Catalogue of Greek Coins in the British Museum, Volume 20. The original edition, with much-superior plates. Scarce. Clain-Stefanelli 1888*. Grierson 54–55.

**First Edition BMC Roman Republican**

19 [British Museum]. Grueber, H. A. **COINS OF THE ROMAN REPUBLIC IN THE BRITISH MUSEUM**. London, 1910. First edition. Three volumes complete. 8vo, later matching maroon cloth, gilt; top page edges gilt. cxxv, (1), 594; (6), 592; (6), 236 pages; tables; text illustrations; 123 superb autotype plates of coins. Near fine. **\$400**

An unusually well-preserved first edition set. Still widely utilized and particularly valuable for historical notes. The plates in the original edition are far superior to those found in the reprint. Clain-Stefanelli 3718*. Ex TAB Library.

BMC Roman Republican Reprint

20 [British Museum]. Grueber, H.A. **COINS OF THE ROMAN REPUBLIC IN THE BRITISH MUSEUM**. Reprint. London, 1970. Three volumes. Tall 8vo, original matching red cloth, gilt. cxxv, (1), 594; (6), 592; (6), 236 pages; tables; text illustrations; 123 plates of coins. Previous owner's stamp; near fine. **\$100**

Still widely used and particularly valuable for historical notes. Clain-Stefanelli 3718*. Ex TAB Library.

Complete BMC Greek Reprint

21 [British Museum]. **A CATALOGUE OF THE GREEK COINS IN THE BRITISH MUSEUM**. Twenty-nine volumes, complete. Bologna, 1963–1965 Forni reprints. 8vo, original blue cloth, gilt. 10,688 pages; text illustrations; maps; tables; 952 plates of coins. Generally near fine. **\$1000**

The useful reprints of the most comprehensive and important standard reference work on ancient Greek coins ever published. Original sets are few and far between. These early reprints are generally held to include better plates than the later reprints. Clain-Stefanelli 1888*. Daehn 1776. Grierson 54–55. Kroh 10 (four stars): "the most utilized reference work for Greek coins ... they still remain essential references and publish a great many coins not found elsewhere." Ex TAB Library.

Search by subject, author, title or keyword
on our online store at numislit.com.

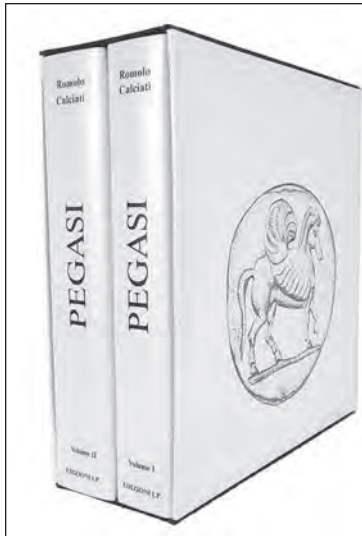

Calciati's Magnificent Pegasi

25 Calciati, Romolo. *PEGASI*. Mortara, 1990. Two volumes. Small square 4to, original matching black cloth, gilt; jackets; both volumes housed in a matching slipcase. 729, (3) pages; profusely illustrated throughout. Bilingual: English and Italian. Fine. **\$400**
A fine set of this very impressive work. Daehn 4253: "A corpus of the silver coinage of Corinth,

her colonies in Greece, Italy, and Sicily, and the independent cities which issued coins of Corinthian type. The catalogue is arranged by city and then by coin type... Catalogues 13,650 coins and includes 2855 illustrations." Kroh 38 (five stars): "a brave attempt at a corpus of the silver coinage of Corinth and all of her 26 colonies. ... The coverage is certainly comprehensive." Ex TAB Library.

BMC Celtic

22 [British Museum] Allen, Derek. *CATALOGUE OF THE CELTIC COINS IN THE BRITISH MUSEUM. VOLUME I: SILVER COINS OF THE EAST CELTS AND BALKAN PEOPLES. [with] VOLUME II: SILVER COINS OF NORTH ITALY, SOUTH AND CENTRAL FRANCE, SWITZERLAND AND SOUTH GERMANY. [with] VOLUME III: BRONZE COINS OF GAUL.* London, 1987, 1990 and 1995. Three volumes. 8vo, original matching blue boards, gilt; jackets. 80 + 71, (1) + 106, (2) pages; 31 + 29 + 38 plates of coins. Jackets a bit worn; else fine. **\$250**
All three volumes of this very important reference. Daehn 2172. Ex TAB Library.

Complete BMC Roman Imperial Reprint

23 [British Museum]. Mattingly, Harold, R.A.G. Carson and Philip V. Hill. *COINS OF THE ROMAN EMPIRE IN THE BRITISH MUSEUM. Volumes I–VI, complete.* London, 2005 reprint in six volumes. 8vo, original matching maroon cloth, gilt. ccxxxi, (1), 464; cv, (3), 485, (3); cxvii, 640; cc, 964; cclxvi, 700; cclxvi, 77, (1); viii, (2), 311, (1) pages; 504 plates of coins. A fine set. **\$400**
The indispensable standard work. The 2005 reprint used a new process for reproducing the plates from the original collotypes, resulting in continuous tone illustrations. Clain-Stefanelli 4017*. Grierson 73. Kroh 72. Ex TAB Library.

Cahn on Naxos

24 Cahn, Herbert A. *DIE MÜNZEN DER SIZILISCHEN STADT NAXOS. EIN BEITRAG ZUR KUNSTGESCHICHTE DES GRIECHISCHEN WESTENS.* First edition. Basel, 1944. 8vo, original printed card covers with mounted coin illustration. 168 pages; 12 fine plates. Spine worn; very good. **\$100**
Clain-Stefanelli 2246*: "Emphasizes economic as well as artistic aspects." Daehn 3062. Grierson 63. Kroh 20 (five stars): "an excellent die-corpus ... and still the standard reference."

Canessa's 1928 Collezione Polese

26 Canessa, Galleria. *COLLEZIONE POLESE. MONETE GRECHE E ROMANE.* Napoli, 12 Giugno 1928 e giorni seguenti. 4to, original printed card covers. (8), 61, (3) pages; 1204

lots; 16 fine plates of coins with tissue guards. Very good. **\$150**
Clain-Stefanelli 1757. Grierson 286. Spring 97 [also listed under "Most important sales of ancient Greek coins"].

Cayón's Four-Volume Compendium of Roman Coins

27 Cayón, Juan R. *COMPENDIO DE LAS MONEDAS DEL IMPERIO ROMANO. VOLUMEN I–VOLUMEN IV: DE POMPEYO EL GRANDE (81 A.C.) A ANASTASIO (491 D.C.).* Madrid, 1990–1995. Four volumes, complete. 4to, original matching tan leatherette, lettered and decorated in brown. xxxi, (1), 780, (14); xvi, 781–1489, (15); ix, (1), 1491–2390, (6); ix, (1), 2391–3255, (7) pages; numerous text illustrations of coins throughout; valuations. Near fine. **\$120**
Kroh 70: "a handbook of types with valuations."

Near Complete Celator

28 *THE CELATOR.* Volumes 4–26 (Lodi and Lancaster, 1990–2012), complete for the period covered. 4to, original printed pictorial paper covers [issues through Volume IV, Number 8 were published in tabloid format]. Volume 26 is truncated, as issued, with the periodical ceasing publication after Number 5. The *Best of the Celator* compilation for 1988 is also included. Fine. **\$300**
A nearly complete set of *The Celator* in magazine form (the first three volumes and the first eight issues of the fourth volume were published in tabloid form). A remarkable numismatic publication, truly missed, and simply indispensable to anyone actively involved in ancient numismatics. Ex TAB Library.

Works on Alexandrian Coins

29 Christiansen, Erik. *COINS OF ALEXANDRIA AND THE NOMES. A SUPPLEMENT TO THE BRITISH MUSEUM CATALOGUE.* London: British Museum, 1991. 4to, original printed card covers. vii, (1), 151, (1) pages; 12 plates of coins. Bumped; near fine. [with] Emmett, Keith. *ALEXANDRIAN COINS.* Lodi: Clio's Cabinet, 2001. 4to, original blue cloth, gilt. xxvi, (2), 332 pages; illustrated. Fine. **\$100**
Two modern works on the subject, with the first being an essential supplement to the BMC Greek catalogue on Alexandria. Ex TAB Library.



The Treasure of Via Alesandrina

30 Cimino, Guido, Michele Baranowsky and Guido Bezzi. *R. TRIBUNALE DI ROMA. SEZIONE PRIMA. PERIZIA DEL COLLEGIO PERITALE NOMINATO DAL TRIBUNALE DI ROMA - SEZIONE PRIMA - CON SENTENZA DEL 14 MAGGIO-12 GIUGNO 1940-XVIII PER LA STIMA DEL "TESORO DI VIA ALESSANDRINA" IN ROMA.* Perugia, 1942. 4to, original printed card covers. xxxi, (1), 202 pages; 7 superb mounted photographs depicting ancient Greek, Roman and Byzantine coins, Italian coins, engraved gems and jewelry. Front cover stained along edge of spine; minor chips to cover; near fine, overall. **\$750**

An extremely rare catalogue, and an important photographic record. It is one of only a few examples we have encountered in four decades. The text features an *Elenco delle Opere Fondamentali*; a description of coin grading; a listing of important European auction sale catalogues featuring ancient Greek, Roman, Italian, Papal and other coins; followed by a catalogue of over 2600 items, with printed values exceeding 1.2 million lire. The last copy we handled was the one in the Kreindler Library, which brought \$1100 hammer in 2014.

Coin Hoards from Roman Britain

31 [Coin Hoards from Roman Britain]. Bland, Roger, and Andrew Burnett [editors]. *THE NORMANBY HOARD AND OTHER ROMAN COIN HOARDS.* London, 1988. 4to, original red boards, gilt; jacket. 238, (2) pages; 40 plates of coins. Fine. [with] Bland, Roger [editor]. *THE CHALFONT HOARD AND OTHER ROMAN COIN HOARDS.* London, 1992. 4to, original green boards, gilt; jacket. 366, (2) pages; 32 plates of coins. Fine. [with] Bland, Roger, and John Orna-Ornstein [editors]. *COIN HOARDS FROM ROMAN BRITAIN. VOLUME X.* London: British Museum, 1997. 4to, original black boards, gilt; jacket. 479, (1) pages; 48 plates of coins. Fine. [with] Abdy, Richard, et al. [editors]. *COIN HOARDS FROM ROMAN BRITAIN. VOLUME XI.* London: Royal Numismatic Society, 2002. 4to, original red boards, gilt; jacket. 233, (1) pages; 10 plates of coins. Fine. **\$150**

Volumes 8–11 of the *Coin Hoards from Roman Britain* series. Volume 10 presents information on 57 coin hoards, most of them discovered since the mid-1980s. Volume XI covers hoards discovered between 1997 and 2001, including the Shapwick Villa (Somerset) hoard of 9000+ denarii. Ex TAB Library.

Indexes of the Revue Numismatique

32 Dieudonné, A. *TABLE DE LA REVUE NUMISMATIQUE (DE 1835 À 1905).* Paris, 1908. 8vo, original printed paper covers. xi, (1), 260 pages. [with] *TABLE DE LA REVUE NUMISMATIQUE (DE 1906 À 1915).* Paris, 1919. 8vo, original printed paper covers. 124 unopened pages. Fine. **\$100**

At the time of publication, these indexes covered the entirety of the eighty-year run of the *Revue numismatique*, and provided researchers with an exceptionally useful resource for making full use of what remains one of the greatest numismatic journals.

Clain-Stefanelli Festschrift

33 Doty, Richard G., et al. [editors]. *ITALIAM FATO PROFUGI HESPERINAQUE VENERUNT LITORA: NUMISMATIC STUDIES DEDICATED TO VLADIMIR AND ELVIRA ELIZA CLAIN-STEFANELLI.* Louvain-La-Neuve, 1996. 4to, original green cloth, gilt. xxiii, (1), 366 pages; numerous text illustrations. Fine. **\$120**

Numismatica Lovaniensia 12. Remarkably difficult to find. Featured is a curriculum vitae and bibliography of the Clain-Stefanellis, followed by Elvira's autobiography, which chronicles the lives of both honorees. Includes articles by Michel Amandry, Carmen Arnold-Biucchi, Pierre Bastien, Christof Boehringer and others.

Draganov on Macedonia

34 Draganov, Dimitar. *THE COINS OF THE MACEDONIAN KINGS, PART I: FROM ALEXANDER I TO ALEXANDER THE GREAT. PART II: FROM PHILIP ARRHIDAEUS TO PERSEUS / МОНЕТИТЕ НА МАКЕДОНСКИТЕ ЦАРЕ, ЧАСТ I: ОТ АЛЕКСАНДЪР I ДО АЛЕКСАНДЪР ВЕЛУКУ. ЧАСТ II: ОТ ФИЛИП III АРИДЕЙ ДО ПЕРСЕЙ.* Jambol, 2000 and 2001. Two volumes, complete. 8vo, original pictorial boards. 220 + 224 pages; illustrated. In Bulgarian. Fine. **\$100**
A useful and well-illustrated reference.

Florange & Ciani Catalogues

35 Florange, Jules, and Louis Ciani. *COLLECTION BARRACHIN. ANTIQUITÉS. MONNAIES GRECQUES, ROMAINES, FRANÇAISES, ÉTRANGÈRES.* Paris, 18–20 décembre 1924. Crown 4to, original printed card covers. 60 pages; 785 lots; 6 fine plates of antiquities; 8 fine plates of ancient coins; 8 fine plates of French and European coins. Tear to spine covering at tail; near fine. [with] Florange, Jules, and Louis Ciani. *COLLECTION DE MÉDAILLES, MONNAIES ET ANTIQUITÉS.* Paris, 3 juillet 1925. Small 4to, original printed card covers. 8 pages; 99 lots; 1 fine plate. Fine. **\$100**

The Barrachin sale was a particularly significant offering from this notable partnership. Clain-Stefanelli 1694. Grierson 279. Spring 184.

The Allotte de la Fuyé Sales

36 Florange, Jules, and Louis Ciani. *MONNAIES GRECQUES. PROVENANT DES COLLECTIONS DU COLONEL ALLOTTE DE LA FUÏE.* Paris, 17–21 février 1925. Crown 4to, original printed card covers. 110 pages; 1842 lots; 31 fine plates. Very good or better. [with] Florange, Jules, and Louis Ciani. *MONNAIES ROMAINES, CONSULAIRES & IMPÉRIALES, MONNAIES BYZANTINES. PROVENANT DES COLLEC-*

TIONS DU COLONEL ALLOTTE DE LA FUÏE. DEUXIÈME VENTE. Paris, 28–29 avril 1925. Crown 4to, original printed card covers. 36 pages; 597 lots; 12 fine plates of Roman coins. Covers sunned and a bit worn. Very good or better. **\$120**

An important collection. Grierson 279. Spring 185 and 186 (stating that the date of the second sale was changed to 5–6 mai 1925) [first sale listed under Spring's "Most important sales of ancient Greek coins"]. Ex TAB Library.

The Ernst Justus Haebler Library

37 Fock, Gustav. NUMISMATIK BÜCHER, ABHANDLUNGEN, ZEITSCHRIFTEN, U. A. AUS DEM BESITZ DES † JUSTIZRATS DR. JUR. E.I. HAEBERLIN, FRANKFURT A. M. Leipzig: Nr. 714, 1937. 12mo, original printed paper covers. 135, (1) pages; 3495 priced listings. Front cover spotted, with some markings; else near fine. **\$100**

Ernst Justus Haebler (1847–1925) formed an extraordinary collection of the early cast coinages of the Roman Republic, and his 1910 *Aes Grave* was the result of a life's work in numismatics. Kolbe 702 ("An interesting and important library, particularly rich in works on ancient numismatics").

The Weber Greek Coins

38 Forrer, L. DESCRIPTIVE CATALOGUE OF THE COLLECTION OF GREEK COINS FORMED BY SIR HERMANN WEBER. New York, 1975 reprint. Reprint. Three volumes, complete. Crown 4to, original matching maroon cloth, gilt. 1976 pages; 317 plates. Near fine. **\$120**

The useful reprint of this magnificent collection. Ex TAB Library.

Freeman & Sear Catalogues

39 Freeman & Sear. MAIL BID SALES. Group of 17 sale catalogues, numbered 1–17, complete, 1995–2009. 4to, original printed card covers. Fine. [with] Freeman & Sear. MANHATTAN SALES. Sales 1–4, complete, 2010–2013. 4to, original printed card covers. Fine. [with] Freeman & Sear. FIXED PRICE LISTS. Lists 1–14, plus Mini List A, complete, 1994–2009. Varying formats, original printed card covers or self-covered as issued. Generally fine. **\$120**

Includes some notable catalogues. Ex TAB Library.

Important Monographs on Greek & Roman Coins

40 Fritze, Hans von, and Hugo Gaebler [editors]. NOMISMA. UNTERSUCHUNGEN AUF DEM GEBIETE DER ANTIKEN MÜNZKUNDE. 2002 Forni reprint in two volumes. 4to, original pictorial card covers. Several hundred pages; numerous folding plates. Fine. **\$100**

An infrequently seen reprint of this most important series of groundbreaking monographs on ancient (mostly Greek) coins. The plate quality is above average. Clain-Stefanelli 744. Ex TAB Library.

Indo-Scythian & Indo-Parthian Coins

41 Fröhlich, Christine. MONNAIES INDO-SCYTHES ET INDO-PARTHES. CATALOGUE RAISONNÉ. Paris: Bibliothèque Nationale, 2008. 4to, original pictorial card covers. 158 pages; 29 plates. Fine. **\$100**

A highly significant catalogue of the collection of these coins in the Cabinet des médailles. Ex TAB Library.

Apollinaires, célébrés depuis la seconde guerre punique, et pendant plusieurs jours consécutifs, du 6 au 13 juillet de chaque année. Après son frère, c'est Diane lucifère qui réclame un instant notre attention



née de deux flambeaux, le croissant au front, elle traverse les ténèbres; elle illumine. Sa longue tunique et son manteau flottant au gré du vent

Classic Treatise on Roman Medallions

42 Frøehner, W. NUMISMATIQUE ANTIQUE. LES MÉDAILLONS DE L'EMPIRE ROMAIN DEPUIS LE RÈGNE D'AUGUSTE JUSQU'À PRISCUS ATTALE. Paris: J. Rothschild, 1878. 4to, original printed paper covers. xiv, 396 pages; title printed in three colors; numerous text illustrations of coins. Paper spine a little weak; occasional light spotting. Near fine. **\$400**

The classic work, and one of the first to treat the subject of Roman medallions in any comprehensive manner. Scarce, especially when well-preserved. Clain-Stefanelli 4962.

Scarce Original Folio Edition

43 Gardner, Percy. THE TYPES OF GREEK COINS. AN ARCHAEOLOGICAL ESSAY. Cambridge: At the University Press, 1883. Folio, original green cloth, top cover impressed with gilt depiction of dekadrachm of Akragas; top page edges gilt. viii, 217, (3) pages; 16 very fine autotype plates of coins with text. Near fine. **\$150**

A well-preserved copy of this superbly illustrated classic work. Clain-Stefanelli 3442. Grierson 59.

Gemini Ancient Coin Sales

44 Gemini Numismatic Auctions. AUCTION CATALOGUES. Twelve sale catalogues, being Numbers 1–12. New York, 2005–2015. All 4to, original pictorial card covers; illustrated. A few with prices realized lists. Generally fine. **\$100**

Notable catalogues of ancient and world coins, at first produced by Harlan J. Berk and Freeman & Sear and held at the New York International Numismatic Convention, and later involving other firms including B. & H. Kreindler, Amphora, and Heritage. Ex TAB Library.

Roman Coins in the Bibliothèque Nationale

45 Giard, Jean-Baptiste. CATALOGUE DES MONNAIES DE L'EMPIRE ROMAIN. I: AUGUSTE. II: DE TIBÈRE À NÉRON. III: DU SOULÈVEMENT DE 68 APRÈS J.-C. À NERVA. Paris: Bibliothèque Nationale, 1976, 1988 and 1998. Three volumes. 4to, original matching green leatherette, gilt; last with jacket, as issued. viii, 258, (2) + (6), 181, (3) + ix, (1), 366 pages; hundreds of coin plates; color enlargements. Near fine or better. **\$200**

An important museum catalogue by the late curator of the French cabinet. Kroh 72 (five stars). Ex TAB Library.

Gorny & Mosch Ancient Coin Catalogues

46 Giessener Münzhandlung / Gorny & Mosch. AUCTION CATALOGUES. One hundred ten sales, being Numbers 33, 36, 38, 40, 42, 44, 46, 48, 50, 52, 55–56, 58, 60, 62, 64, 66–67, 69, 71, 73, 75–76, 78–79, 81–82, 84, 87, 89–90, 92, 95–97, 100 (two catalogues), 101–102, 104, 107–108, 112–115, 117–118, 121–122, 125–126, 129–130, 133–134, 138, 141–142, 146–147, 151–152, 155–156, 159–160, 164–165, 169–170, 175–176, 180–181, 185–186, 190–191, 195–196, 199–200, 203–204, 207–208, 211–212, 215–216, 219–220, 224–225, 228–229, 232–233, 236–237, 240–241, 244–245, 249, 253, 257, 261 and 265. München, 1986–2019. All 4to, original pictorial card covers; illustrated [Sales 38–48 are bound together in one volume]. A number with prices realized lists. Generally fine. **\$300**

Well-produced catalogues, all of which include ancient coins. Ex TAB Library.



Photographic Record of the Gillet Collection

47 [Gillet, Charles]. PHOTOGRAPHIC RECORD OF THE CHARLES GILLET COLLECTION. 4to, dark blue cloth; red spine label, gilt. Bound volume of 58 leaves reproducing the photographic record of the entire collection of Charles Gillet, comprising some 1217 coins. Fine. **\$750**

An important record of this collection, 253 highlights of which were sold in 1974 by Bank Leu and Münzen und Medaillen as the Kunstfreundes collection. One of the most important collections of ancient Greek coins to be sold in the 20th century. The reproduced illustrations are of good quality.

Gnecchi on Roman Medallions

48 Gnecchi, Francesco. I MEDAGLIONI ROMANI. Bologna: Forni, 1968 reprint. Three volumes, complete [plates bound with relevant text volumes]. Tall 4to, original mustard cloth, gilt. Frontispiece; lxviii, 83, (5); (16), 158, (6); (16), 234, (6) pages; 162 plates. Near fine. **\$120**

The standard work. Originals are rarely encountered. Clain-Stefanelli 4963*. Grierson 84.

1618 Edition of Goltzius's Thesaurus Rei Antiquariae

49 Goltzius, Hubertus. THESAURUS REI ANTIQUARLÆ HUBERRIMUS EX ANTIQUIS TAM NUMISMATUM QUAM MARMORUM INSCRIPTIONIBUS PARI DILIGENTIA QUAM FIDE CONQUISITUS AC DESCRIPTUS, & IN LOCOS COMMUNES DISTRIBUTUS, PER HUBERTUM GOLTZIUM

HERBIPOLITAM VENLONIANUM CIVEM ROMANUM. Antverpia: Apud Gulielmum à Tongris, 1618. Small folio [28 by 20 cm], modern cream cloth and boards, lettered in black. Title with woodcut printer's device; 84 leaves irregularly numbered as: (8) pages + 314 columns + 1 page; woodcut initials. Text uniformly browned. Binding worn; very good. **\$250**

The separately printed 1618 edition of the second part of the earliest substantial work to organize the documentation for the early *fasti* of Rome, using coins and monuments as the source material. Christian Dekesel (*Hubert Goltzius: The Father of Ancient Numismatics*, 1988) notes that Goltzius "was granted an official Roman citizenship on May 7th 1567" for this work on Roman feasts. Hubert Goltz (1526–1583) published his first book, *Icones imperatorum*, in 1557 at the age of 21. He subsequently traveled through Germany, France and Italy, examining collections of antiquities to advance his research. Upon his return to Bruges in 1560, he sought to publish the great wealth of material he had accumulated. Accordingly, he set up a printing press in his home and supervised the execution of the numerous prints that were to accompany his works, often engraving the plates himself. Dekesel writes that "The influence of Hubertus Goltzius upon numismatics is mostly underestimated. One forgets very easily that he was the first author who wrote and published a comprehensive view upon the coinage of the Ancients and that he was also the first to do that on the basis of a real contact with some of the great coin cabinets of the civilized Renaissance world." Ferdinando Bassoli notes that "the writers and illustrators of the following two centuries would not have been able to do without him" (*Antiquarian Books on Coins and Medals*, 16), and Ernest Babelon agreed, saying that "Hubert Goltz contributed more than any of his contemporaries to the spread of interest in numismatics. His work on the classification and attribution of coins was vital in laying the foundation for a sound critical analysis" (*Ancient Numismatics and Its History*, 75). Banduri (1718) 12 & 27. Brückmann 49. Dekesel G88. Hirsch (1760) 49. Labbé (1675) 12. Lipsius 152. Struve 83 (1644 edition).

The McClean Collection Reprint

50 Grose, S.W. CATALOGUE OF THE MCCLEAN COLLECTION OF GREEK COINS. Reprint. Chicago, 1979. Three volumes. Small quarto, original matching red cloth, gilt. x, (2), 380 + (6), 563, (1) + vi, 507, (1) pages; 380 plates. Fine. **\$100**
A great collection, well catalogued and finely illustrated, now in the Fitzwilliam Museum. Clain-Stefanelli 1887*. Grierson 57. Ex TAB Library.

Major Work on Ancient Brooches

51 Hattatt, Richard. ANCIENT AND ROMANO-BRITISH BROOCHES. Dorset: Dorset Publishing Company, 1982. 8vo, original brown cloth, gilt; jacket. 224 pages; illustrated. Jacket a bit sunned; near fine. **\$120**

One of the more frequently cited references on the subject.

An Annotated First Edition

52 Head, Barclay V. HISTORIA NUMORUM: A MANUAL OF GREEK NUMISMATICS. Oxford: At the Clarendon Press, 1887. First edition. 4to, original brown quarter morocco, gilt; top page edges gilt. lxxix, (1), 807, (1) pages; 400 text illustrations; tables; 5 plates. Annotated throughout in pencil, often recording prices realized at the 1921 Pozzi sale. Spine a little rubbed; near fine. **\$100**
A superior copy of the first edition of this landmark work. Though revised editions of numismatic books are usually preferred, sometimes it pays to consult the earlier editions. In the revised and enlarged 1911 edition of *Historia Numorum*, the author himself allowed that "(i)t is

possible that, among those who are familiar only in a general way with the old edition of this work, there may be some who, on comparing with it the present revised edition, will, at first sight, be inclined to think that some portions of what has been omitted were of greater interest than what has been added." A 1927 Spink catalogue emphasized that aspect of the 1887 work: "Some portions of the first edition of very great interest were omitted from the second, and this fact added to the usefulness of the work in itself makes a copy of that edition well worth acquiring especially by the young collector." Clain-Stefanelli 1832*, citing the second edition. Daehn 90.

1920s Helbing Sales

53 Helbing, Otto (Nachf.). SAMMLUNG † HOFRAT HERMANN ETC. GRIECHISCHE MÜNZEN UND RÖMISCHE MÜNZEN. München, 24. Oktober 1927 und folgende Tage. 4to, later maroon cloth, gilt; original printed card covers bound in within archival sleeves. (8), 255, (1) pages; 3890 lots; 80 fine plates. Minor repairs; very good or better. [with] Helbing, Otto (Nachf.). BEDEUTENDE SAMMLUNG VON MÜNZEN UND MEDAILLEN DER GEFÜRSTETEN GRAFSCHAFT TIROL DES INGENIEURS FRANZ SEIF. SAMMLUNG GEHEIMRAT VON K. FRANZÖSISCHE REVOLUTION UND NAPOLEON. MÜNZEN UND MEDAILLEN VON BADEN. München, 5. November 1928. 4to, original printed card covers. (8), 215, (1) pages; 3160 lots; 44 fine plates; valuation list. Housed in custom-made clamshell box. Very good. **\$100**

Two auction catalogues from this notable if underappreciated Munich firm. While the Helbing firm traces its roots to 1878, most of the auction catalogues issued under the name of Otto Helbing post-date his retirement in 1912; the firm was run in later years by Heinrich Hirsch, Willy Schwabacher and Gerhard Hirsch until the Nazi era, during which management was assumed by Karl Kreß. The first sale is Clain-Stefanelli 9225. Spring 295 [also listed under "Most important sales of ancient Greek coins" and "Most important sales of Roman Imperial coins"]. The second sale is Clain-Stefanelli 8291. Ex Richard E. Margolis Library.

The Hellenic Numismatic Society's Chronika

54 Hellenic Numismatic Society. ΝΟΜΙΣΜΑΤΙΚΑ ΧΡΟΝΙΚΑ. A largely complete set of twenty-six issues, being Nos. 1–28 (of 32 published) except for Nos. 2 and 8. Athens, 1972–2010. 8vo, original pictorial card covers. Generally near fine. **\$120**
An important journal, with articles in Greek and English. Clain-Stefanelli 747. Ex TAB Library.

Magnificent Enlarged Plates of Greek Coins

55 Hill, George F. SELECT GREEK COINS: A SERIES OF ENLARGEMENTS, ILLUSTRATED AND DESCRIBED. First edition. Paris and Brussels, 1927. Folio, somewhat later brown quarter morocco, gilt. 61, (3) pages; 64 fine plates. Ex Cheltenham Public Library, with their bookplate and small ink-stamps throughout. Very good or so. **\$100**
A major work, being a superb series of enlarged illustrations of artistic Greek coins. The oversized format has resulted in most surviving copies having various binding problems. Clain-Stefanelli 3557. Daehn 1168.



1882 Bompois Sale, with Exceptional Plates

56 Hoffmann, H. COLLECTION FERDINAND BOMPOIS. MÉDAILLES GRECQUES AUTONOMES. LIVRES DE NUMISMATIQUE ET D'ARCHÉOLOGIE. Paris: Maurice Delestre, 16–21 janvier 1882. 8vo, contemporary brown quarter morocco with mottled paper sides; spine with five raised bands, lettered in gilt; marbled endpapers; original printed paper covers bound in. vii, (1), 200 pages; 2155 + 223 lots; 6 plates of ancient coins engraved by L. Dardel. All but the final book section priced in ink. Some spotting to plates; binding a bit rubbed and worn, but sound; front free endpaper detached. Very good. **\$120**

The very scarce catalogue of an important collection, including a Syracusan dekadrachm and a Demareteion. The engraved plates are particularly well-rendered. Spring quotes Baron de Witte, who wrote that they are "engraved with the greatest of care by Monsieur Léon Dardel, whose talent is known and appreciated by all numismatists." Babelon 226. Clain-Stefanelli 1947. Spring 389 (one of the few catalogues listed by Spring without photographically printed plates).

Holloway on Hieronymos of Syracuse

57 Holloway, R. Ross. THE THIRTEEN-MONTHS COINAGE OF HIERONYMOS OF SYRACUSE. Berlin: Deutsches Archäologisches Institut, 1969. 4to, original green cloth, gilt. xxiii, 47, (1) pages; 12 fine plates of coins. Fine. **\$120**
Infrequently offered. *Antike Münzen und geschnittene Steine*, Band III. Clain-Stefanelli 2265. Daehn 3159: "Examines the Syracusan coins of 215–214 B.C." Ex TAB Library.

Essays on the Alexander Medallion

58 Holt, Frank, and Osmund Boppearachchi. THE ALEXANDER MEDALLION: EXPLORING THE ORIGINS OF A UNIQUE ARTIFACT. Rouqueyroux: Imago Lattara, 2011. 4to, original ten cloth lettered in white and brown; mounted illustrations. 103, (1) pages; illustrated throughout in color. Fine. **\$100**
A fascinating volume devoted to this controversial piece. Based on presentations given at the École Normale Supérieure in 2007.

The Berlin Corpus Reprint

59 Imhoof-Blumer, F. [editor]. DIE ANTIKEN MÜNZEN NORD-GRIECHENLANDS... Bologna: Forni, 1977 reprint. Four volumes as published in five, complete. Tall 4to, original matching blue cloth, gilt. 1954 pages; 84 plates. Fine. **\$150**
Best described in Clain-Stefanelli's *Numismatics—An Ancient Science* (pages 42–43): "Inspired by Theodor Mommsen's idea of creating an extensive work on Greek coins as a companion to the 'Corpus of Latin Inscriptions,' the Prussian Academy of Sciences in Berlin assigned to Imhoof-Blumer the direction of *Die antiken Münzen Nord-Griechen-*

All lots illustrated in full color at
bid.numislit.com

lands. Such a corpus was intended to supersede all publications on the subject by describing every known coin type of each city or province within a chronological sequence, with full attention given to all available source material. This dream of a corpus of all ancient Greek coins seems to have haunted numismatists since the early 16th century, when Wolfgang Lazius first proposed such a work." Clain-Stefanelli 1806*, 2305*, 2368*, 2417*, 2418* and 2678. Daehn 3247, 3614, 3620 and 3621. Ex TAB Library.

Jameson Collection Reprint

60 Jameson, R. COLLECTION R. JAMESON. MONNAIES GRECQUES ANTIQUES ET MONNAIES IMPÉRIALES ROMAINES. Reprint. Chicago, 1980. Four volumes. 4to, original matching red leatherette, gilt. 908 pages; 164 plates. Fine. **\$120**
The modern reprint of this magnificent collection, of the utmost importance. Ex TAB Library.

Original Set of Jenkins on Gela

61 Jenkins, G. Kenneth. THE COINAGE OF GELA. First edition. Berlin: Deutsches Archäologisches Institut, 1970. Two volumes. 4to, original green cloth, gilt, with matching plate folder. xxiv, 312 pages, text figures, maps; 16 pages, 56 fine plates of coins. Spines sunned; near fine. **\$400**
Antike Münzen und geschnittene Steine, Band II. Clain-Stefanelli 2224*. Daehn 3010: "A comprehensive study of the coinage of Gela." Kroh 19 (five stars): "Absolutely essential, the English text is very clear and informative, the plates excellent." Ex Kolbe & Fanning Sale 153, lot 58; ex TAB Library.

Important Work on Kushan Coins

62 Jongeward, David, and Joe Cribb, with Peter Donovan. KUSHAN, KUSHANO-SASANIAN, AND KIDARITE COINS: A CATALOGUE OF COINS FROM THE AMERICAN NUMISMATIC SOCIETY. New York: ANS, 2015. First edition. Tall 4to, original tan cloth, gilt; jacket. (10), 322 pages; color text illustrations; 79 color plates. Fine. **\$100**
A highly important catalogue of these fascinating ancient coins, bringing together the latest research with color illustrations of the holdings of the American Numismatic Society. Ex TAB Library.

Foundational Study of Deultum

63 Jurukova, Jordanka. DIE MÜNZPRÄGUNG VON DEULTUM. Berlin, 1973. Two volumes, *textband und tafelband*. 4to, original matching linen and printed boards. v, (1), 169, (1) pages; map; 32 fine plates. Previous owner's bookplates. Fine. **\$100**
The only major work on the subject until Draganov's 2007 study. Part of the *Griechisches Münzwerk* series, which continued the work of *Die antiken Münzen Nordgriechenlands* project. *Schriften zur Geschichte und Kultur der Antike*, 8. Scarce. Daehn 3705 (under Youroukova). Ex Alex Malloy Library.

History of Scales & Weights

64 Kisch, Bruno. SCALES AND WEIGHTS: A HISTORICAL OUTLINE. New Haven: Yale University Press, 1965. 8vo, original brown cloth, gilt; jacket. xxi, (3), 297, (1) pages; well illustrated. Near fine. **\$100**
The best survey of the history of weighing and its instruments from ancient to modern times. Clain-Stefanelli 16039.

Roman Provincial Coins of Smyrna

65 Klose, Dietrich O.A. DIE MÜNZPRÄGUNG VON SMYRNA IN DER RÖMISCHEN KAISERZEIT. Berlin: Deutsches Archäologisches Institut, 1987. 4to, original green cloth, gilt. xxiv, 358, (2) pages; 63 plates. Fine. **\$100**
A detailed and well-illustrated catalogue. *Antike Münzen und geschnittene Steine*, Band X.

Roman Coins of Nicopolis ad Mestum

66 Komnick, Holger. DIE MÜNZPRÄGUNG VON NICOPOLIS AD MESTUM. Berlin: Akademie Verlag, 2003. 4to, original printed yellow cloth. viii, 91, (1) pages; 8 plates; charts. Fine. **\$100**
A recent contribution to the *Griechisches Münzwerk* series, which continued the work of *Die antiken Münzen Nordgriechenlands* project.

With Magnificent Enlarged Photos of Greek Coins

67 Kraay, Colin M., and Max Hirmer. GREEK COINS. New York: Harry N. Abrams, 1966. 4to, original tan linen, gilt; jacket. 396 pages; 4 maps; 20 most attractive plates of tipped-in enlarged illustrations of coins in full color; 1329 additional fine coin illustrations. Binding worn, and cracked at rear hinge; endpapers spotted. Very good or so. **\$200**
An somewhat worn copy of this important and popular book, easily restorable by a binder. Clain-Stefanelli 1849*. Daehn 127: "Noted for the 1329 photographs of 809 of the best specimens of Greek coinage." Grierson 53. Kroh 7 (5 stars): "certainly the finest work on Greek coins ever printed. It is massive in size, and contains many fantastic enlargements of the best Greek coins you are ever likely to see. The text (by Colin Kraay) is very well written, and the photography (by Max Hirmer) is truly incredible, even by today's standards. Long out of print, this is arguably the world's most sought after numismatic book."

Kraay's Classic on Early Greek Coins

68 Kraay, Colin M. ARCHAIC AND CLASSICAL GREEK COINS. First edition. Berkeley, 1976. 8vo, original green cloth, gilt. xxvi, 390 pages; maps; 64 fine plates of coins. Previous owner's signature; near fine. **\$100**
Clain-Stefanelli 1848. Daehn 124: "A comprehensive survey of Greek coinage from its beginnings down to ca. 300 B.C. illustrated by over 1100 coins." Kroh 7: "an exceptionally well done work whose depth and grasp certainly supersedes any other general work that exists for the period."

Kraft on Roman Asia Minor

69 Kraft, Konrad. DAS SYSTEM DER KAISERZEITLICHEN MÜNZPRÄGUNG IN KLEINASIEN. MATERIALIEN UND ENTWÜRFE. Berlin: Mann, 1972. 4to, original linen folder lettered in brown; text in original card covers, plates loose as issued. 220, (2) pages; 24 plates of maps; 117 plates of coins. Fine. **\$150**
Istanbuler Forschungen, Band 29. An impressive work. Clain-Stefanelli 4514*. Kroh 64 (five stars): "This is an incredible study that traces the sharing of obverse dies between various cities in Asia Minor coming to the conclusion that there were central workshops that engraved and struck coins for various cities instead of individual mints in each. ... The plates are so crisp and clear that each detail on even the most heavily worn coins stands out boldly. This is a most spectacular work that can ably serve as a basis for further study." Ex TAB Library.

Lacam's Important Work on Late Roman Coins

70 Lacam, Guy. *LA FIN DE L'EMPIRE ROMAIN ET LE MONNAYAGE OR EN ITALIE, 455-493*. Luzern, 1983. Two volumes. Folio, original matching crimson boards, gilt. Color frontispiece; 1107, (5) pages; text figures; tables; 226 + 60 fine plates of coins, including many enlargements. Fine. **\$100**

A highly important work. Kroh 91: "a truly remarkable corpus-catalogue of the gold coinage of the Italian mints of the Western Roman Empire with many surprising conclusions." Ex TAB Library.



Portrait Coins of Antiquity

71 Lange, Kurt. *HERRSCHERKÖPFE DES ALTERTUMS IM MÜNZBILD IHRER ZEIT*. Berlin & Zürich: Atlantis-Verlag, 1938. Small 4to, original black cloth, gilt; jacket. 161, (1) pages; superb enlarged illustrations throughout of ancient portrait coins. Jacket a little worn; near fine. **\$100**

A scarce title by this outstanding German photographer, less frequently encountered than most of his later works. The quality of the illustrations is exceptional. Lange (1898-1959) was an art historian and photographer who published a number of works that are primarily collections of enlarged photographs, usually with minimal text. They were intended to develop a wider appreciation for the aesthetic qualities of coins. This appears to be the first book-length work highlighting his outstanding coin photography. Clain-Stefanelli 3533. Daehn 1268.

Two Rare Offprints on Greek Coins

72 Lederer, Philipp. *EINIGE UNEDIERTE ANTIKE MÜNZEN*. Berlin: *Sonder-Abdruck aus Berliner Münzblätter*, 1919. 8vo, plain card covers with handwritten title. 6, (2) pages; 1 fine plate depicting ancient Greek and Roman coins. Near fine. [with] Imhoof-Blumer, F. *GRIECHISCHE MÜNZEN IN DER GROSSHERZOGLICH BADISCHEN SAMMLUNG IN KARLSRUHE*. Berlin: *Separatabdruck aus Band VII der Zeitschrift für Numismatik*, 1879. 8vo, original printed paper covers. 32 pages; 1 fine plate depicting ancient Greek coins. Very good or better. **\$100**

Two rare offprints from publications that are infrequently encountered, both of them with a fine colotype plate depicting ancient coins.

Lexicon of Greek Coins

73 Leschhorn, Wolfgang. *LEXIKON DER AUFSCHRIFTEN AUF GRIECHISCHEN MÜNZEN / LEXICON OF GREEK*

COIN INSCRIPTIONS. VOLUMES I-II. Wien: Österreichischen Akademie der Wissenschaften, 2002 and 2009. 4to, original matching printed boards. 426; 1092 pages. Fine. **\$150**

A massive and important publication. Daehn 1336 (Volume I).

Recent Leu Numismatik Sales

74 Leu Numismatik. *AUCTION CATALOGUES*. Zürich, 2018-2019. Four well-illustrated catalogues, being sales 2-5. 4to, original matching blue cloth lettered in silver; jackets. Fine. **\$100**

A remarkable series of recent auction catalogues, primarily of ancient and medieval coins, issued in cloth bindings and with high production values. Ex TAB Library.

Iconographic & Numismatic Study of Diocletian

75 Lukanc, Ivo. *DIOCLETIANUS: DER RÖMISCHE KAISER AUS DALMATIEN*. Wetteren, 1991. 4to, original red cloth, gilt. 343, (3) pages; well-illustrated. Fine. **\$100**

Important and rarely offered.

Imitations of Alexander

76 Lukanc, Ivo. *LES IMITATIONS DES MONNAIES D'ALEXANDRE LE GRAND ET DE THASOS*. Wetteren: Edit Cultura, 1996. 4to, original red cloth, gilt. (4), 128 pages; 174 plates. Fine. **\$100**

On Thracian imitations. Daehn 2582. Ex TAB Library.

The Hunterian Collection

77 Macdonald, George. *CATALOGUE OF GREEK COINS IN THE HUNTERIAN COLLECTION, UNIVERSITY OF GLASGOW. VOLUME I: ITALY, SICILY, MACEDON, THRACE, AND THESSALY. VOLUME II: NORTH WESTERN GREECE, CENTRAL GREECE, SOUTHERN GREECE, AND ASIA MINOR. VOLUME III: FURTHER ASIA, NORTHERN AFRICA, WESTERN EUROPE*. Bologna: Forni, 1975 reprint. Three volumes, complete. Tall 4to, original matching ochre cloth, gilt. 2040 pages; tables; 102 plates of coins. A fine set. **\$300**

The useful reprint of this classic, still-important work. Clain-Stefanelli 1901*. Daehn 1899: "Publishes over 12,000 coins." Grierson 57. Kroh 10. Ex TAB Library.

The Winsemann Falghera Collection

78 Martini, Rodolfo, with Novella Vismara. *MONETAZIONE PROVINCIALE ROMANA II: COLLEZIONE WINSEMANN FALGHERA*. Six volumes, complete. Milano, 1992. 1588 pages; 314 plates. [with] Martini, Rodolfo. *MONETAZIONE PROVINCIALE ROMANA III: BIBLIOGRAFIA GENERALE (FINO AL 1991) - INDICI BIBLIOGRAFICI. 1: BIBLIOGRAFIA GENERALE. 2: INDICI BIBLIOGRAFICI*. Milano, 1992. Two volumes, complete. xxxi, (1), 328, (2); (14), 333628, (2) pages. [with] Martini, Rodolfo. *MONETAZIONE PROVINCIALE ROMANA IV: PRONTUARIO DELLE ZECCHIE PROVINCIALI*. Milano, 1992. xix, (1), 304 pages; maps, tables, and graphs. Nine volumes total. All 8vo, original matching pictorial boards; housed as issued in original black cloth slipcase. Fine. **\$250**

Glaux 8-10. A voluminous catalogue of a private collection of some 3000 Roman provincial coins, described and illustrated, supplemented by a two-volume bibliography on the subject and a one-volume index of the provincial mints. Infrequently available.

Seleucia on the Tigris

79 McDowell, Robert Harbold. **COINS FROM SELEUCIA ON THE TIGRIS.** Ann Arbor: University of Michigan, 1935. 4to, original green cloth, gilt. xiv, 248, (2), ix pages; 6 plates. Spotting to cover and page edges. Very good. **\$100**

An important catalogue of Seleucid, Parthian and other coins found in the late 1920s and early 1930s on the site of Seleucia on the Tigris. *University of Michigan Studies, Humanistic Series*, Volume XXXVII. Clain-Stefanelli 3011. Ex TAB Library.

Coins of the Holy Land

80 Meshorer, Ya'akov, with Gabriela Bijovsky and Wolfgang Fischer-Bossert. **COINS OF THE HOLY LAND: THE ABRAHAM AND MARIAN SOFAER COLLECTION AT THE AMERICAN NUMISMATIC SOCIETY AND THE ISRAEL MUSEUM.** Edited by David Hendin and Andrew Meadows. New York: ANS, 2013. Two volumes. 4to, original matching brown cloth, gilt; jackets. xxvi, 315 (3), (6) pages; 238 plates. Fine. **\$100** *Ancient Coins in North American Collections*, Volume 8. The Sofaer collection includes coinage from the 5th century BC through the Crusades of the 13th century. A number of cultures and peoples are represented, including Greeks, Jews, Persians, Nabataeans, Samaritans, Romans, Byzantines, Arabs, and Europeans.

Important Study of Ancient Jewish Coins

81 Mildenberg, Leo. **THE COINAGE OF THE BAR KOKHBA WAR.** Aarau: Verlag Sauerländer, 1984. Small 4to, original red cloth, gilt; jacket. 396 pages; maps, tables and illustrations; 44 plates of coins. Jacket has small tear; else fine. **\$100** A significant work of limited availability. *Typos: Monographien zur antiken Numismatik*, Band VI. Kroh 60: "a masterpiece of numismatic scholarship, the most exhaustive and complete study ever done on this popular series of Judaic coinage." Ex TAB Library.

Weights of Ancient Greek Coins

82 Mionnet, T.-E. **POIDS DES MÉDAILLES GRECQUES D'OR ET D'ARGENT DU CABINET ROYAL DE FRANCE...** Paris: Chez Crozet, 1839. 8vo, original printed paper covers. (4), vii, 216, (2) pages; tables throughout. Covers spotted; somewhat wrinkled; interiors near fine. **\$100**

A scarce supplementary work by Mionnet, focusing on the metrology of ancient Greek precious metal coins in the French national collection.

Indo-Greek & Indo-Scythian Coins

83 Mitchiner, Michael. **INDO-GREEK AND INDO-SCYTHIAN COINAGE.** London: Hawkins Publications, 1975–1976. Nine volumes, complete. 4to, original matching printed card covers. 1131 pages; maps, tables and numerous coin illustrations throughout. Near fine. **\$120**

A standard reference and the most extensive work ever published on the topic, listing over 10,000 coins. Clain-Stefanelli 3124*. Daehn 6403. Ex TAB Library.

Mitchiner's Oriental Coins and Their Values

84 Mitchiner, Michael. **ORIENTAL COINS AND THEIR VALUES: I. THE WORLD OF ISLAM.** First edition. London, 1998. 511, (1) pages; heavily illustrated throughout. [with]

Mitchiner, Michael. **ORIENTAL COINS AND THEIR VALUES: II. THE ANCIENT & CLASSICAL WORLD, 600 B.C.–A.D. 650.** First edition. London, 1978. 760 pages; heavily illustrated. [with] Mitchiner, Michael. **ORIENTAL COINS AND THEIR VALUES: III. NON-ISLAMIC STATES & WESTERN COLONIES, AD 600–1979.** First edition. London, 1979. 640 pages; heavily illustrated throughout. Three volumes, complete. 4to, original matching blue leatherette, gilt. Near fine. **\$400**

A remarkable series of works, providing a wealth of information. Clain-Stefanelli 5858*. Ex TAB Library.



de Morgan on Oriental Coins of Antiquity

85 Morgan, J. de. **MANUEL DE NUMISMATIQUE ORIENTALE ET L'ANTIQUITÉ ET DU MOYEN AGE.** Tome I. Paris, 1923–1936. 8vo, later black half morocco with marbled sides; spine with five raised bands, ruled and lettered in gilt; all page edges speckled blue. x, 480 pages; 624 text figures. Binding a bit rubbed; near fine. **\$200**

The only volume published of this still-important work. Clain-Stefanelli 3026*. Ex Alain Poinson Library.

M&M Basel Sales of Ancient Coins

86 Münzen und Medaillen Basel / Monnaies et Médailles Bâle. **AUCTION CATALOGUES.** Basel, 1948–2004. Large group of 37 auction catalogues, being numbers: 7, 13, 19, 21, 25, 28, 32, 35, 37–38, 41, 43–44, 47, 52–54, 61, 64, 66, 68, 72–73, 75–77, 79, 81, 85–86, 88–90 and 92–95. Crown 4to, original printed or pictorial card covers; two groups of three catalogues each (38, 41 and 43; 54, 61 and 64) bound together in later blue cloth. A few with original prices realized lists; more with photocopied lists. Generally near fine. **\$200**

An important series of sales featuring significant ancient coins (all of the catalogues here present contain at least some ancient coins). Includes Spring 447, 452, and 455–469 (sales after 1980 are not listed in Spring). Sale 38 featured the highly important August Voiron collection. Sale 47 is listed by Spring under "Most important sales of Celtic coins" and "Most important sales of aes grave." Sales 19, 32, 37, 41, 52, 53 and 54 are listed by Spring under "Most important sales of Greek coins." Sales 19, 38, 43, 44 and 52 are listed by Spring under "Most important sales of struck Roman Republican coins." Sales 13, 28, 38, 43, and 52 are listed by Spring under "Most important sales of Roman Imperial coins." Sales 13, 32 and 41 are listed by Spring under "Most important sales of Roman provincial coins." Sales 28, 35, 38, and 43 are listed by Spring under "Most important sales of Byzantine coins." Ex TAB Library.

The New York Sales: Ancient Coin Catalogues

87 New York Group (Baldwin's, M&M, Italo Vecchi, et al.). **THE NEW YORK SALE.** New York, 1998–2018. Firms vary. Fifteen illustrated catalogues from this series, all of them featuring ancient coins. Includes sales 1–5, 7, 9, 11, 14, 30, 32, 34, 38–40. 4to, original pictorial card covers. Several with prices realized lists laid in. Generally fine. **\$100**

Includes some very important sales. Ex TAB Library.

Nomos Auctions

88 Nomos. **AUCTION CATALOGUES.** Zürich, 2009–2019. Nineteen catalogues, being Nomos Auctions 1–19 except for Nos. 5 and 7, plus Obolos online auctions 3 and 6 (2015 and 2016). Varying formats, original printed or pictorial card covers or boards, as issued. Generally near fine. **\$200**

A remarkable and well-produced series of auction catalogues, expertly catalogued by Dr. Alan S. Walker, Yves Gunzenreiner, and colleagues, and featuring excellent photography. Includes Nomos 4, the BCD Thesaly catalogue. Ex TAB Library.

Scarce NFA Fixed Price Lists

89 Numismatic Fine Arts. **PUBLICATION NOS. 6–21: FIXED PRICE LISTS.** Beverly Hills, 1978–1981. Fifteen fixed price lists bound in one volume. 8vo, later green cloth, gilt; original printed wraps bound in. Fine. **\$100**

The fixed-price catalogues include a number of important coins and are encountered far less often than the firm's auction catalogues. Publication 10 includes a mail-bid sale, for which the prices realized list is bound in. Ex Richard E. Margolis Library.

Rare NFA Julius Caesar Catalogue

90 Numismatic Fine Arts. **JULIUS CAESAR AND HIS LEGACY: AN AUCTION OF ROMAN COINS.** Los Angeles, May 13, 1991. 4to, original pictorial card covers. xvi, 112 pages; 155 lots; illustrated. Near fine. **\$100**

The rarest of the NFA catalogues. The auction, held in Las Vegas, was aimed not at established numismatists (much less other dealers) than to potential investors and prospective clients. The text focuses on the historical background of the coins rather than the numismatic details (which are relegated to the end of the catalogue). Infrequently offered.

Significant Run of Lanz Catalogues

91 Numismatik Lanz/Gitta Kastner. **AUCTION CATALOGUES.** Munich, 1973–2018. Ninety-two illustrated auction sales. Includes Sales 4, 6, 8, 10, 12, 14, 16, 18, 22, 24, 26, 28, 30, 32, 34, 36, 38, 40, 42, 44, 46, 48, 50, 52, 54, 56, 58, 60, 62, 64, 66, 68, 70, 72, 74, 76, 78, 80, 82, 86, 88, 92–94, 97, 99–100, 102, 105–106, 109, 111–112, 114, 116–117, 120–121, 123, 125, 128, 130–132, 134–135, 137–138, 141, 143–151 and 153–166. Small 4to, original printed or pictorial card covers or boards, as issued [Sales 14 and 16 together in later binding]. Also present is Lanz Graz's Sale X (3. Dezember 1977). A number with prices realized lists. Generally fine. **\$300**

An important series of ancient coin sales. Sales 4, 6, 8, 10 & 12 were issued under the Gitta Kastner banner; subsequent auctions were conducted by Dr. Hubert Lanz. Ex TAB Library.

Major Reference on Parthian Coinage

93 Petrowicz, Alexander Ritter von. **SAMMLUNG PETROWICZ. ARSACIDEN-MÜNZEN.** Wien, 1904. 4to, later brown cloth, gilt. (2), vi, (4), 206, (2) pages; 25 fine plates of coins. Fine. **\$300**

The rare original edition of this work, privately printed and limited to 130 copies according to Gustav Fock's 1934 catalogue of the Pick-Gotha library (item 1106). Still important. Clain-Stefanelli 3029*. Daehn 6149: "A catalogue of the author's collection of Parthian coins... Well illustrated." Grierson 90. Ex Herbert Kreindler Library (Kolbe & Fanning Sale 132, lot 1345).

Busso Peus Catalogues

94 Peus Nachf., Dr. Busso. **NUMISMATIC SALE CATALOGUES.** Includes: Catalogues 17–38 bound in two matching volumes; Catalogues 274, 277, 279–280, 282–284, 288–292 and 294, bound in four volumes; and Catalogues 250, 251, 267, 269, 270–271, 299–301, 303, 305, 309–311, 313–315, 318, 320, 322–324, 330–334, 338, 340, 343, 345, 349, 351, 353, 355, 361, 363, 366, 368–369, 371–372 and 374. All of the above 78 catalogues are fully present, whether originally issued in one catalogue or two. Also present are parts (either text or plates) of 11 additional sales. Generally near fine or better. **\$200**

A substantial offering of this firm's sale catalogues, mostly featuring ancient coins. The early catalogues here present (Nos. 17–38) are fixed-price lists, and are infrequently encountered. In later years, Peus catalogues were issued in separate text and plate volumes, which had a tendency to become separated over time. Ex TAB Library.

Scarce 1914 Platt Sale

95 Platt, Clément. **COLLECTION D'UN AMATEUR ÉTRANGER. (2me SÉRIE) MONNAIES ANTIQUES GRECQUES, ROMAINS ET GAULOISES, MONNAIES FRANÇAISES ROYALES & FÉODALES.** Paris, 21–22 avril 1914. 8vo, later blue cloth, gilt; original printed paper covers bound in. 66, (2) pages; 838 lots; 12 fine plates bound in on hinges. Annotated throughout part of the sale in pencil; near fine. **\$100**

A scarce sale catalogue. From the Rollin & Feuarent Library; ex Richard E. Margolis Library. Spring 514.

Raoul-Rochette on Greek Coin Engravers

96 Raoul-Rochette, (Désiré). **LETTRE À M. LE DUC DE LUYNES SUR LES GRAVEURS DES MONNAIES GRECQUES.** Paris, 1831. Tall 4to, original printed card covers. (4), 49, (1) pages; title page with engraved coin image; text engraving; 4 well-engraved but unsigned plates of coins. Unopened. Spotted throughout, particularly at extremities; very good or better. **\$100**

Scarce, with very well-engraved plates. "One of the most learned and prolific archaeologists of the first half of the nineteenth century, Désiré Raoul Rochette (1790–1854), succeeded Millin as Keeper of the Cabinet des Médailles in 1818."—Babelon, 139. Leitzmann 112.

All lots illustrated in full color at

bid.numislit.com

Panvinio's 1557 *Fasti et Triumphi Romanorum*

92 Panvinus, Onuphrius. FASTI ET TRIUMPHI ROM. A ROMULO REGE USQUE AD CAROLUM V. CÆS. AUG. SIVE EPITOME REGUM, CONSULUM, DICTATORUM, MAGISTROR. EQUITUM, TRIBUNORUM MILITUM CONSULARI POTESTATE, CENSORUM, IMPP. & ALIORUM MAGISTRATUUM ROMAN. CUM ORIENTALIUM TUM OCCIDENTALIUM, EX ANTIQUITATUM MONUMENTIS MAXIMA CUM FIDE AC DILIGENTIA DESUMPTA. ONUPHRIO PANVINIO VERONENSI F. AUGUSTINIANO AUTHORE. ADDITÆ SUNT SUIS LOCIS IMPP. & ORIENTALIUM, & OCCIDENTALIUM VERISSIMÆ ICONES, EX VETUSTISSIMIS NUMISMATIS QUAM FIDELISSIMÈ DELINEATÆ. EX MUSÆO JACOBI STRADÆ MANTUANI, CIUIS ROMANI, ANTIQUARIJ. Venetiis: Impensis Jacobi Stradæ Mantuani, 1557. First edition. Folio [31.5 by 20.5 cm], modern full brown antiqued calf in period style; both sides paneled in blind; spine with seven raised bands, ruled and lettered in gilt; board edges hatched in blind; all page edges red. (12), 228, (204) pages [with pages 181–192 repeated twice]; collation agrees with Dekesel, with numerous page numbering errors; 39 pages in the first pagination printed in red and black; finely engraved woodcut printer's device on title; woodcut initials; 371 woodcuts of coins and medals in the text in white on a black ground, depicting Roman, Byzantine and German emperors. A bit tightly trimmed at fore-edge, just grazing a few of the printed marginal notations. Lacking final blank. Binding lightly rubbed, but attractive and skillfully produced. Near fine. **\$1200**

A scarce volume. Onofrio Panvinio (1529–1568), was a polymath, scholar, and Augustinian monk who served as librarian to Cardinal Alessandro Farnese, a great collector of Roman sculpture. Published by the Italian antiquarian Jacob de Strada (1505–1588), this first edition of Panvinio's *Fasti et triumphi* was plagued by production errors, forcing Strada "to find a new publisher to print a corrected, but unillustrated, edition the next year" (*Numismatics in the Age of Grolier*, page 41). John Cunnally (*Images of the Illustrious*, pages 31–32), places the blame for the errors on Strada himself, and states that it was

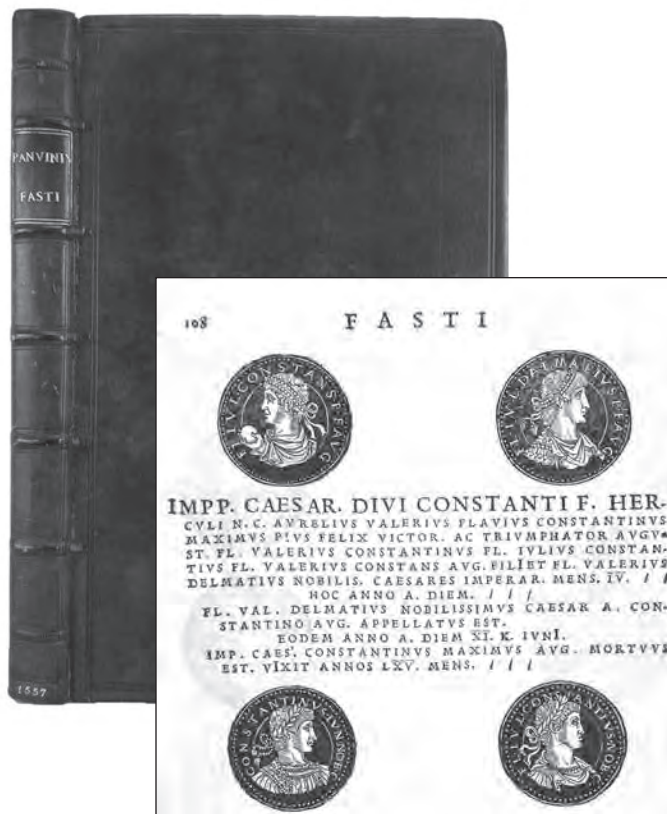

actually Panvinio who sought out another printer for a corrected edition. Cunnally cites letters by Antonio Agustín to Panvinio in which the problem is discussed in some detail. According to Ferdinando Bassoli, this, Panvinio's numismatic magnum opus, is "illustrated with Strada's engravings, set this time in a more serious historical context" (*Antiquarian Books on Coins and Medals*, page 17). Strada's handsome, visually appealing illustrations, originally appearing in 1553, are similar in appearance to those found in Fulvio and Huttich, the first two illustrated numismatic books. Dekesel, in his 1991 study of *Twelve Highlights from the Numismatic Book Collection in the Herzog August Bibliothek (Augusteer) in Wolfenbützel (BRD)*, criticizes the number of pagination errors, but concludes that it remains of some importance, particularly as a production of de Strada utilizing his previous *Epitome thesauri*. Brückmann 105. Dekesel P 16 (earlier state with page 22 numbered 10). Lipsius 305.



Ratinckx on the Art of Roman Coins

97 Ratinckx, J. DE ROMEINSCHE MUNT BESCHOUWD ALS KUNSTVOORTBRENGSEL VAN AF HAAR ONTSTAAN TOT HAAR VERVAL... VERSIERD MET ONGEVEER 750 AFBEELDINGEN. (Antwerp), 1920. Small folio [32.5 by 25.5 cm], later black leatherette, gilt. viii, 104, (6) pages; 35 fine plates depicting Roman Republican and Imperial coins. Fine. **\$500**

A very scarce and interesting study. Issued in folio format in only a paper binding, it would seem that few have survived.

Ratto's 1909 Froehner Collection Sale

98 Ratto, Rodolfo. CATALOGO DI MONETE GRECHE. COLLEZIONE DI UN DOTTO NUMISMATICO STRANIERO. Genova, 26 Aprile 1909 e giorni successivi. 8vo, later red cloth, gilt; marker. xvi, 380 pages; 5795 lots; 21 fine plates of coins; plate of legends. Final three plates with repaired tear; a few plates trimmed too closely. Very good. **\$150**

The important collection of Wilhelm Froehner. Seldom offered. Clain-Stefanelli 1984. Grierson 285. Spring 534.



Dr. Bonazzi's Greek & Late Roman Coins

99 Ratto, Rodolfo. MONNAIES GRECQUES. RICHE COLLECTION, SPÉCIALISÉE DANS LES VILLES DE LA PRESQU'ILE ITALIQUE. Lugano, 25–26 janvier 1926. (4), 74 pages; 828 lots; 34 fine plates. Hand-priced in pencil, with buyers' initials recorded. [bound with] Ratto, Rodolfo. MONNAIES ROMAINES. IMPÉRIALES, BYZANTINES. DEUXIÈME PARTIE: RICHE COLLECTION. Lugano, 7 juin 1926 et jours suivants. iii, (1), 111, (1) pages; lots 1855–3033; 28 fine plates of coins numbered 39–66. Two catalogues, bound in one volume. 8vo, contemporary red quarter calf with mottled sides; spine ruled and lettered in gilt. Very good. **\$300**

Scarce and important, especially with the Greek sale being priced and named. Clain-Stefanelli 2160. Grierson 286 & 309. Spring 541 [also listed under "Most important sales of Roman Imperial coins"] and Spring 542 [also listed under "Most important sales of aes grave"]. According to a penciled note, this volume is from the library of Oscar E. Ravel.

The 1930 Joseph Martini Sale

100 Ratto, Rodolfo. COLLECTION JOSEPH MARTINI DE NEW YORK. MONNAIES DE LA RÉPUBLIQUE ROMAINE. AES GRAVE ET SES RÉDUCTIONS, SÉRIE ROMANO-CAMPANIENNE, LA GUERRE SOCIALE, MONNAIES DES FAMILLES FRAPPÉES A ROME ET EN DEHORS, PREMIÈRE PÉRIODE DE L'EMPIRE ROMAIN JUSQU'A L'ÉPOQUE D'AUGUSTE, LES MONÉTAIRES D'AUGUSTE, AES GRAVE ITALIQUE. Lugano, 24 février 1930 et jours suivants. 4to, original printed card covers, housed within a recent clamshell box [green leatherette and marbled paper, with ties]. (4), 94, (2) pages; 1697 lots; 40 fine plates of coins. Valuation list laid in. Original printed card covers a bit dusty, unopened. Near fine. **\$200**

An important and scarce sale of Roman Republican coins. Clain-Stefanelli 3758. Spring 548 [also listed under "Most important sales of struck Roman Republican coins"].



Beautifully Illustrated Article by Rizzo

101 Rizzo, G.E. QUALCHE OSSERVAZIONE SULL'ARTE DELLE MONETE DI SIRACUSA (DALLE ORIGINI AL NUOVO STILE). *Bolletino d'Arte*, Anno XXXI—Serie III, Numero IX (Marzo 1938), pages 377–402 [entire issue present]. 4to, original printed card covers. Rizzo's article is exceptionally well-illustrated. Some later pages in the issue, not relating to Rizzo's article, show signs of having been damp-stained. Very good. **\$100**

The first copy we recall handling. The numerous illustrations throughout Rizzo's article are of very high quality.

Infrequently Offered Periodical

102 ROMAN COINS AND CULTURE. Volumes I–IV, complete as published in ten issues. Luxembourg, etc., 1985–1990. 4to, original pictorial card covers. Approximately 400 pages; numerous illustrations and coin enlargements. One issue is a display copy. Fine. **\$100**

A well-illustrated periodical begun in Luxembourg and transferring with Volume IV to the United States. Infrequently offered, it struggled for readership despite its interesting content. Ex TAB Library.



1553 Lyon Edition of Rouille's Promptuarium

103 Rouille, Guillaume. PRIMA PARS PROMPTUARIUM ICONUM INSIGNIORUM A SEculo HOMINUM, SUBJECTUS EORUM VITIS, PER COMPENDIUM EX PROBATISSIMIS AUTORIBUS DESUMPTIS / PROMPTUARIUM ICONUM PARS SECONDA INCIPIT A' CHRISTO NATO, PERPETUAM DUCENS SERIEM AD USQUE CHRISTIANISSIMUM FRANCORUM REGEM HENRICUM HOC NOMINE SECUNDUM, HODIE FELICITER REGNANTEM. Lugduni:

Apud Gulielmum Rouillium, 1553. Two parts in one volume. 4to [23.5 by 17.5 cm], early 19th-century black quarter calf, decorated in blind and ruled and lettered in gilt, with marbled sides. (8), 172, (4); 247, (9) pages; 828 finely engraved woodcut medallion portraits, with text below; engraved vignettes on titles; woodcut decorations. Intermittent light spotting and staining; a few signatures sprung. Very good or so. **\$300**

A 16th-century numismatic classic, being the first edition in Latin of Rouille's famous *Promptuarium*, which was printed in Italian and French editions the same year. John Cunnally, in *Images of the Illustrious*, devotes a long section to Guillaume Rouille, observing that though "not a printer himself, Rouille was a grand éditeur who contracted with writers, artists, printers, and retailers to produce blockbuster editions, selecting titles that would appeal to an international audience." Family connections enabled Rouille to distribute books throughout Europe, accounting for the multilingual editions of his *Promptuarium*, and other works which he sold to retailers. Rouille consistently employed the best engravers, and Cunnally notes that, aesthetically, the *Promptuarium* "is very successful with its medallions arranged in pairs at the top third of the page and the text elegantly set below." Brückmann 112 & 118. DeKessel R63. Hirsch 105. Labbé (1675) 11. Lipsius 322. Struve 24.

Seventh Series of the Numismatic Chronicle

104 Royal Numismatic Society. **THE NUMISMATIC CHRONICLE**. Seventh Series. Volumes IV–XX. London, 1964–80. Seventeen consecutive volumes. 8vo, original red cloth, gilt. Generally near fine. **\$200**

One of the truly great scholarly numismatic periodicals, certainly the most important ever published in the English language. Clain-Stefanelli 776. Grierson 19. Ex TAB Library.

Modern Volumes of the Numismatic Chronicle

105 Royal Numismatic Society. **THE NUMISMATIC CHRONICLE**. Volumes 141–171 [series numbering having been discontinued]. London, 1981–2011. Thirty-one consecutive volumes. 8vo, original red cloth, gilt. Generally fine. **\$300**
Clain-Stefanelli 776. Grierson 19. Ex TAB Library.

The First Nine Volumes

106 Royal Numismatic Society [publisher]. **COIN HOARDS**. Volumes I to IX. London: Royal Numismatic Society, 1975–2002. Nine illustrated volumes. Varying hardcover bindings, as published. Near fine or better. **\$200**

An important series. Clain-Stefanelli 16126. Ex TAB Library.

With Articles by Forrer & Sambon

107 Sambon, Arthur [directeur]. **LE MUSÉE: REVUE D'ART MENSUELLE**. Volume IV (1907). 4to, later black cloth, gilt. 400 pages; text illustrations; good quality halftone plates throughout, illustrating a variety of works of art, with a few devoted to ancient coins. One signature loose; binding worn. Very good or so. **\$100**
A rarely encountered journal of the arts that featured numismatic articles on a regular basis. This volume includes Sambon's "La monnaie italique primitive," Forrer's "Tableau du monnayage de Sélinonte," Sambon's "La gravure monétaire en Sicile," and others.

The Martinetti & Nervegna Collections

108 Sambon, Arthur, and C. & E. Canessa. **COLLECTIONS MARTINETTI & NERVEGNA. MÉDAILLES GRECQUES ET**

ROMAINES. AES GRAVE. Rome, 18 novembre 1907 et jours suivants. 4to, original printed card covers. viii, 254, (2) pages; 3184 lots; text figures; 43 fine plates. Opening pages a bit spotted. Very good or better. **\$150**

An important catalogue. Clain-Stefanelli 1744. Grierson 284. Spring 621 [also listed under "Most important sales of Roman Imperial coins"].



Featuring Eleven Syracusan Dekadrachms

109 Sambon, Arthur, and C. & E. Canessa. **CATALOGUE D'UNE COLLECTION DE MONNAIES ANTIQUES GRANDE-GRÈCE & SICILE**. Paris, 19–21 décembre 1907. 4to, later black cloth and marbled boards, gilt. 72 pages; 527 lots; 21 fine plates. Spine weak at junction of text and plates; covers worn. Very good. **\$250**

The very important Giuseppe di Ciccio collection, featuring eleven Syracusan dekadrachms, all finely illustrated, with a 13-page preface by Sambon. Clain-Stefanelli 2156. Grierson 281. Spring 622 [also listed under "Most important sales of ancient Greek coins"]. Ex New York Academy of Sciences, with their bookplate.

Very Rare Sangiorgi Sale of Roman Coins from the Borghesi Collection

110 Sangiorgi, G. **CATALOGO DEL MUSEO BARTOLOMEO BORGHESI. MONETE ROMANE CONSOLARI ED IMPERIALI**. Rome, 19 Gennaio 1893 e seguenti. 8vo, original printed paper covers. iv, 130, (2) pages; 1587 lots; 73 coins illustrated throughout the text. Very good. **\$200**

A remarkably rare catalogue, only the second copy we have been able to offer in thirty years or more. Spring 628.

Schönert-Geiß on Maroneia

111 Schönert-Geiß, Edith. **DIE MÜNZPRÄGUNG VON MARONEIA**. Berlin: Akademie Verlag, 1987. Two volumes (text and plates). Tall 4to, original brown cloth and printed boards, with plates in original matching folder. v, (1), 253, (1) pages; tables; 3 maps; 94 fine plates of coins. Very good. **\$200**
An important contribution to the *Griechisches Münzwerk* series, which continued the work of *Die antiken Münzen Nordgriechenlands* project. *Schriften zur Geschichte und Kultur der Antike*, 26. Daehn 3731.

Senior's Multi-Volume Study

112 Senior, R.C. **INDO-SCYTHIAN COINS AND HISTORY. VOLUME I: AN ANALYSIS OF THE COINAGE. VOLUME II: THE ILLUSTRATED CATALOGUE OF INDO-SCYTHIAN AND INDO-PARTHIAN COINS. VOLUME III: THE 'EASY FINDER' CATALOGUE OF TYPES, MONO-**

GRAMS AND LETTERS APPEARING ON INDO-SCYTHIAN AND INDO-PARTHIAN COINS. VOLUME IV: SUPPLEMENT. Lancaster and London, 2001–2006. Four volumes. 4to, original matching blue boards lettered in silver; jackets. (4), v, (1), 226; (4), xviii, 243, (11); (4), iii, (1), 76, (12); (6), lv, (1), 152 pages; illustrated. Fine. **\$100**

An important work, the main volumes of which are now out of print. Daehn 6470. Ex TAB Library.

Sotheby's Sales of Ancient Coins

113 Sotheby & Co. CATALOGUE OF A VALUABLE COLLECTION OF COINS, CHIEFLY OF ALEXANDER THE GREAT, HIS SUCCESSORS IN NORTH-WEST INDIA, AND OF THE SELEUCID KINGS OF SYRIA. FORMED BY THE LATE MAJOR-GENERAL H.L. HAUGHTON. London, 30 April–1 May 1958. 96 pages; 618 lots; 26 fine plates. [*with*] Sotheby & Co. THE COLLECTION OF GREEK COINS FORMED BY THE LATE FREDERICK J. WOODBRIDGE... [*and*] THE COLLECTION OF ROMAN COINS FORMED BY THE LATE FREDERICK J. WOODBRIDGE... Zürich, 7 May 1975. Two catalogues. 345 lots total; 9 + 13 plates. Greek sale with prices realized list. [*with*] Sotheby Parke Bernet & Co. CATALOGUE OF THE COLLECTION OF HIGHLY IMPORTANT GREEK AND ROMAN COINS FORMED BY PATRICK A. DOHENY. London, 20 June 1979. (2), v, (93) pages; 245 lots; illustrations throughout, a number in color. Prices realized list laid in. Also included are five additional sales, three with price lists, dated: 23 June 1971; 16 February 1977; 13 July 1977; 26 October 1977; and 16 December 1977. All in original bindings. Generally very good to near fine. **\$100**

Includes some scarce and important sales. Present are Spring 831, 841, 842 and 847. Ex TAB Library.

Notable Sotheby's Auctions

114 Sotheby & Co. A.G. THE COLLECTION OF ANCIENT AND LATER COINS, THE PROPERTY OF THE METROPOLITAN MUSEUM OF ART. PART I: ROMAN GOLD COINS. [*and*] PART II: GREEK COINS FROM THE JOHN WARD COLLECTION. Zurich, 10th November 1972 and 4th–5th April 1973. Two catalogues, with price lists. Color frontispieces; (110), (132) pages; maps; text illustrations; 38 plates. [*with*] Sotheby's. AN IMPORTANT SYRACUSAN DECADRACHM BY CIMON. New York, December 4, 1990. (8) pages; 1 lot; illustrated in color. [*with*] Sotheby's. TWO HUNDRED HIGHLY IMPORTANT GREEK AND ROMAN COINS. London, July 5, 1995. 167, (9) pages; 200 lots; illustrated. Prices realized list laid in. [*with*] Sotheby's. HIGHLY IMPORTANT GREEK AND ROMAN COINS. London, July 8, 1996. 117, (11) pages; 193 lots; illustrated. Also included are five additional sales, three of them with prices, dated: 23 November 1977; 16 December 1977; 28 November 1986; 12–12 novembre 1990; and 27–28 October 1993. Generally near fine. **\$100**

Present are some very important sales. The 1972–1973 Metropolitan Museum of Art sales are Spring 837 and 838 [838 also listed under “Most important sales of ancient Greek coins”; 837 listed under “Most important sales of Roman Imperial coins”] The Ward collection sale is Daehn 1945. Ex TAB Library.

Frank Sternberg Coin Sales

115 Sternberg, Frank. AUCTION CATALOGUES. Zürich, 1973–2000. A fine group of thirty illustrated auction catalogues, including the firm's Sales I, III, VI–IX, XI–XXII, XXIV–XXIX, XXXI–XXXV and its Mail Bid Sale I. Lacking only six catalogues (some non-numismatic) for completion. 8vo, as originally issued in either cloth-backed printed boards (12), or printed card covers (18). Some with prices realized lists. Generally near fine. **\$200**

An important series of catalogues for ancient coins, many issued in limited numbers, by one of the major international coin dealers of the twentieth century. Some were issued in association with other firms. Includes Spring 865–866 and 868–870. Ex TAB Library.

Roman Coinage in the Time of Trajan

116 Strack, Paul L. UNTERSUCHUNGEN ZUR RÖMISCHEN REICHSPRÄGUNG DES ZWEITEN JAHRHUNDERTS. TEIL I: DIE REICHSPRÄGUNG ZUR ZEIT DES TRAIAN. Stuttgart: Kohlhammer, 1931. 4to, original printed card covers. xi, 308 pages; folding tables; 10 fine plates of coins. Spine and covers worn; some corner folds affecting plate margins. Very good or so. **\$100**

The first volume of this important work. Quite scarce. Clain-Stefanelli 4189*. Grierson 78. Kroh 79 (four stars): “a type-corpus of the coinage and covers it in much more detail than does any other reference.”



Nearly Complete Set of Svoronos's Journal

117 Svoronos, Joannes N. [editor]. JOURNAL INTERNATIONAL D'ARCHÉOLOGIE NUMISMATIQUE. Tome 1–3, 5–21 (Athens, 1898–1927). A nearly complete set, lacking only the following: Tome 4; Parts 1 & 2 of Tome 7; Parts 1 & 2 of Tome 8; and the first 32 pages of Tome 11. 4to [size varies slightly], original printed paper covers. Half or so of the volumes present have bindings that are failing. Tome 21 is damp-stained. Most volumes very good. **\$600**

A nearly complete set of this important journal, rarely offered complete. An indispensable storehouse of information, particularly on ancient Greek coins, featuring thousands of pages of text and hundreds of fine plates. The volumes, while well-printed and with excellent plates, were insubstantially bound, resulting in a poor survival rate. Many important articles first appeared in this publication. Clain-Stefanelli 629. Grierson 19. Ex Eric P. Newman Library.

Reprint of Svoronos on Crete

118 Svoronos, J.-N. NUMISMATIQUE DE LA CRÈTE ANCIENNE. Bonn, 1972 reprint. 4to, original blue cloth, gilt. (6), ix, 376, (2), (2) pages; 38 plates. Binding somewhat worn; previous owner's ink stamp. Very good or better. **\$100**

The infrequently seen reprint of the rare and important 1890 original. Clain-Stefanelli 2581*. Grierson 62.

SNG Austria: Sammlung Dreer

119 Sylloge Nummorum Graecorum. SYLLOGE NUMMORUM GRAECORUM. SAMMLUNG DREER / KLAGENFURT IM LANDESMUSEUM FÜR KÄRNTEN. I. TEIL: ITALIEN-SIZILIEN. [with] II. TEIL: SPANIEN-GALLIEN. KELTEN-LÄNDER. [with] III. TEIL: THRACIEN-MACEDONIEN. PÄONIEN. Klagenfurt: Geschichtsverein für Kärnten, 1967, 1984 and 1990. First editions. Three volumes, complete. Folio, original cloth-backed printed card covers. 12 + (8) + (8) pages; text illustrations and portraits; 15 + 9 + 27 plates of coins, each with a leaf of facing descriptive text. Concordance laid into first volume. Title written on two spines. Near fine. **\$150**

All three parts, complete. Depicts 1508 coins. Clain-Stefanelli 1918*. Daehn 1964. Kroh 15.

SNG Austria: Sammlung Leypold

120 Sylloge Nummorum Graecorum. SYLLOGE NUMMORUM GRAECORUM. ÖSTERREICH. SAMMLUNG LEYPOLD, WIENER NEUSTADT. KLEINASIATISCHE MÜNZEN DER KAISERZEIT. BAND I: PONTUS-LYDIEN. [with] BAND II: PHRYGIEN-KOMMAGENE Wien: Österreichische Forschungsgesellschaft für Numismatik, 2000 and

2004. First editions. Two volumes, complete. 4to, original matching crimson boards, gilt. 203, (5) + 304 pages; illustrated with facing text. Near fine. **\$100**

Both parts, complete. Depicts 2846 coins. Daehn 1965.

SNG Belgium

121 Sylloge Nummorum Graecorum. SYLLOGE NUMMORUM GRAECORUM. BELGIQUE. BIBLIOTHÈQUE ROYALE DE BELGIQUE. LA COLLECTION DE BRONZES GRECS DE MARC BAR. Bruxelles, 2007. 4to, original blue cloth, gilt. 276, (2) pages, including 97 plates with facing descriptions. Erratum laid in. Fine. **\$100**

Includes considerable textual commentary on the collection. Depicts 1373 coins. Daehn 1966.

SNG Denmark: Copenhagen

122 Sylloge Nummorum Graecorum. SYLLOGE NUMMORUM GRAECORUM. THE ROYAL COLLECTION OF COINS AND MEDALS, DANISH NATIONAL MUSEUM. Reprint. West Milford: Sunrise Publications, 1981-1992. Forty-three fascicules, complete, excellently reproduced and bound in eight volumes. Folio, original matching crimson cloth, gilt. 538 full-page plates of coins with descriptive text, depicting 22,012 coins. Near fine. [with] Sylloge Nummorum Graecorum. SYLLOGE NUMMORUM GRAECORUM. THE ROYAL COLLECTION OF COINS AND MEDALS, DANISH NATIONAL MUSEUM. SUPPLEMENT. ACQUISITIONS 1942-1996. Copenhagen, 2002. Folio, original printed gray card covers. 54 plates with text. Near fine. **\$300**

Indispensable. The eighth reprint volume reprints Fascicles 40-43 and

SNG Germany: München

125 Sylloge Nummorum Graecorum. SYLLOGE NUMMORUM GRAECORUM. DEUTSCHLAND. STAATLICHE MÜNZSAMMLUNG MÜNCHEN. A complete set of all sixteen volumes published so far:

- | | |
|----------------------------------------------------------------------------------------------|-------------------------------------------------------------|
| 1. HISPANIA, GALLIA NARBONENSIS. 17 plates. | 10./11. MAKEDONIEN: KÖNIGE. 52 plates. |
| 2. ETRURIA, UMBRIA, PICENUM, LATIUM, SAMNIUM, PRENTANI, CAMPANIA, APULIA. 17 plates. | 12. HEFT: THESSALIEN, ILLYRIEN, EPIRUS, KORKYRA. 36 plates. |
| 3. KALABRIEN, LUKANIEN. 41 plates. | 14. ATTIKA, MEGARIS, ÄGINA. 21 plates. |
| 4. BRUTTIUM, KARTHAGER IN ITALIEN. 41 plates. | 19. TROAS-LESBOS. 29 plates. |
| 5. HEFT: SIKELIA. 25 plates. | 20. IONIEN. 29 plates. |
| 6. SIKELIA, PUNIER IN SIZILIEN, LIPARA, SARDINIA, PUNIER IN SARDINIEN, NACHTRÄGE. 51 plates. | 22. HEFT: KARIEN. 36 plates. |
| 7. TAURISCHE CHERSONES. 20 plates. | 23. LYDIEN. 35 plates. |
| | 24. PHRYGIEN. 21 plates. |
| | 28. SYRIEN: NICHT-KÖNIGLICHE PRÄGUNGEN. 46 plates. |

Berlin 1968-2007. All folios, original printed card covers. Generally fine or nearly so. **\$900**

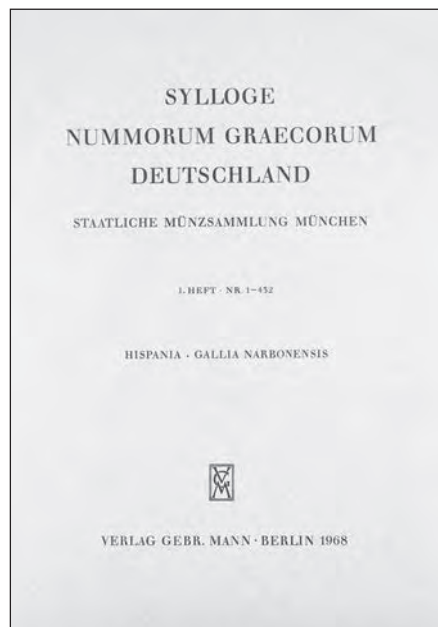

All sixteen fascicules so far published of this extensive SNG series. Clain-Stefanelli 1915*. Daehn 1989. Kroh 13 (four stars). Ex TAB Library.

is only occasionally present. The supplementary volume was published after the reprint's eighth and final volume appeared, and is necessary to complete the set. Clain-Stefanelli 1912*. Daehn 1982 and 1983. Grierson 56. Kroh 13 (five stars): "It is the largest and most complete of all SNG's and it utilized extensively by both scholars and the trade. The coverage is extensive and both the quality of material as well as the research is very good." Ex TAB Library.

SNG Finland

123 Sylloge Nummorum Graecorum. SYLLOGE NUMMORUM GRAECORUM. FINLAND. THE ERKKI KECKMAN COLLECTION IN THE SKOPBANK, HELSINKI. PART I: KARIA. [with] PART II: ASIA MINOR EXCEPT KARIA. Helsinki: Finnish Society of Sciences and Letters, 1994 and 1999. Two volumes, complete. 4to, original matching blue cloth, gilt. (3), (3), (5), (3) pages; 32 + 32 plates of coins, each with a page of facing descriptive text. First volume covers a bit spotted; else near fine. **\$100** Both parts of this notable collection, illustrating 1747 coins. Daehn 1986. Ex TAB Library.

SNG France

124 Sylloge Nummorum Graecorum. SYLLOGE NUMMORUM GRAECORUM. FRANCE 2. CABINET DES MÉDAILLES. CILICIE. [with] FRANCE 3. CABINET DES MÉDAILLES. PAMPHYLIE, PISIDIE, LYCAONIE, GALATIE. [with] FRANCE 4. DÉPARTEMENT DES MONNAIES, MÉDAILLES ET ANTIQUES. ALEXANDRIE I. AUGUSTE-TRAJAN. [with] FRANCE 5. DÉPARTEMENT DES MONNAIES, MÉDAILLES ET ANTIQUES. MYSIE. [with] FRANCE 6.1. DÉPARTEMENT DES MONNAIES, MÉDAILLES ET ANTIQUES. ITALIE. ÉTRURIE - CALABRE. Paris: Bibliothèque Nationale/Numismatica Ars Classica, 1993, 1994, 1998, 2001 and 2003. Five volumes total. Tall 4to, original matching crimson cloth, gilt; jackets. Preliminary and supplementary text, with 137 + 146 + 105 + 136 + 141 plates of coins, each with a page of facing descriptive text; *Index Alphabétique* laid in to first volume. Jacket a bit worn, two of them with notations; otherwise near fine. **\$400**

The SNG France volumes are among the best in terms of technical production. These volumes describe and illustrate 11,284 coins. Daehn 1987. Kroh 14.

SNG Germany: Tübingen 1-6

126 Sylloge Nummorum Graecorum. SYLLOGE NUMMORUM GRAECORUM. MÜNZSAMMLUNG DER UNIVERSITÄT TÜBINGEN. 1. HEFT: HISPANIA-SIKELIA. NR. 1-730. [with] 2. HEFT: TAURISCHE CHERSONES-KORKYRA. NR. 731-1542. [with] 3. HEFT: AKARNANIEN-BITHYNIEN. NR. 1543-2173. [with] 4. HEFT: MYSIEN-IONIEN. NR. 2174-3306. [with] 5. HEFT: KARIEN UND LYDIEN. NR. 3307-3886. [with] 6. HEFT: PHRYGIEN-KAPPADOKIEN. RÖMISCHE PROVINZPRÄGUNGEN IN KLEINASIEN. NR. 3887-4744. Berlin, 1981-1998. Six volumes, complete. All folio, original printed brown card covers. Preliminary and supplementary text, with 30 + 25 + 23 + 31 + 20 + 33 plates of coins, each with a page of facing descriptive text. Fine. **\$400**

All six volumes in this SNG series, illustrating 4744 coins. Clain-Stefanelli 1915a. Daehn 1990. Kroh 14. Ex TAB Library.

SNG Germany: von Aulock

127 Sylloge Nummorum Graecorum. SYLLOGE NUMMORUM GRAECORUM. DEUTSCHLAND. SAMMLUNG V. AULOCK. West Milford: Sunrise Publications, 1987 reprint in four volumes. Folio, original matching blue cloth, gilt. 304 plates depicting 8739 ancient Greek coins from Asia Minor, with facing text. Near fine. [with] DEUTSCHLAND. SAMMLUNG V. AULOCK. INDEX. Berlin, 1981. 4to, original crimson cloth lettered in silver; jacket. xii, 268 pages; 12 large double fold-out charts. Fine. **\$250**

The useful reprint of this outstanding reference to the Greek coins of Asia Minor, the Hans von Aulock collection. Clain-Stefanelli 1914*. Daehn 1988. Grierson 56. Kroh 13. Ex TAB Library.

SNG Great Britain: Fitzwilliam

128 Sylloge Nummorum Graecorum. SYLLOGE NUMMORUM GRAECORUM. VOLUME IV: FITZWILLIAM MUSEUM: LEAKE AND GENERAL COLLECTIONS. PART I: SPAIN (EMPORIA, RHODA)-ITALY. [with] PART II: SICILY-THRACE. [with] PART VIII: SYRIA-NABATHAEA. London: Published for the British Academy, 1971-1972. Three volumes. Folio, original cloth-backed boards. Hand-lettered spines. Near fine. **\$120**

Three volumes of this important SNG series. Clain-Stefanelli 1913*. Daehn 1971. Kroh 14. Ex TAB Library.

SNG Great Britain: Ashmolean

129 Sylloge Nummorum Graecorum. SYLLOGE NUMMORUM GRAECORUM. VOLUME V: ASHMOLEAN MUSEUM. PART I(A): ITALY. ETRURIA-LUCANIA (THURIUM). [with] PART II: ITALY. LUCANIA (THURIUM)-BRUTTIUM. SICILY. CARTHAGE. [with] PART III: MACEDONIA. [with] PART IV: PAEONIA-THESSALY. London: Published for the British Academy, 1962-1981. First editions. 82 fine plates of coins, each with a leaf of facing descriptive text. Four volumes. All folio, original printed brown card covers or cloth-backed boards, as issued. Titles written on spines in ink, else near fine. [with] Sylloge Nummorum Graecorum. SYLLOGE NUMMORUM GRAECORUM. VOLUME V: ASHMOLEAN MUSEUM. OXFORD. PART IX: BOSPORUS-AEOLIS. Oxford: Published for the British Academy, 2007. First edition. 4to, original russet cloth, gilt. (10) pages; 59 plates, each with a page of facing descriptive text. Fine. **\$250**

Five volumes in all. The initial Part I (published in 1951) focused purely on the Evans collection coins. In the succeeding years, so many more coins were acquired by the Ashmolean that the organizers realized that a full presentation made more sense than the sectional approach at first utilized, so the series began anew with Volume I(A). Clain-Stefanelli 1913*. Daehn 1972. Kroh 14.

SNG Great Britain: Lewis

130 Sylloge Nummorum Graecorum. SYLLOGE NUMMORUM GRAECORUM. VOLUME VI: THE LEWIS COLLECTION IN CORPUS CHRISTI COLLEGE. CAMBRIDGE. PART I: THE GREEK AND HELLENISTIC COINS (WITH BRITAIN AND PARTHIA). [with] PART II: THE GREEK IMPERIAL COINS. London: Published for the British Academy, 1972 and 1992. First editions. Two volumes, complete. Folio,

original printed brown cloth-backed boards and russet cloth, gilt. (9), (1), 10 + (7), (9) pages; 24 + 24 plates of coins, each with a page of facing descriptive text. First volume with hand-lettered spine. Fine. **\$100**

Both volumes of this SNG series. Clain-Stefanelli 1913*. Daehn 1973. Kroh 15. Ex TAB Library.

SNG Great Britain Volumes

131 Sylloge Nummorum Graecorum. SYLLOGE NUMMORUM GRAECORUM. VOLUME VII: MANCHESTER UNIVERSITY MUSEUM. THE RABY AND GÜTERBOCK COLLECTIONS. London: Published for the British Academy, 1986. First edition. 4to, original brown boards, gilt. 135, (1) pages, including 57 plates of coins, each with a page of facing descriptive text. Review affixed to front flyleaf, else fine. [with] Sylloge Nummorum Graecorum. volume VIII: THE HART COLLECTION. BLACKBURN MUSEUM. Oxford: Published for the British Academy, 1989. First edition. 4to, original russet boards, gilt. (13), (7) pages; 56 plates of coins, each with a page of facing descriptive text. Fine. [with] Sylloge Nummorum Graecorum. VOLUME X: THE JOHN MORCOM COLLECTION OF WESTERN GREEK BRONZE COINS. Oxford: Published for the British Academy, 1995. First edition. 4to, original brown cloth, gilt. (7), (13) pages; 38 plates of coins, each with a page of facing descriptive text. Fine. [with] Sylloge Nummorum Graecorum. VOLUME XIII: THE COLLECTION OF THE SOCIETY OF ANTIQUARIES. NEWCASTLE UPON TYNE. Oxford: Published for the British Academy, 2005. First edition. 4to, original russet cloth, gilt. (13), (1) pages; 48 plates of coins, each with a page of facing descriptive text. Fine. **\$150**

Four volumes of the British SNG series, each composed of a single part. Daehn 1974, 1975, 1977 and 1980.

SNG Great Britain: British Museum

132 Sylloge Nummorum Graecorum. SYLLOGE NUMMORUM GRAECORUM. VOLUME IX. THE BRITISH MUSEUM. PART 1: THE BLACK SEA. [with] PART 2: SPAIN. London: British Museum Press, 1993 and 2002. First editions. Two volumes, complete. 4to, original matching blue cloth, gilt. (9), (9) + 215, (1) pages; map; 59 + 80 plates of coins, each with a page of facing descriptive text [second volume plates included in pagination]. Fine. **\$150**

Important volumes, with the Black Sea fascicle being particularly notable. Daehn 1976. Ex TAB Library.

SNG Great Britain: Stancomb

133 Sylloge Nummorum Graecorum. SYLLOGE NUMMORUM GRAECORUM. VOLUME XI: THE WILLIAM STANCOMB COLLECTION OF COINS OF THE BLACK SEA REGION. Oxford: Published for the British Academy, 2000. First edition. 4to, original brown cloth, gilt. (11), (21) pages; map; 53 plates of coins, each with a page of facing descriptive text. Fine. **\$150**

Out of print and in demand. Daehn 1978. Ex TAB Library.

SNG Great Britain: Hunterian

134 Sylloge Nummorum Graecorum. SYLLOGE NUMMORUM GRAECORUM. VOLUME XII: THE HUNTERIAN MUSEUM. UNIVERSITY OF GLASGOW. PART I: ROMAN PROVINCIAL COINS. SPAIN-KINGDOMS OF ASIA MINOR. [with] PART II: ROMAN PROVINCIAL COINS: CYPRUS-EGYPT. Oxford: Published for the British Academy, 2004 and 2007. Two volumes, complete. 4to, original matching russet cloth, gilt. (27), (67) + 377, (1) pages; 173 + 158 plates of coins, each with a page of facing descriptive text [second volume plates included in pagination]. Fine. **\$100**

Both parts of this SNG series, important for Roman provincial issues. Daehn 1979. Ex TAB Library.

SNG Greece: Evelpidis

135 Sylloge Nummorum Graecorum. GRÈCE. COLLECTION RÉNA H. EVELPIDIS. ATHÈNES. PREMIÈRE PARTIE: ITALIE-SICILE-THRACE. Louvain: British Academy, 1970. Folio, original cloth-backed printed brown boards. (9), (1) pages; 31 fine plates of coins, each with a page of facing descriptive text. [with] Sylloge Nummorum Graecorum. GRÈCE. COLLECTION RÉNA H. EVELPIDIS. ATHÈNES. DEUXIÈME PARTIE: MACÉDOINE-THESSALIE-ILLYRIE-ÉPIRE-CORCYRE. Louvain: British Academy, 1975. Folio, original yellow cloth-backed plasticized printed brown boards. (5), (1) pages; 23 fine plates of coins, each with a page of facing descriptive text. Bindings worn, but contents near fine. **\$100**

Infrequently offered. Clain-Stefanelli 1919*. Daehn 1994. Kroh 14. Ex TAB Library.

SNG Greece Volumes

136 Sylloge Nummorum Graecorum. SYLLOGE NUMMORUM GRAECORUM. GREECE II. THE ALPHA BANK COLLECTION. MACEDONIA I: ALEXANDER I-PERSEUS. [with] GRÈCE 3: MUSÉE NUMISMATIQUE D'ATHÈNES. COLLECTION ANTOINE CHRISTOMANOS. PREMIÈRE PARTIE: ITALIE-EUBÉE. PAR MANDO ŒCONOMIDÈS. [with] GREECE 4: NUMISMATIC MUSEUM, ATHENS. THE PETROS Z. SAROGLOS COLLECTION. VOLUME I: MACEDONIA. [with] GREECE 7. THE KIKPE COLLECTION OF BRONZE COINS. VOLUME I. Athens, 2000-2012. Four volumes. 4to, original blue cloth, gilt. Preliminary and supplementary text, with 53 + 44 + 52 + 126 plates of coins, each with a page of facing descriptive text. Generally fine. **\$300**

Four of the six volumes published to date of the more recent Greek series. Daehn 1995-1997. Ex TAB Library.

SNG Russia & Slovenia

137 Sylloge Nummorum Graecorum. SYLLOGE NUMMORUM GRAECORUM. STATE PUSHKIN MUSEUM OF FINE ARTS. COINS OF THE BLACK SEA REGION. PART I. ANCIENT COINS FROM THE NORTHERN BLACK SEA LITORAL. Leuven: Peeters, 2011. First edition. 4to, original pictorial boards. xvi, 192 pages, including 90 plates of coins, each with a page of facing descriptive text. Fine. [with] Sylloge Nummorum Graecorum. SYLLOGE NUMMORUM GRAECORUM. SLOVENIA. LJUBLJANA. NARODNI MUZEJ. VOLUME III: MOE-

Visit our online store at
numislit.com
to browse even more titles

SIA SUPERIOR. COLLECTION KECSKÉS. PART 1: VIMINACIUM. Milano: Edizioni Ennere, 1996. First edition. 4to, original blue boards lettered in black. (7), (5) pages; 120 plates of coins, each with a page of facing descriptive text. Fine. **\$100**

The first illustrates 1870 coins issued by the Greek cities of the Northern Black Sea littoral, while the second illustrates 2381 coins of Viminacium. Daehn 2005 (second title).

SNG Spain & Italy

138 Sylloge Nummorum Graecorum. SYLLOGE NUMMORUM GRAECORUM. ESPAÑA. MUSEO ARQUEOLÓGICO NACIONAL. MADRID. VOLUMEN I: HISPANIA. CIUDADES FENO-PÚNICAS. PARTE 1: GADIR Y EBUSUS. CARMEN ALFARO ASINS. [with] VOLUMEN II: HISPANIA. CIUDADES DEL ÁREA MERIDIONAL. ACUÑACIONES CON ESCRITURA INDÍGENA. Madrid, 1994 and 2005. Two volumes. 4to, original matching russet cloth, gilt; jackets. Preliminary and supplementary text, with 40 + 92 plates of coins, each with a page of facing descriptive text. Fine. [with] Sylloge Nummorum Graecorum. SYLLOGE NUMMORUM GRAECORUM. ITALIA. FIRENZE. MUSEO ARCHEOLOGICO NAZIONALE. VOLUME II: ETRURIA. Firenze, 2007. First edition. 4to, original red boards lettered in black. 221, (1) pages, including 66 plates of coins, each with a page of facing descriptive text. Fine. **\$120**

The Spanish volumes illustrate 986 and 1501 coins, respectively. Daehn 2006 and 2007. The Florence volume illustrates 1173 Etruscan pieces. Daehn 2002a.

SNG Sweden I

139 Sylloge Nummorum Graecorum. SYLLOGE NUMMORUM GRAECORUM. SWEDEN I: THE COLLECTION OF HIS LATE MAJESTY KING GUSTAF VI ADOLF. THE FRED FORBAT COLLECTION. Stockholm: Kungl. Vitterhets Historie och Antikvitets Akademien, 1974. Folio, original printed brown card covers. 49, (3), pages; including 19 plates of coins, each with a page of facing descriptive text. Title written on spine, else near fine. [with] Sylloge Nummorum Graecorum. SYLLOGE NUMMORUM GRAECORUM. SWEDEN. I:2. SAMMLUNG ERIC VON POST. Stockholm: Kungl. Myntkabinettet, 1995. Tall 4to, original green cloth, gilt. (3), (5) pages; 33 plates of coins, each with a page of facing descriptive text. Near fine. **\$100**

Both fascicles of the first SNG Sweden volume. Clain-Stefanelli 1921*. Daehn 2008. Kroh 14.

SNG Sweden II

140 Sylloge Nummorum Graecorum. SYLLOGE NUMMORUM GRAECORUM. SWEDEN II. THE COLLECTION OF THE ROYAL COIN CABINET NATIONAL MUSEUM OF MONETARY HISTORY STOCKHOLM. PART I: GALLIASICILY. [with] PART 2: THRACE-EUBOIA. Stockholm: Royal Academy of Letters History and Antiquities, 1976 and 1980. First editions. Two volumes. Both folio, original printed brown card covers. Preliminary and supplementary text, with 19 + 20 plates of coins, each with a page of facing descriptive text. Near fine. **\$100**

Two fascicles of the second SNG Swedish volume. Clain-Stefanelli 1920*. Daehn 2009. Kroh 14.

SNG Sweden II.6

141 Sylloge Nummorum Graecorum. SWEDEN II. THE COLLECTION OF THE ROYAL COIN CABINET, NATIONAL MUSEUM OF ECONOMY, STOCKHOLM. PART 6: THE G.D. LORICHS COLLECTION. Stockholm: Royal Academy of Letters History and Antiquities, 2003. Tall 4to, original printed russet cloth, gilt. (7), (5) pages; portrait of Lorichs; 113 plates of coins, each with a page of facing descriptive text. Errata slip laid in. Fine. **\$100**

The most recently published fascicle of this Swedish SNG volume. Daehn 2009. Ex TAB Library.

SNG Switzerland I with Supplement

142 Sylloge Nummorum Graecorum. SYLLOGE NUMMORUM GRAECORUM. SWITZERLAND I: LEVANTE-CILICIA. [with] SUPPLEMENT I. Berne and Zürich, 1986 and 1993. First editions. Two volumes, complete. Both 4to, original matching crimson cloth, gilt; jacket. Preliminary and supplementary text, with 125 + 35 plates of coins, each with a page of facing descriptive text. *Alphabetical Index* laid into both volumes. Some annotations; near fine. **\$100**

Daehn 2010 and 2011. Kroh pages 13 and 14 (four stars): "This is by far technically the finest product of the entire SNG series and perhaps the best specialized collection ever published. The Edoardo Levante collection consists of 1,861 coins exclusively from Cilicia in Asia Minor." The Supplement adds a further 435 coins. Ex TAB Library.

SNG Switzerland II

143 Sylloge Nummorum Graecorum. SYLLOGE NUMMORUM GRAECORUM. SCHWEIZ II: MÜNZEN DER ANTIKE. KATALOG DER SAMMLUNG JEAN-PIERRE RIGHETTI IM BERNISCHEN HISTORISCHEN MUSEUM, BALÁZS KAPOSSY. Bern: Verlag Paul Haupt, 1993. First edition. 4to, original crimson cloth, gilt; jacket. (21), (1) pages; 208 plates of coins, each with a page of facing descriptive text. Fine. **\$100**

Daehn 2012: "Publishes 3084 coins, with an emphasis on Roman Provincial mints." Ex TAB Library.

SNG Turkey

144 Sylloge Nummorum Graecorum. SYLLOGE NUMMORUM GRAECORUM. TURKEY 1: THE MUHARREM KAYHAN COLLECTION. [with] TURKEY 2: ANAMUR MUSEUM. VOLUME 1: ROMAN PROVINCIAL COINS. [with] TURKEY 3: ÇANAKKALE MUSEUM. VOLUME 1: ROMAN PROVINCIAL COINS OF MYSIA, TROAS, ETC. [with] TURKEY 4: ANCIENT COINS FROM MYSIA, TROAD AND AEO-LIS IN THE COLLECTION OF SELÇUK TANRIKULU. [with] TURKEY 5: TIRE MUSEUM. VOLUME 1. ROMAN PROVINCIAL COINS FROM IONIA, LYDIA, PHRIGIA AND, ETC. [with] TURKEY 7: ÖDEMIS MUSEUM. VOLUME 1. ROMAN PROVINCIAL COINS OF IONIA, LYDIA AND ETC. [with] TURKEY 8: MUGLA MUSEUM. VOLUME I. GARIA. Istanbul, 2002–2012. Seven volumes. All 4to, original blue cloth, gilt. Preliminary and supplementary text, with 41 + 40 + 42 + 24 + 40 + 30 + 15 plates of coins, each with a page of facing descriptive text. Near fine or better. **\$250**

Seven of the nine volumes published to date of the Turkish SNG series, lacking only Parts 6 and 9 for completion. Daehn 2013–2016.

SNG United States: ANS

146 Sylloge Nummorum Graecorum. SYLLOGE NUMMORUM GRAECORUM. THE COLLECTION OF THE AMERICAN NUMISMATIC SOCIETY. PARTS 1–9. New York: The American Numismatic Society, 1969–1998. First editions. Nine volumes complete, as follows:

PART 1: ETRURIA–CALABRIA. 1969.

PART 2: LUCANIA. 1972.

PART 3: BRUTTIUM-SICILY I: ABACAENUM–ERYX. 1975.

PART 4: SICILY II: GALARIA–STYELLA. 1977.

PART 5: SICILY III: SYRACUSE–SICELIOTES. 1988.

PART 6: PALESTINE–SOUTH ARABIA. 1981.

PART 7: MACEDONIA I: CITIES, THRACO-MACEDONIAN TRIBES, PAEONIAN KINGS. 1987.

PART 8: MACEDONIA II: ALEXANDER I–PHILIP II. 1994.

PART 9: GRAECO-BACTRIAN AND INDO-GREEK COINS. 1998.

Nine folio or quarto volumes, comprising 388 fine plates depicting 11,991 coins, accompanied by introductory and descriptive text. Parts 1–6 in folio; Parts 7–9 in quarto. Parts 1–3 in the original printed russet card covers; Parts 4–5 in the original printed russet boards; Part 6 being the special binding in cream linen; Parts 7–9 in the original russet cloth, gilt.

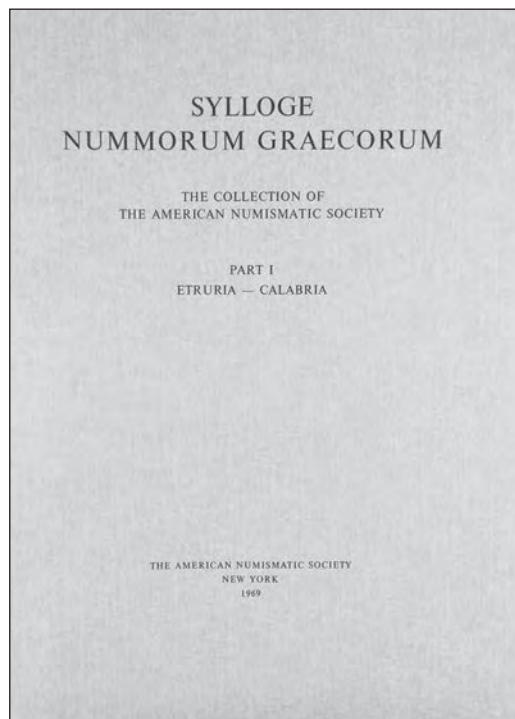

A fine set.

\$500

The complete SNG series for the American Numismatic Society collection. Clain-Stefanelli 1917* (Parts 1–5). Daehn 1962. Kroh 13 (four stars): “This collection is one of the best in the world and both the scope and scholarship of these volumes are excellent.” Ex TAB Library.

SNG United States: Berry

145 Sylloge Nummorum Graecorum. SYLLOGE NUMMORUM GRAECORUM. THE BURTON Y. BERRY COLLECTION. PART I: MACEDONIA TO ATTICA. [with] PART II: MEGARIS TO EGYPT. New York: ANS, 1961–1962. Two parts, complete. Folio, original matching printed card covers. (5), (1); (3), (1) pages; 58 fine plates depicting 1506 coins, each with a page of facing descriptive text. Near fine.

\$100

The first two American contributions to the SNG series. Clain-Stefanelli 1916*. Daehn 1961. Kroh 14: “an excellent and varied collection with many unusual and artistic items.” Ex TAB Library.

Multinational Sasanian Sylloge

147 Sylloge Nummorum Sasanidarum. SYLLOGE NUMMORUM SASANIDARUM PARIS–BERLIN–WIEN. VOLUMES 1–4. Wien: Österreichischen Akademie der Wissenschaften, 2003–2012. By Michael Alram, Rika Gyselen and Nikolaus Schindel. Four volumes. 4to, original matching pictorial boards. 404 + 609, (1) + 512 + 510 pages including 50 + 83 + 154 plates, mostly of coins, plus hundreds of additional illustrations, often of coins. Fine.

\$200

The four volumes comprising the Paris, Berlin and Vienna collections. An extraordinary effort, absolutely essential for Sasanian coins. The first volume covers Ardashir I through Shapur I; the second covers Hormizd I through Hormizd II; and the third volume (in two parts) covers Shapur II through Kavad I. Ex TAB Library.

Classic Work on Athenian Silver

148 Thompson, Margaret. THE NEW STYLE SILVER COINAGE OF ATHENS. New York: ANS, 1961. Two volumes. 4to, original matching red cloth, gilt. Frontispiece, (8), 747 pages; (8) pages, 226 fine plates of coins, 2 folding. Fine.

\$200

An exceptional work, still of considerable importance. Established a new chronology for these coins that was far more accurate and detailed than had previously existed. *Numismatic Studies* No. 10. Clain-Stefanelli 2529*. Daehn 4194. Ex TAB Library.

Run of Tkalec Sale Catalogues

149 Tkalec & Rauch, Münzauktion / A. Tkalec AG. AUCTION CATALOGUES. Zürich, 1986–2013. Twenty-six well-illustrated catalogues, dated as follows: 14.–15. April 1986; 16.–17. November 1987; 25.–26. April 1989; 26. März 1991; 23. Oktober 1992; 28. Oktober 1994; 25. Oktober 1996; 23. Oktober 1998; 29. Februar 2000; 19. Februar 2001; 18. Februar 2002; 24. Oktober 2003; 9. Mai 2005; 7. Mai 2006; 28. Februar 2007; 22. April 2007; 26. Oktober 2007; 29. Februar 2008; 8. September 2008; 7. Mai 2009; 17. Mai 2010; 9. Mai 2011; 27. Oktober 2011; 29. Februar 2012; 28. Februar 2013; and 22. Oktober 2013. 4to, seven in original pictorial boards, the rest in pictorial card covers. Generally fine or nearly so.

\$150

A notable series of auction catalogues, primarily of ancient and medieval coins. Ex TAB Library.



Coinage of Julius Marinus

150 Tôchon d'Annecy, Joseph François. *MÉMOIRE SUR LES MÉDAILLES DE MARINUS, FRAPPÉES À PHILIPPOPOLIS*. Paris: L.G. Michaud, 1817. 4to, original printed paper covers. Printed title page with engraved depiction of both sides of a coin of Marinus; 58, (4) pages; 1 text engraving; 1 full-page engraving depicting *Médailles de Marinus, de l'Empereur Philippe et de sa Famille*. Spine wear; marginal discoloration; very good. **\$100** Examines the coins issued in the name of Julius Marinus, the deified father of Philip the Arab. Leitzmann 140.

Hardcover Wealth of the Ancient World

151 Tompkins, Janice Firth [general editor]. *WEALTH OF THE ANCIENT WORLD: THE NELSON BUNKER HUNT AND WILLIAM HERBERT HUNT COLLECTIONS*. Fort Worth: Kimball Art Museum, 1983. 4to, original cream-colored linen, impressed with silver lettering; color jacket. 329, (1) pages; well illustrated in color and monochrome. New, still in shrink-wrap. **\$100** A rarely seen hardcover version of this beautifully illustrated catalogue. Ex TAB Library.

Martin Jessop Price Festschrift

152 Tzamalis, A.P. [editor]. *MNHMH MARTIN JESSOP PRICE*. Athens: Hellenic Numismatic Society, 1996. 4to, original orange cloth, gilt. Color frontispiece portrait; 357, (1) pages; numerous text illustrations, several in color; errata slip laid in. Text in Greek and English. Near fine. **\$100** An impressive festschrift published in memory of Martin Jessop Price, the great British specialist in Greek numismatics whose early death affected many. Infrequently seen. Daehn 133.

The Roberto Russo Festschrift

153 van Alfen, Peter G., and Richard B. Witschonke [editors]. *ESSAYS IN HONOR OF ROBERTO RUSSO*. Zürich: NAC, 2013. 4to, original maroon cloth, gilt; jacket. xviii, 408 pages; illustrated. Fine. **\$120** A festschrift in honor of Russo, with 19 papers on Greek, Roman and medieval coinage. Most important for Andrew McCabe's 174-page treatise "The Anonymous Struck Bronze Coinage of the Roman Republic: A Provisional Arrangement." Ex TAB Library.

Roman Provincial Coins of the Balkans

154 Varbanov, Ivan. *ГРЪЦКИ ИМПЕРАТОРСКИ МОНЕТИ*. Bourgas, 2002. Four volumes, complete. 8vo, original matching blue leatherette, gilt; jackets. 1480 pages; well illustrated. Fine. **\$120** A complete set of these important modern references on Roman Provincial (Greek Imperial) types struck in Balkan mints.



Coinage of Hispania

155 Vives y Escudero, Antonio. *LA MONEDA HISPÁNICA*. Madrid: Real Academia de la Historia, 1924–1926. Two volumes: text and plate portfolio. Small 4to, contemporary matching red half calf, gilt; spines with five raised bands, ruled and lettered in gilt. (4), cxcvi, (4), 74, (2) + 200 + 135, (1) + 148 + (2), 13, (1) pages; text illustrations; 173 fine plates of coins. Bindings rubbed and a bit worn, with a spring signature or two; plates housed loose, as issued, in matching portfolio. Very good. **\$450** A scarce and important work on the Celtic coins of the Iberian peninsula. The plates are of far better quality than those found in the reprint. Clain-Stefanelli 5095*. Daehn 2165. Grierson 99.

Waddington on Asia Minor

156 Waddington, W.H., E. Babelon and Th. Reinach. *RECUEIL GÉNÉRAL DES MONNAIES GRECQUES D'ASIE MINEURE. TOME PREMIER. PREMIER-QUATRIÈME FASCICULE*. Hildesheim/New York, 1976 reprint. 4to, original blue cloth, gilt. (8), iv, 640, (4) plus *bis* pages; 111 + 15 plates of coins. Fine. **\$100** A useful reprint of this important work, first published in 1904. Clain-Stefanelli 2600*. Grierson 57. Ex TAB library.

Classic Study of the Ziggurat at Ur

157 Woolley, Leonard. *THE ZIGGURAT AND ITS SURROUNDINGS*. New York, 1939. Large 4to, original russet cloth and printed boards. Frontispiece, xiv, 150 pages; 88 plates, many of them folding. Previous owner's stamp on flyleaf; corner bumps; near fine. **\$300** Based on Sir Leonard Woolley's 12 seasons spent excavating at Tell el-Muqayyar, the site of the ancient city of Ur. Publications of the Joint Expedition of the British Museum and of the University Museum, University of Pennsylvania, Philadelphia to Mesopotamia. *Ur Excavations* Volume V.

Zograph on the Black Sea

158 Zograph, A.N. *ANCIENT COINAGE. PART I: THE GENERAL PROBLEMS OF ANCIENT NUMISMATICS. PART II: THE ANCIENT COINS OF THE NORTHERN BLACK SEA LITTORAL*. Oxford, 1977. Two volumes. 4to, original printed card covers. (4), 169, (5) + (6), 171–421, (5) pages; 50 plates of coins. Spines and covers taped and worn; very good. **\$100** The first English edition of Zograph's standard work. Scarce. *BAR Supplementary Series* 33 (i) and (ii). Daehn 266.

MEDIEVAL & MODERN FOREIGN NUMISMATICS

Exceptionally Illustrated in Color

159 Administration des Monnaies et Médailles. DÉCORATIONS OFFICIELLES FRANÇAISES. Paris, 1956. Edited by Yves Malécot. Small folio [32.5 by 25.5 cm], original cream cloth, lettered in blue with embossed central device in silver. 291, (3) pages; handsomely illustrated on 54 plates, many of them in color. Cloth with minor discoloration. [with] ADDITIF. Paris, 1967. Small folio [31 by 24.5 cm], original printed card covers. 27, (1) pages, with 6 color plates. Very good or better. **\$100**
A sumptuously produced work. Mulder & Purves 669-1 and 669-2 (listed under Malécot). Suetens 554. Ex Richard E. Margolis Library.

Akerman's 1840 Numismatic Manual

160 Akerman, John Yonge. A NUMISMATIC MANUAL. London: Taylor & Walton, 1840. 8vo, contemporary green half calf; spine with four raised bands, ruled and decorated in gilt; dark red spine label lettered in gilt. xiv, (2), 420 pages; text illustrations; 17 lithographic and engraved plates. Binding rubbed at extremities, but sound and with contemporary charm. **\$100**
A readily available, but still rather interesting, early numismatic guidebook for collectors.

Schiller Medals

161 Andorfer, Karl. SCHILLER-MEDAILLEN. ZUR FEIER DES 100. TODESTAGES DES DICHTERFÜRSTEN. Wien, 1905. 8vo, later green leatherette, gilt. 44, (2) pages, text illustrations. Fine. **\$100**
Scarce: the first copy we've encountered in many years. Ex Richard E. Margolis Library.

Well-Illustrated Work on Historical Medals

162 Babelon, Jean. LA MÉDAILLE ET LES MÉDAILLEURS. Paris, 1927. 8vo, original pictorial card covers. 234, (4) pages; 32 very fine plates. Covers dusty and a bit worn; near fine. **\$100**
A most useful and handsomely illustrated introduction to historical medals, from the Renaissance to modern times. Clain-Stefanelli 14091. Ex Richard E. Margolis Library.

Resources on the Château de Chaumont

163 Baillargé, Alphonse, and Vte. Joseph Walsh. LES CHÂTEAUX DE BLOIS RESTAURÉ, CHAMBORD, CHAUMONT, AMBOISE ET CHENONCEAUX. Blois: Mme. Prévost, 1852. 16mo, original printed card covers. (2), 47, (1), 96, 44 pages; 3 lithographic plates depicting castles. Light foxing; very good. [with] Bosseboeuf, L. LE CHÂTEAU DE CHAUMONT SUR LOIRE. Tours: Éditions Alfred Mame, 1906. 4to, original printed card covers. xvi, 575, (1) pages; 270 text figures; 15 plates.

Front cover taped. Very good.

\$150

Two scarce publications relating to the Château de Chaumont, where Jean-Baptiste Nini created his terra cotta medallions of Franklin and other well-known figures of the day. The first work is cited in the bibliography to Richard Margolis's *Benjamin Franklin in Terra Cotta*: "Vicomte Joseph Walsh, although not actually naming Nini, stated. 'M. Le Ray ... avait fait venir un artiste distingué; on a de lui, en terre de Chaumont, des médaillons de Fracklin [sic], de Louis XIV et de Marie-Antoinette, encore recherchés aujourd'hui.'" The second volume illustrates a number of medals associated with the castle and its people. Ex Richard E. Margolis Library.

Richard Margolis's Annotated Copy

164 Baudey, J.-C. MONNAIES ANCIENNES IMPORTANT ENSEMBLE DE LA RÉVOLUTION ET DE L'EMPIRE. Lyon, 5 décembre 1975. Tall 4to, later red cloth, gilt. 23 pages; 387 lots; 17 plates. Printed estimates list bound in; hand-priced in pencil. Binder's leaves added for bulk. Fine. **\$100**
Richard Margolis's hand-priced copy of this notable sale of Revolutionary and Napoleonic-era material. Ex Richard E. Margolis Library.

Dutch Family Medals

165 Bemolt van Loghum Slaterus, A. J. NEDERLANDSE FAMILIEPENNINGEN TOT 1813. De Walburg Pers Zutphen: Koninklijk Nederlandsch Genootschap, 1981. 8vo, original blue leatherette, gilt. 253, (3) pages; 56 plates. Fine. **\$100**
Infrequently encountered. Ex Richard E. Margolis Library.

Welzl von Wellenheim's Medieval & Modern Coins

166 Bermann, J.B., & Sohn. VERZEICHNISS DER MÜNZ- UND MEDAILLEN-SAMMLUNG DES KAISERL. KÖNIGL. HOFRATHES UND MITGLIEDES MEHRERER GELEHRTEN GESELLSCHAFTEN, HERRN LEOPOLD WELZL VON WELLENHEIM. II. BAND. I.-II. ABTHEILUNG. / CATALOGUE DE LA GRANDE COLLECTION DE MONNAIES ET MÉDAILLES DE MR. LÉOPOLD WELZL DE WELLENHEIM. VOLUME II. TOMES I-II. Wien: In Commission bei J.B. Bermann & Sohn, 1844-1845 (sale dates: 10. Februar 1845 und folgende Tage + 7. Jänner 1846 und folgende Tage.). Two volumes, bound in one. Thick 8vo modern green cloth, gilt. (14), 604, (2), 47, (1) + (6), 805, (3) pages; 12,428 + 861 + 15,818 + 9 lots. Some foxing and browning; a bit musty. Very good or so. **\$100**
A remarkable collection, with this part including over 29,000 lots of coins and medals (a first volume, listing some 17,000 ancient coins, is not here present). The present volumes are largely devoted to an astonishing variety of medieval and modern European coins and medals, and an excellent numismatic library. Scarce and important, particularly so for medals. Clain-Stefanelli 14141*. Ex Richard E. Margolis Library.

Useful Guidebook on Medals

167 Bernhart, Max. *MEDAILLEN UND PLAKETTEN*. Berlin: Richard Carl Schmidt & Co., 1911. Small 8vo, original cloth-backed gray boards lettered in white and with embossed impressions of medals on front cover. viii, 180, (20) pages; illustrated. Cracked hinged; very good. **\$100**

An excellent exposition on historical medals, featuring an indispensable bibliography and list of "Signaturen." Very scarce. Kolbe 162.

Extensive Study of the Coins of Brittany

168 Bigot, Alexis. *ESSAI SUR LES MONNAIES DU ROYAUME ET DUCHÉ DE BRETAGNE*. Paris: Rollin, Antiquaire, 1857. 8vo, original printed paper covers. (4), iv, (2), 422, (2) pages; 40 lithographic plates of coins. Unopened; near fine. **\$150**

Includes significant historical appendices in addition to cataloguing 1482 coins issued between the Merovingian period and the 16th century. Very scarce. Clain-Stefanelli 6363. Engel & Serrure 591.

Major Work on Benedetto Pistrucci

169 Birosi Stefanelli, Lucia Pirzio. *I MODELLI IN CERA DI BENEDETTO PISTRUCCI*. Roma: Istituto Poligrafico dello Stato, 1989. Two volumes. 4to, original matching red cloth, gilt; jackets; housed in original slipcase. ix, (1), 279, (3) + 263, (11) pages; very well-illustrated, mostly in color. Fine. **\$100**

A well-produced and beautifully illustrated catalogue of this medallist's exceptional wax models. Supplementi del *Bollettino d'arte e del Bollettino di numismatica*. Ex Richard E. Margolis Library.

Italian Renaissance & Baroque Medals

170 Börner, Lore. *DIE ITALIENISCHEN MEDAILLEN DER RENAISSANCE UND DES BAROCK*. Berlin: Mann, 1997. 4to, original printed green cloth. 458 pages; 152 plates. Fine. **\$100**

A very well-illustrated descriptive catalogue. *Berliner Numismatische Forschungen*, Neue Folge, Band 5. Ex Richard E. Margolis Library.



Georg Ulex's Presentation Copy

171 Bom, G. Theod., & Zoon. *BEREDENERDE CATALOGUS DER NEDERLANDSCHE MUNTEN GESLAGEN SE-*

DERT DE PACIFICATIE VAN GENT IN 1576, UITMAKENDE HET MUNKABINET VAN WIJLEN DEN HEER W.E. RIJNBENDE, ASSURADEUR TE AMSTERDAM. Amsterdam, 18 Augustus 1890 en volgende dagen. Square 8vo, later black cloth and boards, gilt; original printed aper covers bound in. xii, 223, (1) pages; 2524 lots. Some spotting throughout; near fine. **\$100**

A presentation copy, printed on special paper, of this significant (and very scarce) sale of early modern Dutch material. Inscribed by Adrien Bom to Georg Ulex on the presentation leaf. Ex Richard E. Margolis Library.

Bound Volume of Early Bourgey Sales

172 Bourgey, Etienne. *BOURGEY SALES (1911-1913)*. Spine title cited. Five sales of French and ancient coins, medals and jetons, bound in one volume. Includes: 27-28 novembre 1911 (Chabenat Collection, Part 1); 14-15 décembre 1911 (Chabenat Collection, Part 2—Monnaies grecques et romaines); 3 mai 1912 (Laffon Collection); 5 mai 1913 (Capitaine Collection); and 27-28 octobre 1913 (Collection G.). 4to, later green cloth, gilt; original printed card covers bound in. Fine. **\$100**

Wide-ranging catalogues, three of them including ancient coins. Includes Spring 25, 29 and 30. Ex Richard E. Margolis Library.

Bound Récamier Catalogue

173 Bourgey, Etienne. *COLLECTION RÉCAMIER. MONNAIES ROMAINES, MONNAIES FRANÇAISES, JETONS, MÉDAILLES, SCEAUX, ANTIQUITÉS, SÉRIES LYONNAISES*. Paris, 2-6 mars 1925. 4to, later green cloth, gilt; original printed card covers bound in. (4), 86, (2) pages; 1546 lots; 24 fine plates. Prices realized clipped from newspaper pasted onto flyleaf. Near fine. **\$100**

A bound copy of this notable sale, with partial prices realized as reported in *La Gazette de l'Hôtel Drouot*. Features important Merovingian coins, along with Roman Imperial coins. Clain-Stefanelli 5782. Spring 37. Ex Richard E. Margolis Library.

Babut Collection of French Coins

174 Bourgey, Etienne. *COLLECTION BABUT (Ire PARTIE). MONNAIES FRANÇAISES, GAULOISES, MÉROVINGIENNES, CAROLINGIENNES, CAPÉTIENNES. MONNAIES DE LA RÉVOLUTION ET DE L'EMPIRE*. Paris, 28 mars-1 avril 1927. 4to, contemporary blue quarter calf with mottled boards; spine ruled and lettered in gilt; marbled endpapers. (8), 66, (2) pages; 1209 lots; frontispiece portrait; 15 very fine plates. Near fine. **\$100**

A handsomely bound copy of this scarce and important sale catalogue. Clain-Stefanelli 5179. Grierson 290.

Visit our online store at

numislit.com

to browse even more titles

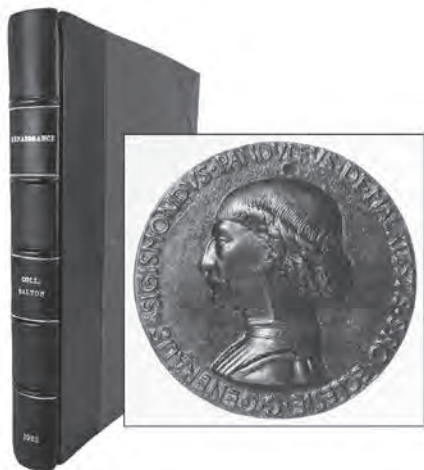

The Salton Collection, Nicely Bound

175 Bowdoin College Museum of Art. **THE SALTON COLLECTION: RENAISSANCE & BAROQUE MEDALS & PLAQUETTES.** Brunswick, 1965. 4to, later black half morocco with blue cloth sides; spine with five raised bands, ruled and lettered in gilt; textured blue endpapers; all page edges speckled blue. Unpaginated; well illustrated. All leaves bound in on hinges. Fine. **\$100**
An attractively bound copy of this notable catalogue. Ex Alain Poinsignon Library.

Rare Brasseux Prefatory Publication

176 Brasseux aîné. **CATALOGUE DES MÉDAILLES DE L'HISTOIRE NUMISMATIQUE DE NAPOLÉON, COMME GÉNÉRAL, CONSUL ET EMPEREUR, FRAPPÉES A LA MONNAIE DE PARIS, DEPUIS LA BATAILLE DE MONTENOTTE, EN 1796, JUSQU'À NOS JOURS.** Paris: En vente, chez Brasseux aîné, graveur du roi, éditeur, Palais-Royal, No 47, Galerie Montpensier, 1840. 8vo, self-covered. (8), 8 pages. Pencil markings on covers; very good. **\$100**

The introductory matter, including checklist descriptions, of this series of 110 Napoleonic medals struck at the Paris Mint. It is also found used as a preface to the fully illustrated version of the same title, which comes with 110 lithographic plates not here present. This version was presumably issued as a marketing tool to generate orders of the main work and the medals themselves. Ex Richard E. Margolis Library.

Breton's Two Classics

177 Breton, P.N. **HISTOIRE ILLUSTRÉE DES MONNAIES ET JETONS DU CANADA / ILLUSTRATED HISTORY OF COINS AND TOKENS RELATING TO CANADA.** Montreal, 1894. 4to, original printed paper covers. 239, (1) pages; illustrated throughout, with tissue-guarded portrait plates. Covers chipped; text unopened and near fine. [with] Breton, P.N. **POPULAR ILLUSTRATED GUIDE TO CANADIAN COINS, MEDALS, & . / GUIDE POPULAIRE ILLUSTRÉ DES MONNAIES ET MÉDAILLES CANADIENNES, ETC. ETC.** Montreal, 1912. 8vo, later black and green cloth. 195, (1) pages; text illustrations and portraits. Very good or so. **\$100**

Both of Breton's classic works on early Canadian numismatics. Clain-Stefanelli 8517* and 8518*. Grierson 219. CNB page 56. Ex Roger Persichilli Library.

Catalogues of British Colonial Coins

178 [British Colonial Numismatics] Glendining & Co. **THE PRIDMORE COLLECTION OF THE COINS OF THE BRITISH COMMONWEALTH OF NATIONS. PART I: THE WEST INDIES, CANADA, EUROPE, AFRICA.** [with] **PART II: ASIAN TERRITORIES, INDIA, AUSTRALASIA.** [with] **PART III: THE UNIFORM COINAGE OF INDIA.** London, 1981–1983. [with] Spink. **THE JERRY REMICK COLLECTION OF COLONIAL AND BRITISH COMMONWEALTH COINS. PART I: AUSTRALIA AND ASIA.** [with] **PART II: EUROPE, AFRICA & THE INDIAN OCEAN.** [with] **PART III: WEST INDIES, CENTRAL & S. AMERICA AND CANADA.** London, 2006–2007. [with] Spink. **THE IMPORTANT R.J. FORD COLLECTION OF BRITISH COLONIAL COINS OF EUROPE AND THE WEST INDIES. (PART 1).** [with] **THE R.J. FORD COLLECTION (PART 2) OF BRITISH COLONIAL COINS OF AFRICA AND THE INDIAN OCEAN.** London, 1990–1991. All 8vo, original printed card covers. Prices realized lists for all laid in. Fine. **\$120**

Eight significant sale catalogues offering British colonial coins. Ex Richard E. Margolis Library.

Medals of the Houses of Welf

179 Brockmann, Günther. **DIE MEDAILLEN DER WELFEN. BAND 1: LINIE WOLFENBÜTTEL. BAND 2: LINIE LÜNEBURG / HANNOVER. DIE GESCHICHTE DER WELFEN IM SPIEGEL IHRER MEDAILLEN.** Köln, 1985 & 1987. Two volumes. 8vo, original matching pictorial boards; jackets. 414 + 356 pages; illustrated. *Nachträge zu Band 1* laid in. Near fine. **\$100**

A detailed catalogue of these issues, extending from the 16th to the 20th century. Modesti 314. Ex Richard E. Margolis Library.

British Historical Medals

180 Brown, Laurence. **A CATALOGUE OF BRITISH HISTORICAL MEDALS, 1760–1960. VOL. I: THE ACCESSION OF GEORGE III TO THE DEATH OF WILLIAM IV.** London: Seaby, 1980. Tall 4to, original blue boards, gilt; jacket. xxvi, 469, (1) pages; illustrated throughout. Very good. [with] Brown, Laurence. **A CATALOGUE OF BRITISH HISTORICAL MEDALS, 1760–1960. VOL. II: THE REIGN OF QUEEN VICTORIA.** London: Seaby, 1987. Tall 4to, original blue cloth, gilt; jacket. xxiv, 516 pages; illustrated throughout. Very good or better. **\$120**

The volumes of this very important reference covering the 18th and 19th centuries, including a number of medals of North American relevance. Ex Richard E. Margolis Library.

The David Salomons Collections

181 Brown, M.D. **DAVID SALOMONS HOUSE. CATALOGUE OF MEDALS RELATING TO THE HISTORY OF TRANSPORT.** Privately Printed, 1968. Frontispiece medal plate; ix, (1), 37, (1) pages; 5 additional plates of medals. [with] Brown, M.D. **DAVID SALOMONS HOUSE. CATALOGUE OF MEMENTOS.** Privately Printed, 1968. x, 84, (2) pages; 11 plates. [with] Brown, Malcolm. **DAVID SALOMONS HOUSE. CATALOGUE OF BALLOONIANA.** Privately Printed, 1971. Frontispiece; xiii, (1), 37, (1) pages; 5 additional plates, one of

them double-sided. Three volumes. All 8vo, original matching blue cloth, gilt. Fine. **\$100**

Three highly interesting specialized catalogues focusing on the collections formed by Salomons on medals and other memorabilia concerning railways, hot air balloons, and other forms of transportation. While the first volume is devoted entirely to medals, the other two volumes include at least some medals. Ex Richard E. Margolis Library.

Buck & Meier on Hannover

182 Buck, Heinrich, and Ortwin Meier. *DIE MÜNZEN DER STADT HANNOVER*. Hannover, 1935. Folio, contemporary green half morocco with marbled sides; spine ruled and lettered in gilt. viii, 243 pages; folding genealogical table; 2 maps; text illustrations; 8 fine plates of coins. Marginal damp-staining; very good. **\$150**

The standard work. Rare. Clain-Stefanelli 9374*. Grierson 148. Ex Roger Tobin Library (Kolbe & Fanning Sale 136, lot 38).

Buck & Bahrfeldt on Hildesheim

183 Buck, Heinrich, and Max von Bahrfeldt. *DIE MÜNZEN DER STADT HILDESHEIM*. Hildesheim & Leipzig, 1937. Folio, later tan cloth-backed boards. xi, 361, (3) pages; tables; occasional text illustrations; 12 very fine plates. Title written on spine; near fine. **\$150**

Still standard. Band II of *Die Münzen des Bistums und der Stadt Hildesheim*. Clain-Stefanelli 9389. Ex Roger Tobin Library (Kolbe & Fanning Sale 136, lot 39).

Bucknill on the Dutch East Indies

184 Bucknill, Sir John. *THE COINS OF THE DUTCH EAST INDIES: AN INTRODUCTION TO THE STUDY OF THE SERIES*. London, 1931. 8vo, green cloth, gilt; original printed card covers bound in. xii, 291, (5) pages; text illustrations. Near fine. **\$100**

Still a standard work. Clain-Stefanelli 8815. Grierson 222. Ex Katen Library with stamps.

Claude Burgan Sale Catalogues

185 Burgan, Claude. *PRICE LISTS 1976–1981*. Spine title cited. Five illustrated catalogues bound together, including: Liste No. 2 (octobre 1976); No. 7 (janvier 1979); No. 8 (1979); No. 9 (septembre 1979); and No. 10 (septembre 1981). 8vo, later green cloth, gilt; original printed card covers bound in. Fine. **\$100**

Useful catalogues, infrequently offered. Ex Richard E. Margolis Library.

Burzio's Dictionary of Spanish-American Coins

186 Burzio, Humberto F. *DICCIONARIO DE LA MONEDA HISPANOAMERICANA*. Santiago de Chile, 1956–1958. Three volumes, complete. 4to, original matching printed card covers. xix, (1), 327, (3); 453, (5); (6) pages; 116 plates. Near fine. **\$100**

A very useful work. Clain-Stefanelli 11462*: "an exhaustive study of the Spanish-American coinage conveniently arranged in alphabetical order by entries." Ferrari * 13: "Se trata de una obra fundamental que constituye, excediendo su carácter de nomenclator, un verdadero inventario del estado de la numismática hispanoamericana el momento de su aparición." Grierson 213: "un ouvrage de référence essentiel." Ex Richard E. Margolis Library.

Canadian Banking Journal

187 Canadian Bankers' Association. *JOURNAL OF THE CANADIAN BANKERS' ASSOCIATION / CANADIAN BANKER*. Volumes I–CII (1893–1995), complete for the period covered. Varying formats (8vo and 4to), the set is bound in several styles through the 1980 volume: most of the first 49 volumes are attractively bound in half calf with five raised spine bands; most of the remaining volumes are bound in cloth, with most volumes after Vol. 84 in their original paper covers. A handful of the bindings are defective, but most are sound and in nice condition. Bound indices for Volumes 1–30 and 31–71 included, as well as original indices for Volumes 72–84. Overall condition of the set is very good to fine. **\$750**

A nearly complete run of this very scarce publication, being the first 102 volumes published. The Canadian Bankers' Association was founded in Montreal on December 17, 1891. The first issue of the *Journal of the Canadian Bankers' Association* was published in September 1894. In 1936, the name of the journal was changed to the *Canadian Banker*, under which name it was published until 2000, at which time it ceased publication. A number of articles of numismatic interest were published in its pages over the years, including many works by Adam Shortt on Canadian currency and banking. Significant runs are rarely encountered, and this would appear to be one of only a few essentially complete sets known (the final volumes should be relatively easy to fill in). Ex Charles Moore Library (David Sklow Sale 16, lot 340); ex William A. Burd Library.

Hardcover Christensen Catalogues

188 Christensen, Henry. *SPECIAL EDITION AUCTION SALES*. Seven hardcover catalogues, dated: February 21, 1958 (Silver Dollars of Independent Mexico); November 28–29, 1961 (Lipno Collection of Gold Coins); May 12, 1962 (San Cristobal Collection); May 8, 1963 (Rosholm Collection); December 6, 1963 (Prober-Noronha and Babbitt Collections); April 15–16, 1964 (Silver Dollars of Latin America); and June 30, 1964. 8vo, original maroon pebbled cloth; original printed card covers bound in. Prices realized lists bound in. Covers a little dusty; near fine. **\$120**

Rarely encountered special editions of Christensen's catalogues, an indispensable source of information for collectors and dealers specializing in Spanish and Latin American coins and medals (the Rosholm collection features Scandinavian coin). Ex Richard E. Margolis Library.

Scarce Ciani Sale of Gold Coins

189 Ciani, L. *COLLECTION DE M. B... MONNAIES EN OR*. Paris, 15 février 1937. 4to, later black cloth with blue and black mottled boards, gilt; decorative endpapers. 15, (1) pages; 224 lots; 6 fine plates. Hand-priced in pencil; prices realized list laid in. Near fine. **\$100**

Scarce. The sale opens with a few ancient gold coins, but the focus is on European gold, most particularly of France and Germany, though some other material is included (including three notable gold coins of Annam toward the end of the sale). Ex Richard E. Margolis Library.

All lots illustrated in full color at
bid.numislit.com

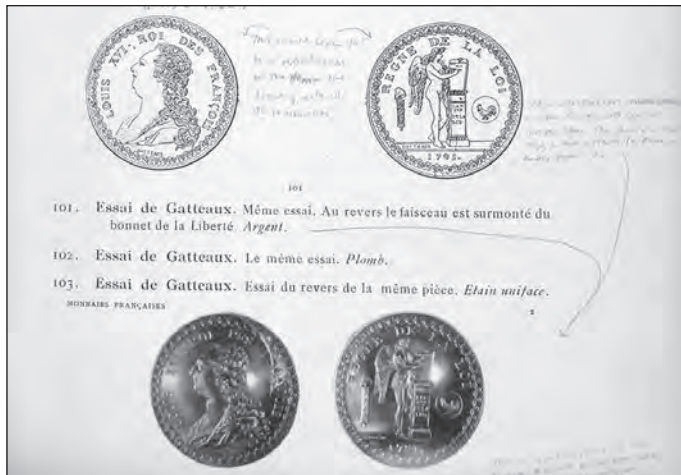

Charles Florange's Copy, Heavily Annotated by Richard Margolis

190 Ciani, P. *LES MONNAIES FRANÇAISES DE LA RÉVOLUTION À LA FIN DU PREMIER EMPIRE, 1789 À 1815*. Paris, 1931. Tall 8vo, later green half morocco; spine lettered in gilt; original printed paper covers bound in. (2), viii, (2), 168 pages; illustrated; large folding table of French mints laid in. Heavily annotated throughout in pencil by Richard Margolis, with various inserts (notes, photocopies, photographs) laid in and occasionally pasted in. Inscribed to Charles Florange by Pio Ciani on the half title. One signature sprung; else near fine. **\$300**

A fantastic copy of this notable work: inscribed to Charles Florange by the author, Pio Ciani, it was later in the library of Richard Margolis, who for many years used it as his notation copy, in which he recorded new discoveries, made emendations and corrections, and entered his own thoughts on the subject (a note written toward the front of the volume indicates that some of the notes were made long ago and had not necessarily been revised). The inserts provide photographic representations of important pieces, photocopies from catalogues, and original clippings. The 1931 Ciani volume is a significant publication on the subject, and is much scarcer than the similar works on earlier French coinage written by his brother Louis. Unlisted in Clain-Stefanelli. Ex Charles Florange Library; ex Richard E. Margolis Library.

Clain-Stefanelli's Masterful Bibliography

191 Clain-Stefanelli, E.E. *NUMISMATIC BIBLIOGRAPHY*. München: Battenberg, 1985. Thick 12mo, original brown leatherette-backed linen, lettered in brown and gilt. xxii, 1848 pages; 18,311 listings; 6 indexes. Fine. **\$100**
By far the most comprehensive modern numismatic bibliography.

Scott Cordry Islamic Catalogues

192 Cordry, Scott E. *COINS OF THE WORLD*. Titles vary. Forty-two fixed price lists, being Catalogue Nos. 37–90 (1976–1993), lacking only Nos. 43, 44, 76, 77, 80–83 and 85–88. All 8vo, self-covered as issued. [with] Cordry, Scott E. *MAIL BID AUCTIONS*. Auction Nos. 1–10, complete (1981–1989). All 8vo, original printed card covers. Fine. **\$100**
A well-produced series of illustrated fixed price and auction catalogues, of considerable use particularly for Islamic coins. Rarely encountered in such numbers.

Monographs on Canadian Tokens

193 Courteau, Eugene G. *THE CANADIAN BOUQUET-SOUS*. St-Jacques, 1908. 8vo, original printed paper covers. 20, (6) pages; 4 plates. Covers a bit worn. Near fine. [with] Courteau, Eugene G. *THE COINS AND TOKENS OF NOVA SCOTIA*. St. Jacques, Que., 1910. Small 4to, original cloth-backed printed card covers. 30, (2) pages; 7 photographic plates. Near fine. [with] Courteau, Eugene G. *MONNAIES DE CUIVRE ÉMISES PAR LA BANQUE DE MONTRÉAL / THE COPPER TOKENS OF THE BANK OF MONTREAL*. St. Jacques, 1919. Small 4to, original cloth-backed printed card covers. (4), 25, (1) pages; illustrated. Fine. [with] Courteau, Eugene G. *THE ST. GEORGE COPPER TOKENS OF THE BANK OF UPPER CANADA*. St.-Jacques, 1934. Small 4to, original cloth-backed printed card covers. 32 pages. Fine. **\$100**

Classic works by one of the most important Canadian numismatists of the early 20th century, generally offering a finer distillation of each series than that given by Breton. The photographic plates in the Nova Scotia reference are very well executed. Ex Roger Persichilli Library.

The Frankish & Saxon Kings

194 Dannenberg, Hermann. *DIE DEUTSCHEN MÜNZEN DER SÄCHSISCHEN UND FRÄNKISCHEN KAISERZEIT*. Aalen, 1967 reprint. Four volumes, complete. 4to, original gray cloth, gilt. 1019, (1) + (2), 109, (1) pages, plus preliminaries; text illustrations; maps; 121 + 15 plates of coins. Near fine. **\$200**
Indispensable. Clain-Stefanelli 6500*.

Davenport on Talers, Crowns, &c.

195 Davenport, John S. *WORLD CROWNS AND TALERS*. A complete set of the nine main illustrated volumes:

- 1: **EUROPEAN CROWNS AND TALERS SINCE 1800**. London, 1964 second (final) edition.
- 2: **EUROPEAN CROWNS 1700–1800**. London, 1964 second edition.
- 3: **GERMAN TALERS 1700–1800**. London, 1965 second edition.
- 4: **EUROPEAN CROWNS 1600–1700**. Galesburg, 1974 (only) edition.
- 5: **GERMAN CHURCH AND CITY TALERS 1600–1700**. Galesburg, 1975 second (final) edition.
- 6: **GERMAN SECULAR TALERS 1600–1700**. Frankfurt am Main, 1976 (only) edition.
- 7: **EUROPEAN CROWNS 1484–1600**. Frankfurt am Main, 1985 second (final) edition.
- 8: **GERMAN TALERS 1500–1600**. Frankfurt am Main, 1979 (only) edition.
- 9: **THE DOLLARS OF AFRICA, ASIA AND OCEANIA**. Galesburg, 1969 only edition.

All 8vo, original cloth or boards, as published. Mostly fine, with fourth volume worn and heavily annotated (see comments). **\$500**
The still-indispensable standard references for these fascinating series. Most of the above are fine copies, with the notable exception of the desirable volume on *European Crowns 1600–1700*, which is Steve Eyer's heavily annotated volume, in which he attempted to record pricing information for many issues in several grade levels. Ex TAB Library.

German Talers

196 Davenport, John S. GERMAN TALERS 1700–1800. London, 1965 second edition. 8vo, original red leatherette lettered in silver. 416 pages; illustrated. Valuation list laid in. Near fine. [with] GERMAN CHURCH AND CITY TALERS 1600–1700. Galesburg, 1975 second (final) edition. 8vo, original black leatherette lettered in silver. 351, (1) pages; illustrated. Fine. [with] GERMAN SECULAR TALERS 1600–1700. Frankfurt am Main, 1976 (only) edition. 8vo, original gray leatherette lettered in silver. 588, (4) pages; illustrated. Supplemental plate laid in. Fine. **\$100**
Still-indispensable standard references for German talers.

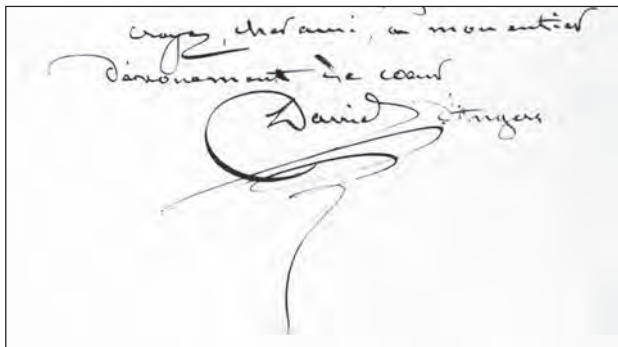

Letter from David d'Angers

197 David, Pierre-Jean [David d'Angers]. HANDWRITTEN LETTER, SIGNED, DATED 5 FÉVRIER 1851. Written in ink on one side [11 by 17 cm] of a sheet of folded notepaper. Folded for mailing; early ink stamp with ink notation by A. Juncker. Fine. **\$250**

A brief note from this famous artist, reading: "Je me rendrai avec bien du plaisir à l'aimable invitation que veut bien me faire, mon cher et très honorable collègue. / Croyez, cher ami, à mon entier dévouement de coeur, David d'Angers." While the recipient is unknown, the letter includes a beautifully elaborate signature of David. Pierre-Jean David (1788–1856), known professionally as David d'Angers, was a French sculptor who became particularly appreciated for his portrait medallions, which are avidly collected by numismatists today.

Conder Token Handbook

198 Davisson, Allan. TOKEN CATALOG AND HANDBOOK. 18TH CENTURY TOKENS AS CATALOGUED BY DALTON AND HAMER AND SELECTED OTHER BRITISH TOKENS. Cold Spring, 1991. 8vo, original crimson cloth, gilt. 95, (1) pages; 12 plates of tokens. Signed by author on title page. Flyleaves, title page and table of contents bear embossed stamp of previous owner. Fine. **\$100**

The Special Hardcover Edition of this interesting guide, one of 100 copies numbered by hand (this is copy 59). Includes a useful bibliography.

Bound Versailles Sales

199 De Poplavsky, Georges, and Bernard Poindessault. VERSAILLES AUCTION SALES 1966–1968 (spine title). Six sales bound together. Includes sales: 26–27 novembre 1966 (with price list), 28 mai 1967, 8 octobre 1967, 10 décembre 1967, 17 décembre 1967 and 17 mars 1968. 4to, later brown cloth, gilt; all original printed card covers bound in. Fine. **\$100**
Ex Richard E. Margolis Library.

Belgium & the Belgian Congo

200 Delmonte, A. TARIF DES MONNAIES DE BELGIQUE PÉRIODE 1815–1963 ET DE L'ÉTAT INDEPENDANT DU CONGO ENSUITE CONGO BELGE PÉRIODE 1887–1960 / PRIJSLIJST DER MUNTEN VAN BELGIE PÉRIODE 1815–1963 EN VAN DE ZELFSTANDIGE STAAT CONGO VERVOLGENS BELGISCH CONGO PERIODE 1887–1960. Bruxelles, Automne 1964. 8.5 by 11 inch sheets of duplicated typescript stapled at spine, as issued. 24 leaves plus cover leaf. Very good or so. [with] Morin, François. MONNAIES CONGOLAISES. CATALOGUE. ETAT INDÉPENDANT DU CONGO, CONGO BELGE, TERRITOIRES SOUS MANDAT DU RUANDA-URUNDI, REPUBLIQUE DÉMOCRATIQUE DU CONGO (KINSHASA), RWANDA, BURUNDI, KATANGA. Boom, undated (1971?). 8.5 by 11 inch sheets of duplicated typescript with printed title page and covers, stapled at spine, as issued. (1), 37 leaves. Very good or better. **\$100**
Two scarce publications.

A Major 1848 Catalogue of French Coins

201 Delombardy. CATALOGUE DES MONNAIES FRANÇAISES DE LA COLLECTION DE MM. RIGNAULT. COMPRENANT LES MONNAIES ROYALES ET NATIONALES D'ARGENT DE BILLON ET DE CUIVRE DEPUIS LE XII^e SIÈCLE JUSQU'EN 1848. Paris: Lacrampe & Fertiaux, mai 1848. 8vo, contemporary green quarter calf with mottled sides; spine lettered in gilt. (ii), 106 pages; 896 listings. Very good or better. **\$120**
The scarce catalogue of a major collection, much of which was acquired by the Bibliothèque Nationale and by J. Rousseau. Engel & Serrure 2028: "Les exemplaires en sont très rares aujourd'hui."

Report on Counterfeits of French Revolutionary Assignats

202 Deperrey, G. LE VÉRIFICATEUR EN CHEF DES ASSIGNATS À SES CONCITOYENS: REMARQUES GÉNÉRALES SUR LES FAUX ASSIGNATS. Paris: L'Imprimerie de la veuve Delaguet, 1793. 8vo, self-covered as issued; unstitched. Ink stamp of E. Dewamin on each leaf, with some underlining; light staining. Good or better. **\$120**

Rare and important, being an original document printed by the French Revolutionary government concerning counterfeits of the paper money (assignats) issued by that government. Deperrey provides eight precise laws to guide the detection of counterfeit assignats, most of which involve direct comparison of probably good notes with suspected false ones. Ex Heather Hardin-Hudson Library, previously in the library of Émile Pierre Norbert Dewamin, author of *Cent ans de numismatique française*.

Biography of Matthew Boulton

203 Dickinson, H.W. MATTHEW BOULTON. Cambridge: Cambridge University Press, 1936. 8vo, original salmon cloth, gilt; jacket. xiv, 218, (2) pages; frontispiece; folding plan; text figures; 14 fine plates. Jacket taped and worn; very good. **\$150**
Scarce. Probably the best biography of Boulton, with an important numismatic chapter entitled "Coinage and Soho Mint." Ex Richard E. Margolis Library.

Droulers's Complete Practical Encyclopedia

204 Droulers, Frédéric. *ENCYCLOPÉDIE PRATIQUE DE NUMISMATIQUE ET DE FINANCES ROYALES 1610-1791. TOME I.* Rouen, 1989. 8vo, original pictorial card covers. (1), xviii, 204 pages; illustrated. Printed card covers. Very good. [with] Droulers, Frédéric. *ENCYCLOPÉDIE PRATIQUE D'HISTOIRE NUMISMATIQUE ET MONÉTAIRE ROYALE 1610-1791. TOME II.* Pornic, 1992. 8vo, original pictorial card covers. (1), viii, 307, (11) pages; addenda et corrigenda leaf; illustrated. Near fine. [with] Droulers, Frédéric. *ENCYCLOPÉDIE PRATIQUE D'HISTOIRE NUMISMATIQUE ET MONÉTAIRE ROYALE 1610-1791. TOME III.* Paris, 2005. 8vo, original pictorial boards. 542, (2) pages; illustrated. Inscribed by the author. Handwritten letter from the author to Richard Margolis laid in. Near fine. **\$100**

All three volumes of this extensive reference. Ex Richard E. Margolis Library.

Necessity Coinage of France, Monaco & Colonies

205 Elie, Roland. *MONNAIES DE NECESSITE ET JETONS-MONNAIE. FRANCE, COLONIES, MONACO, 1800-2000.* Neuilly-sur-Seine, 2003. 4to, original orange leatherette, gilt. 632 pages. Near fine. **\$100**

An extensive catalogue. Ex Richard E. Margolis Library.

Illustrations of English Banks

206 English Banks. *TWO HAND-TINTED ENGRAVED PRINTS AND THREE PRINTED ILLUSTRATIONS DEPICTING ENGLISH BANKS.* Includes: 1) *Bank of England, Taken by Permission from a Drawing in Possession of J. Soane, Esqr. Published J. Stratford, 112, Holborn Hill, Jany. 31, 1807, engraved by Warren for Dr. Hughson's Description of London*, handsomely tinted by hand; 2) *Bank of England, Five Pound Note Office*, signed by Gilbert and Melville, with no further information, also handsomely tinted by hand; 3) *Bank of England. To the Governor & Directors of That National Establishment, This Plate Is Respectfully Dedicated*, printed illustration based on engraving by William Tombleson after a drawing by Thomas H. Shepherd, Published March 21, 1827 by Jones & Co., London. Matted within a gilt wood frame. 4) *The London and Middlesex Bank, Finch-Lane, City*, clipped from the Saturday, February 14, 1863 issue of the *Illustrated London News*, published by George C. Leighton; and 5) *2484. Bank of England*, an unidentified clipped illustration. Sizes, including mattes, range from 31 by 24, 5 cm to 22 by 18.5 cm, with the two hand-tinted engravings being of the larger size. Generally fine, with slight wear to matte margins of second. **\$100**

[Sale 159, lot 510]

Includes some attractive renditions. The unframed works have been professionally matted and are ready for framing. Ex Richard E. Margolis Library.

Modern Medals of Nürnberg

207 Erlanger, Herbert Justin. *NÜRNBERGER MEDAILLEN, 1806-1981.* Nürnberg: Germanisches Nationalmuseum, 1985. Two volumes. 4to, original matching silver-printed blue cloth. xxxii, 790 pages; well illustrated. Fine. **\$100**

Infrequently available. Ex Richard E. Margolis Library.

Collected Papers on Iranian Coinage

208 Faghfoury, Mostafa [editor]. *IRANIAN NUMISMATIC STUDIES: A VOLUME IN HONOR OF STEPHEN ALBUM.* Lancaster: CNG, 2017. 4to, original blue cloth, lettered in silver; jacket. (2), xxxvi, 265, (1) pages; illustrated. Fine. **\$100**

A collection of articles on ancient, medieval and modern Iranian coinage compiled as a festschrift in honor of Steve Album, the foremost American scholar of and dealer in Islamic coins. Ex TAB Library.

Modern Study of Hedlinger

209 Felder, Peter. *MEDAILLEUR JOHANN CARL HEDLINGER, 1691-1771. LEBEN UND WERK.* Aarau, 1978. 4to, original blue cloth, gilt; jacket. 304 pages; well illustrated. Housed in original cardboard slipcase. Fine. **\$100**

A well-produced and attractively illustrated work. Clain-Stefanelli 15103. Ex Richard E. Margolis Library.

Medals of the May Revolution

210 Ferrari, Jorge N., José María Gonzales Condé and Horacio A. Sanchez Caballero. *LA REVOLUCIÓN DE MAYO EN LA MEDALLA.* Buenos Aires, 1960. Thick 8vo, original printed card covers. 878, (2) pages; illustrated throughout. Covers somewhat worn; dampstain to lower margin causing some sticking to second half. Good. **\$100**

A major work, and rather rare. The authors list nearly 1200 individual medals, with many cross-references and correlations. Clain-Stefanelli 14385. Ex Richard E. Margolis Library.

Paul Bordeaux's Revolutionary & Imperial Series

211 Feuarent Frères. *COLLECTION PAUL BORDEAUX. IIIe PARTIE. MONNAIES ET MÉDAILLES FRANÇAISES ET COLONIALES DEPUIS LE RÉVOLUTION 1789, JUSQU'À NOS JOURS.* Paris, 4-8 mai 1929. 4to, later brown quarter morocco; spine lettered in gilt; original printed card covers bound in. (4), 42 pages; lots 1404-1854; 8 fine plates numbered 20-27, with tissue guards. Fine. **\$100**

An attractively bound copy of this scarce and important sale. Clain-Stefanelli 8978. Grierson 290. Ex Richard E. Margolis Library.

Jean Rousseau's French Feudal Coins

212 Fillon, Benjamin. *COLLECTION JEAN ROUSSEAU. MONNAIES FÉODALES FRANÇAISES.* Paris: Chez M. Rousseau, 1860 / Rollin & Feuarent, 25-28 février 1861. 8vo, original printed paper covers. Tinted engraved frontispiece; title printed in red and black; (6), xxxv, (3), 223, (1) pages; text illustrations; 5 lithographic plates of coins. Original printed prices realized list laid in. Unopened; covers spotted. Near fine. **\$150**

Rare, especially with the prices realized list. A very thorough catalogue of an outstanding collection of French feudal coins, catalogued by Benjamin Fillon (with a lengthy introduction), and then sold at auction by



Rollin & Feuarent using Fillon's catalogue as the auction catalogue. Rousseau published the work and the lithographic plates were based on his own drawings. Engel & Serrure 2561. Leitzmann 119.

The Siege of Antwerp

213 Florange, Ch. *LA SIÈGE D'ANVERS, 1832*. Paris: J. Florange, 1932. 12mo, later tan cloth; red spine label, gilt; original printed card covers bound in. (4), 156 pages; text illustrations, many depicting medals; folding map; 7 plates. Near fine. **\$100**
A rarely offered work. Ex Richard E. Margolis Library.

Jetons of the Faculty of Medicine

214 Florange, Ch. *LES JETONS DES DOYENS DE L'ANCIENNE FACULTÉ DE MÉDECINE DE PARIS, 1636–1793*. Paris: Jules Florange, 1933. 8vo, later quarter green cloth and marbled boards; red spine label, gilt; original printed brown card covers bound in. (4), x, 54, (2) pages; text illustrations. Fine. **\$100**
A scarce publication. Ex Richard E. Margolis Library.

Finely Bound Florange on Shooting Medals

215 Florange, J. *SOUVENIRS NUMISMATIQUES DU TIR FRANÇAIS AVANT 1789*. Paris, 1899. 4to, later brown quarter calf; spine lettered in gilt; original printed paper covers bound in back. (4), xiii, (1), 62 pages; text illustrations; 8 lithographic plates. Fine. **\$200**
A well-preserved copy of this scarce and important work on French archery and shooting medals. Clain-Stefanelli 14519. Ex Phiroze K. Randeria Library, with his engraved Zoroastrian-themed bookplate; ex Richard E. Margolis Library.

The Ferrari Papal Coins

216 Florange, J., and Louis Ciani. *MONNAIES PAPALES ET DE LA MAISON DE SAVOIE DU XVIII^e SIÈCLE A NOS JOURS, PROVENANT DES COLLECTIONS DE FEU PHILIPPE DE FERRARI LA RENOTIÈRE*. Paris, 18–20 décembre 1922. 8vo, original printed card covers. (4), 55 pages; 1012 lots; 13 fine plates. Prices realized list laid in. Spine worn; very good. **\$100**
The collection of Ferrari de la Renotière. Scarce, especially with the price list. Clain-Stefanelli 10386 and 10387. Ex Richard E. Margolis Library.

From the Rollin & Feuarent Library

217 Florange, Jules, and Louis Ciani. *COLLECTION DE MÉDAILLES ARTISTIQUES, FRANÇAISES & ÉTRANGÈRES*. Paris, 15 juin 1923. 4to, original printed card covers. 27, (1) pages; 97 lots; 18 very fine plates. Photocopy of the prices realized list laid in. Some markings on cover; very good. **\$100**
An important sale of Renaissance and later French portrait medals. Ex Rollin & Feuarent Library; ex Richard E. Margolis Library.

Folkes's Classic Compendium on English Coins

218 Folkes, Martin. *ENGLISH COINAGE, SILVER AND GOLD, FAITHFULLY COPIED FROM THE ORIGINALS. SILVER — FROM THE NORMAN CONQUEST TO QUEEN ANNE (740 COINS). GOLD — FROM EDWARD II. TO WILLIAM II. (256 COINS). SUPPLEMENT (207 COINS).*

67 PLATES, WITH 1203 COINS, AND THEIR REVERSES. (London, c. 1863). 4to, later brown quarter calf, gilt; spine with five raised bands, ruled and lettered in gilt; original printed paper cover mounted on front board. (2), 4 pages; 42 + 19 + 6 engraved plates. Untrimmed. Minor spotting; near fine. **\$100**
A well-preserved example of this edition, which is a bit of a bibliographical mystery. To quote Manville, this is "an undated reprinting of the plates from the 1762–3 edition of *Tables of English Silver and Gold Coins* and Ruding's three editions of 1817, 1819 and 1840, preceded by a list of contents (pp. 1–4). Although sometimes dated to the 1870s, this may be a centenary volume." Includes early engraved representations of North American colonial coins. Manville 426.

1702 French Royal Decree on Coinage

219 [France]. *ARREST DU CONSEIL D'ESTAT DU ROY, PORTANT REGLEMENT POUR LES PETITES PIECES JUSQU'AU DERNIER JOUR D'AOUST PROCHAIN*. Du vingt-septième Juin 1702. Single sheet, 20 cm by 29 cm, printed on one side. Housed in a modern black resin frame measuring 26 cm by 36 cm. Minor tears not affecting the text; what appears to be an old tape repair on verso. Near fine. **\$100**
A single-sheet arrêt postponing the date by which old specie had to be converted into new coinage, as required by the King's decree of 14 mars. Ex Richard E. Margolis Library.

Corpus of Byzantine Gold Coins

220 Füeg, Franz. *CORPUS OF THE NOMISMATA FROM ANASTASIUS II TO JOHN I IN CONSTANTINOPLE, 713–976. STRUCTURE OF THE ISSUES. CORPUS OF COIN FINDS. CONTRIBUTION TO THE ICONOGRAPHIC AND MONETARY HISTORY*. Edited by Italo Vecchi. Lancaster and London: CNG, 2007. 4to, original maroon cloth, gilt; jacket. (4), 193, (3) pages; illustrated. CD-ROM containing 7,694 nomismata included. Fine. [with] Füeg, Franz. *CORPUS OF THE NOMISMATA FROM BASIL II TO EUDOCIA 9761067. CORPUS FROM ANASTASIUS II TO JOHN 713-976 WITH ADDENDA; STRUCTURE OF THE ISSUES 9761067; THE CONCAVE/CONVEX HISTAMENA; CONTRIBUTION TO THE ICONOGRAPHIC AND MONETARY HISTORY*. Edited by Italo Vecchi. Lancaster and London: CNG, 2014. 4to, original maroon cloth, gilt; jacket. 161, (1) pages; 52 plates. CD-ROM containing 7,780 nomismata included. New, in shrinkwrap. **\$120**
An important work. Ex TAB Library.

The Julius Collection

221 Gaettens jun., R. *SAMMLUNG JULIUS. FRANZÖSISCHE REVOLUTION: NAPOLEON I. UND SEINE ZEIT. MÉDAILLEN – ORDEN UND EHRENZEICHEN – MÜNZEN. I. TEIL: 1789–1808. II. TEIL: 1809–1815. III. TEIL: PERSONENMÉDAILLEN. MINIATURMÉDAILLEN. FRANZÖSISCHE MÉDAILLEN DES XIX JAHRHUNDERTS*. Heidelberg, 21.–23. April, 14.–15. September, and 16.–17. September 1959. Three catalogues. 4to, original printed card covers. (4), vi, 70 + (4), 66 + 53, (1) pages; 5648 lots; 63 plates. Spine taped on Teil 1, titles written on spines; very good. **\$100**
Clain-Stefanelli 14578 & 9153. Grierson 315. Ex Richard E. Margolis Library.

Napoleonic Medals at Liverpool

222 Gatty, Charles T. LIVERPOOL FREE PUBLIC MUSEUM. CATALOGUE OF MEDIAEVAL & LATER ANTIQUITIES CONTAINED IN THE MAYER MUSEUM, INCLUDING THE MATHER COLLECTION OF MINIATURES AND MEDALS RELATING TO THE BONAPARTE FAMILY. Liverpool: Walmsley, 1883. 4to, later tan cloth, gilt. (2), viii, 108, (6) pages; 851 descriptions, including 148 medals; 20 fine plates, the first serving as a frontispiece. Near fine. **\$100**

An interesting (and rather scarce) catalogue, with very fine plates that unfortunately do not include the medals (the author points the reader to illustrations elsewhere). Ex Richard E. Margolis Library.

French Communion Tokens

223 Gelin, H. LE MÉREAU DANS LES ÉGLISES RÉFORMÉES DE FRANCE ET PLUS PARTICULIÈREMENT DANS CELLES DU POITOU / COMMUNION TOKENS IN THE REFORMED CHURCHES OF FRANCE AND MORE PARTICULARLY IN THOSE OF POITOU. 1977 English translation of the 1891 original. Translated by C.S., M.B. Orr and W.H. Woodside. 4to, later maroon cloth, gilt; original printed card covers bound in. (8), 82 pages; 4 plates. Inscribed to the Kellers by M.B. Orr. Highlighting on a few pages; near fine. **\$100**

Quite rare: No. 49 of only 75 copies printed. Still useful. Clain-Stefanelli 13823. Ex Philip F. Keller, with his bookplate; ex Richard E. Margolis Library.

America & France in the Era of Revolution

224 Girodie, André. LES ÉTATS-UNIS ET LA FRANCE AU XVIII^e SIÈCLE. Paris: Hotel Jean Charpentier, 1929. 12mo, later brown cloth and marbled boards, gilt; original printed card covers bound in. 81, (3) pages; 238 listings; 9 plates. Fine. **\$100**

Catalogue of the Exposition la Société des Amis du Musée National de Blérancourt (Aisne). Scarce. Ex Richard E. Margolis Library.

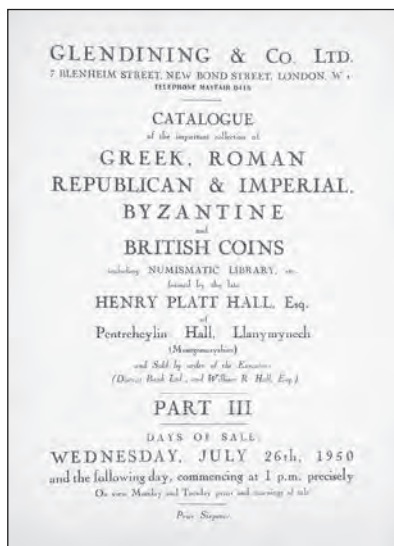

Rare Unissued Henry Platt Hall Part III

225 Glendining & Co. CATALOGUE OF THE IMPORTANT COLLECTION OF GREEK, ROMAN REPUBLICAN & IMPERIAL, BYZANTINE AND BRITISH COINS FORMED

BY THE LATE HENRY PLATT HALL, ESQ. PART III: ENGLISH, SCOTTISH AND ANGLO-GALLIC GOLD AND SILVER, AND IRISH SILVER COINS FROM THE EARLIEST TIMES TO THE PRESENT DAY. ALSO BOOKS ON ENGLISH COINS AND MEDALS, HISTORY, ETC. London, July 26, 1950 [sale not held]. Crown 4to, original printed card covers. 49, (1) pages; 423 lots; 11 fine plates. Near fine. **\$200**

A rare catalogue. Focusing on British coins, the entire collection was purchased *en bloc* by Spink prior to the auction. The sale, therefore, never took place and copies of the catalogue were destroyed prior to dispatch. Clain-Stefanelli 9810. Grierson 297.

Wayte Raymond Collection

226 Glendining & Co. CATALOGUE OF COINS OF THE WORLD IN GOLD & SILVER INCLUDING COINS FROM THE ESTATE OF MR. WAYTE RAYMOND OF AMERICA. 10–11 June 1963. 56 pages; 772 lots; 21 plates. [bound with] CATALOGUE OF COINS OF THE WORLD IN GOLD AND SILVER INCLUDING THE JACSON COLLECTION AND COINS FROM THE ESTATE OF THE LATE MR. WAYTE RAYMOND. London, 16–17 May 1962. 75, (1) pages; 1072 lots; 17 fine plates; price realized printed by each lot. Crown 4to, later blue cloth, gilt; original printed card covers bound in. Near fine. **\$100**

Includes important material from the Raymond collection (some of it deriving from the Ferrari collection), including French gold and silver, Chinese patterns, and an important offering of Indo-Portuguese and Dutch overseas material from another consignment. The second sale is the priced edition. Scarce. Ex Richard E. Margolis Library.

Lyon during the Revolution

227 Gonan, P.-M. LYON EN 1793: PROCÈS-VERBAUX AUTHENTIQUES ET INÉDITS DU COMITÉ DE SURVEILLANCE DE LA SECTION DES DROITS-DE-L'HOMME, L'UNE DES 32 SECTIONS DE CETTE COMMUNE PENDANT LE SIÈGE. Lyon: A. Mothon, 1847. 8vo, later gray cloth-backed marbled boards; spine lettered in gilt; original printed paper covers bound in. Title printed in red and black; 199, (1) pages [pages 137–163 are erroneously skipped in the pagination; title is complete]; 10 lithographic plates, one in color, including three depicting medals and others depicting paper money. Paper covers discolored; occasional minor faults. Very good or better. **\$100**

A rare work focusing on Lyon during this pivotal year of the Revolutionary era. Pays considerable attention to the paper money issues of the period and various medals. Barbier, *Bibliographie de l'histoire de France*, II.1357. Ex Richard E. Margolis Library.

The Heyde Australian Sales

228 Gray, Geoff K. THE GILBERT HEYDE COLLECTION, PARTS I–IV. Sydney, 1973–1974. All four parts of the Gilbert Christoph Heyde Collection of Australiana bound in one volume. 4to, later maroon cloth, gilt; original printed card covers bound in, with all prices realized lists. Fine. **\$100**

An important series of catalogues, written by Colin Pitchfork. Heyde was one of the greatest Australian collectors of the 20th century. Ex Richard E. Margolis Library.

The Shepard Pond Collection

229 Grunthal, Henry, and Numismatic Fine Arts. **THE SHEPARD POND, BOSTON, COLLECTION. NAPOLEONIC COINS AND MEDALS.** New York, June 1, 1948. Extracts: Pages 51–88; lots 1056–2013; 4 fine plates. [*bound with*] Pond, Shepard. **NAPOLEON EMPEROR OF THE REPUBLIC.** Boston, 1942. 10 pages; illustrated. [*bound with*] Raymond, Wayte. **THE SILVER ECUS OF FRANCE 1642–1936.** *The Coin Collector Series Number Three.* New York, 1940. 24 pages; illustrated. 8vo, later green quarter morocco; spine lettered in gilt; original printed card covers bound in. Some glue marks. Near fine. **\$100**

Ex Richard E. Margolis Library.

The Coinage of Ulm

230 Häberle, Adolf. **ULMER MÜNZ- UND GELDGESCHICHTE DES MITTELALTERS.** Ulm: Verlag des Museums der Stadt Ulm, 1935. 120 pages; 8 fine plates depicting 114 coins. [*with*] Häberle, Adolf. **ULMER MÜNZ- UND GELDGESCHICHTE DES XVI.–XIX. JAHRHUNDERTS.** Ulm: Verlag des Museums der Stadt Ulm, 1937. 126, (2) pages; 28 fine plates depicting 112 coins, documents, etc. Small 8vo, original matching printed card covers. Covers a bit worn, with second volume spine taped; spines hand-lettered. Very good or so. **\$120**
Very scarce. Clain-Stefanelli 6735 & 9612.



Portrait Medals of Ethel Harris

231 Harris, Ethel A. C. **PORTRAIT MEDALS OF A GENERATION. MODELLED BY ETHEL A.C. HARRIS. WITH INTRODUCTORY NOTE BY G.F. HILL.** London: Spink & Son, 1928. 4to, original cream cloth printed in red. xv, (1) pages; title printed in red and black; 57 fine plates with descriptive text; (3) page index. Cover somewhat discolored; very good. **\$120**
No. 29 of an edition limited to 250 copies. A highly interesting study. Ex Richard E. Margolis Library.

Finely Bound Hartill on Qing Cash

232 Hartill, David. **QING CASH.** London: Royal Numismatic Society, 2003. 4to, later black half morocco with blue cloth sides; spine with five raised bands, ruled and lettered in gilt; tex-

tured blue endpapers; all page edges speckled blue. 316 pages; 172 plates. Fine. **\$200**

A handsomely bound copy of this important work. From the preface: "The aim of this work is to present a historical catalogue of cash issued by the Qing and the rebels and pretenders of the time." RNS Special Publication No. 37. Ex Alain Poinson Library.

Medals of Ferdinand I & Franz Josef I

233 Hauser, Peter. **KATALOG MEINER SAMMLUNG VON MEDAILLEN, PLAKETTEN UND JETONS AUS DER REGIERUNGSZEIT DER KAISER FERDINAND I. UND FRANZ JOSEF I.** Horn: Berger & Söhne, 2006. Two volumes. 4to, original matching green cloth, gilt. xxvii, (1), 1086 pages plus advertising leaves. Fine. **\$100**

A massive and well-indexed catalogue with over 8000 listings. Ex Richard E. Margolis Library.

Classic Work on British Silver

234 Hawkins, Edward. **THE SILVER COINS OF ENGLAND, ARRANGED AND DESCRIBED; WITH REMARKS ON BRITISH MONEY PREVIOUS TO THE SAXON DYNASTIES... SECOND EDITION, WITH ALTERATIONS AND ADDITIONS BY R.L.L. KENYON.** Second edition, with alterations and additions by R.L.L. Kenyon. London: Quaritch, 1876. 8vo, original brown quarter morocco, gilt; top page edges gilt. Finely engraved frontispiece plate; (2), vi, 504 pages; 47 + 7 engraved plates of coins. Previous owner's stamp on flyleaf. Very good. **\$100**

The revised edition of this classic work. Ex Richard E. Margolis Library.

The Medallic Work of Antoine Bovy

235 Henseler, Ant. **ANTOINE BOVY, ARTISTE-GRAVEUR EN MÉDAILLES: SA VIE ET SES PRINCIPALES OEUVRES.** Fribourg, 1881. Thin 4to, later blue cloth, gilt. 100, (8) pages; 6 fine plates. First signature loose; very good. **\$100**

Scarce, with fine plates. Ex Richard E. Margolis Library.

Early Hess & Helbing Sales

236 Hess (Nachf.), Adolph. **MÜNZEN UND MEDAILLEN VERSCHIEDENER LÄNDER... MEDAILLEN AUS DER ZEIT DER FRANZÖSISCHEN REVOLUTION UND DES ERSTEN KAISERREICHS... BRANDENBURG-PREUSSISCHE THALER... REICHHALTIGE SAMMLUNG VON MEDAILLEN AUF PRIVATPERSONEN....** Frankfurt am Main, 4. Mai 1903 und folgende Tage. 8vo, original printed paper covers. (2), 238 pages; 5145 lots; 2 fine plates. Very good or better. [*with*] Helbing, Otto. **AUCTIONS-CATALOG ENTHALTEND DIE SAMMLUNGEN DES HERRN ALBERT WEINREB ... KARL FABER ... KONRAD KIRCHNER...** München, 12. Dezember 1904 und folgende Tage. 8vo, original printed paper covers. (8), 235, (1) pages; 5552 lots; 16 fine plates. Spine worn near head; very good or better. **\$120**

Well-preserved copies of these very scarce catalogues. While the two plates in the Hess catalogue are devoted to the enormous and important collection of personal medals offered in the sale, it is the offering of material from the French Revolution and Napoleonic era (pages 36–74, lots 1110–1694) that earned its place in the Margolis Library. The Helbing catalogue features 16 excellent plates, including two devoted to ancient coins. Spring 290 (the earliest Helbing sale listed by Spring). Ex Richard E. Margolis Library.

The Complete Erbstein Collection

237 Hess (Nachf.), Adolph. SAMMLUNG ERBSTEIN. NACHLASS DES † HERRN GEH. HOFRATHS DR. RICHARD JULIUS ERBSTEIN. The complete sale:

- I. ABTHEILUNG: ITALIENISCHE UND DEUTSCHE RENAISSANCE-MEDAILLEN.
- II. ABTHEILUNG: MÜNZEN UND MEDAILLEN DER KAISER, KÖNIGE, PÄPSTE UND GEISTLICHEN FÜRSTEN.
- III. ABTHEILUNG: MÜNZEN UND MEDAILLEN DER ALTFÜRSTLICHEN HÄUSER.
- IV. ABTHEILUNG: MÜNZEN UND MEDAILLEN DER NEUFÜRSTLICHEN HÄUSER, DER SCHWEIZ, ITALIENS UND DER NIEDERLANDE.
- V. ABTHEILUNG: MÜNZEN UND MEDAILLEN DER STÄDTE UND ÜBERSEEISCHEN LÄNDER, MEDAILLEN AUF PRIVATPERSONEN, MISCELLANEA, NACHTRAG.
- VI. ABTHEILUNG: MÜNZEN DES MITTELALTERS.

Frankfurt am Main, 18.–19. Mai 1908, 18. Januar 1909, 25. Oktober 1909, 18. April 1910, 9. Januar 1911, 13. November 1911. Six parts bound in three volumes. 4to, later black cloth, gilt. 1366 pages; 21,535 lots; 50 very fine plates; prices realized lists for all six parts present. Fine. **\$500**

The enormous and indispensable Erbstein collection, with fine plates and complete prices realized lists. Clain-Stefanelli 6539, 7973, 9144, 10541 and 14357; Grierson 271 ("Collection très riche, surtout pour l'Allemagne, mais de qualité inégale").

**1932 Sale of Russian Museum "Duplicates"**

238 Hess (Nachf.), Adolph. RUSSISCHE MÜNZEN DES 14.–18. JAHRHUNDERTS. DUBLETTEN RUSSISCHER MUSEEN. Frankfurt am Main: 25. April 1932. 4to, original printed card covers. (2), 53, (3) pages; 1956 lots; 11 fine plates. Covers a bit worn and discolored; very good. **\$400**

The second of two astonishing sales of Russian coins, consigned by the Soviet Philatelic Agency and presented as duplicates. Essentially, A. Tolmatscheff-Sosnowski and A. Werschinin formed an outstanding and comprehensive collection by making selections from various institutional holdings. Especially rich in rare gold and silver coins of Kiev. Zander, in his "Collector's Selective Guide to Russian Numismatic Literature," described the sales as "a stunning series with many great rarities." This catalogue focuses most heavily on the 18th-century coinage. Clain-Stefanelli 11223*.

Two Works on Renaissance Medals

239 Hill, G.F. PORTRAIT MEDALS OF ITALIAN ARTISTS OF THE RENAISSANCE. ILLUSTRATED AND DESCRIBED, WITH AN INTRODUCTORY ESSAY ON THE ITALIAN MEDAL. London, 1912. 4to, original red cloth, gilt; top page edges gilt. Color frontispiece; xvii, (3), 92, (2), (2) pages; 32 exceptionally fine plates. Binding a bit worn, with rear cover badly discolored. Contents near fine. [with] Fabriczy, Cornelius von. MEDAILLEN DER ITALIENISCHEN RENAISSANCE. Leipzig, (1903). Small 4to, slightly later red cloth with hand-lettered cover label. 108, (4) pages; 181 text illustrations of medals. Very good or so. **\$100**

Hill's work is a handsome production, one of only 750 copies printed. Clain-Stefanelli 14284 and 14271. Ex Richard E. Margolis Library.

Renaissance Medal Plates

240 Hill, G.F. [editor]. SELECT ITALIAN MEDALS OF THE RENAISSANCE IN THE BRITISH MUSEUM. London: British Museum, 1915. 4to, original cloth-backed portfolio with ties. 16 pages; 50 fine collotype plates. Near fine. **\$100**
Attractively printed plates. Ex Richard E. Margolis Library.

German Propaganda Medals of the First World War

241 Hill, G.F. THE COMMEMORATIVE MEDAL IN THE SERVICE OF GERMANY. London, 1917. 8vo, later green cloth, gilt; original printed front paper cover bound in. 32 pages; illustrated. Fine. **\$100**

An interesting work on German World War I propaganda medals. Scarce. Ex Richard E. Margolis Library.

Hoffmann's Foreign Coins

242 Hoffmann, H. COLLECTION H. HOFFMANN. MONNAIES FRANÇAISES. DEUXIÈME PARTIE, DEPUIS HUGUES-CAPET JUSQU'À NOS JOURS. Paris, 4–6 avril 1887. 8vo, later gray cloth, gilt; original printed paper covers bound in. (4), (33)–120 pages; lots 420–1614; 2 lithographic plates engraved by Dardel. Some spotting; near fine. **\$100**

The second part of Hoffmann's sale of French coins. In his introduction to the sale, he writes: "Après m'être consacré pendant quarante-cinq ans au commerce des médailles, je me suis décidé à cesser les affaires, et à ne plus m'occuper, dorénavant, de numismatique que comme expert et comme amateur. Au mois de mai dernier, j'ai commencé la liquidation de mes médailliers par la vente de mes monnaies étrangères. Les monnaies françaises, dont le catalogue se distribue aujourd'hui, seront vendues en deux parties: la première comprenant les pièces gauloises, mérovingiennes et carolingiennes; la deuxième comprenant les capétiennes, les monnaies de la Révolution et de l'époque contemporaine. On trouvera sur la première planche du catalogue une série de pièces qui ne figurent pas dans l'ouvrage que j'ai publié en 1878 sous le titre de *Monnaies royales de France*." Ex Richard E. Margolis Library.

Visit our online store at
numislit.com
to browse even more titles

French Almanac for 1791

243 d'Houry, Laurent [founder]. *ALMANACH ROYAL, AN-NÉE COMMUNE M.DCC.XCI. PRÉSENTÉ A SA MAJESTÉ POUR LA PREMIERE FOIS EN 1699*. Paris: Imprimerie de la Veuve d'Houry, (1790). 8vo, original mottled brown calf; spine with five raised bands, decorated in gilt; red spine label, gilt; red page edges; hand-marbled endpapers. 720 + 8 pages. Binding worn at spine and rubbed at extremities; very good. **\$150**

One of the most important editions of this long-running almanac, published under various titles from 1699 to 1919. This edition, published in 1790 for 1791, includes much useful information concerning the administration of the French government during the tumultuous period of the French Revolution.

The State of Numismatic Research

244 International Numismatic Commission. *A SURVEY OF NUMISMATIC RESEARCH, 1960–1965*. Copenhagen, 1967. Three volumes. 8vo, original matching printed card covers. 762 pages. Lightly sunned; minor marks to covers; near fine. [with] *A SURVEY OF NUMISMATIC RESEARCH, 1966–1971*. Three volumes. New York, 1973. 8vo, original matching printed card covers. vi, 372, (18); viii, 373, (11); viii, 374, (18) pages. Signed by Elvira Clain-Stefanelli at her article in Volume III. Lightly sunned; minor marks to covers; near fine. [with] *A SURVEY OF NUMISMATIC RESEARCH, 1978–1984*. London, 1986. Two volumes. 8vo, original matching printed card covers. ix, (1), 689, (1); (4), 691–1076, (22) pages. Fine. [with] *A SURVEY OF NUMISMATIC RESEARCH, 1985–1990*. Brussels, 1991. Two volumes. 8vo, original matching printed card covers. x, 458; (4), 459–896 pages. Fine. **\$150**

Important overviews, generally under-utilized and under-appreciated. Ex Frank and Laurese Katzen library, with their bookplates in each volume. Clain-Stefanelli 25*. Grierson 22. Ex TAB Library.

Classic Study of Bosnian & Serbian Coins

245 János, Érdy. *A BOSZNA ÉS SZERB RÉGI ÉRMEK*. Budán, 1857 [cover imprint: Pest, 1858]. 4to, original printed tan wrappers. 40, (2) pages; genealogical table; numerous fine engravings of coins in the text; 1 fine seal plate. Blank portion of title excised and neatly repaired; minimal internal discoloration. Very good. **\$100**

A rare study of early Bosnian and Serbian coins. Ex Kolbe Sale 81, lot 1586.

Indian Paper Money Reference

246 Jhunjhunwalla, Kishore, and Rezwan Razack. *THE REVISED STANDARD REFERENCE GUIDE TO INDIAN PAPER MONEY*. Mumbai, 2012. 4to, original tan cloth lettered in copper; mounted color illustration; decorative endpapers; as issued in matching slipcase. xviii, 607 pages [including rear flyleaf recto]; illustrated throughout in color. Signed by both authors on title page. Fine. **\$100**

A lavishly illustrated and well-produced reference. Ex TAB Library.

German Aviation Medals

247 Kaiser, Hans. *MEDAILLEN, PLAKETTEN, ABZEICHEN DER DEUTSCHEN LUFTFAHRT. DIE GEPRÄGTE*

CHRONIK DER DEUTSCHEN LUFTFAHRT. Gütersloh: B. Strothotte, 1998. 4to, original pictorial boards. (2), vii, (1), 654 pages; 2134 detailed listings; illustrated throughout. Fine. **\$100**
An indispensable reference on medals pertaining to air flight. Ex Richard E. Margolis Library.

First Edition of Kann on Chinese Coins

248 Kann, E. *ILLUSTRATED CATALOG OF CHINESE COINS (GOLD, SILVER, NICKEL AND ALUMINUM)*. Los Angeles, 1954. First edition. 8vo, original printed gray cloth; jacket. 476, (2) pages; 224 plates. Jacket taped; very good. **\$150**
The original edition of this important work, with better plates than those in the reprints. Clain-Stefanelli 8643*.

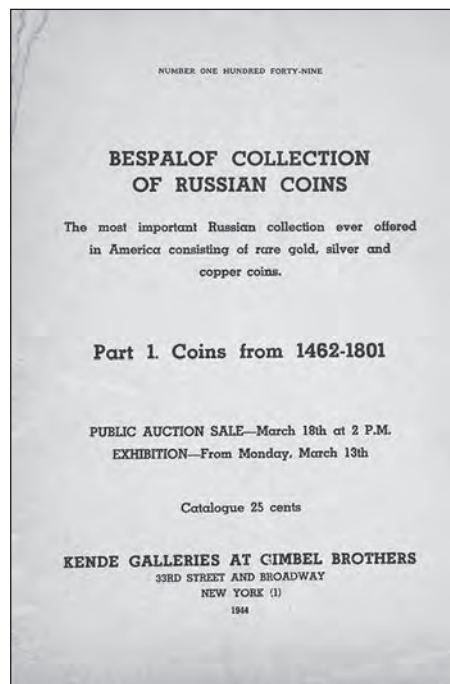

Priced Catalogue of the Bespalof Russian Coins

249 Kende Galleries. *BESPALOF COLLECTION OF RUSSIAN COINS. THE MOST IMPORTANT RUSSIAN COLLECTION EVER OFFERED IN AMERICA CONSISTING OF RARE GOLD, SILVER AND COPPER COINS. PART 1: COINS FROM 1462–1801*. New York: Gimbel Brothers, March 18, 1944. 8vo, original printed card covers. 17 pages; 225 lots; 5 plates of coins. Hand-priced in pencil, with some coded annotations. Very good. **\$350**

An important sale of Russian coins that is usually encountered in poor condition when a copy can be found at all. Apparently a sales room copy, featuring bids entered in code as well as the prices realized. A similar copy sold in our sale of the Quentin Archer Library for \$750 plus the premium. Very scarce, especially priced.

The Coinage of Osnabrück

250 Kennepohl, Karl. *DIE MÜNZEN VON OSNABRÜCK. DIE PRÄGUNGEN DES BISTUMS UND DES DOMKAPITELS OSNABRÜCK, SOWIE DES KOLLEGIATSTIFTES UND DER STADT WIEDENBRÜCK*. Munich: Kreß & Hornung, 1938. Large 4to, original russet cloth lettered in black;

Trésor Volume on Medals of the French Revolution

257 Lenormant, Charles, Paul Delaroché and Henriquel Dupont. TRÉSOR DE NUMISMATIQUE ET DE GLYPTIQUE, OU RECUEIL GÉNÉRAL DE MÉDAILLES, MONNAIES, PIERRES GRAVÉES, BAS-RELIEFS, ETC., TANT ANCIENS QUE MODERNES, LES PLUS INTÉRESSANS SOUS LE RAPPORT DE L'ART ET DE L'HISTOIRE, GRAVÉ PAR LES PROCÉDÉS DE M. ACHILLE COLLAS. [Volume XVII]: MÉDAILLES DE LA RÉVOLUTION FRANÇAISE, DEPUIS L'OUVERTURE DES ÉTATS-GÉNÉRAUX (5 MAI 1789) JUSQU'À LA PROCLAMATION DE L'EMPIRE (18 MAI 1804). A Paris: Chez Rittner et Goupil, 1836. First edition. Folio [46 by 31 cm], somewhat later black half morocco; spine with five raised bands, lettered in gilt. (4), 132 pages; 96 exceptionally fine plates produced using the medal ruling machine technique, with tissue guards, depicting medals and jetons. Binding rubbed and a bit worn, but sound; text leaves with the usual foxing; plates more lightly foxed. Pages untrimmed. Very good or better. **\$500**

The French Revolution volume, from the extraordinary 20-volume *Trésor de numismatique et de glyptique*, the outstanding 19th-century contribution to medallic and glyptic art. David Block discussed this work in the Summer 1985 issue of *The Asylum*: "The great illustrated catalogs of Napoleonic medals are part of Charles Lenormant's *Trésor de numismatique et de glyptique*... The volume containing medals of the French revolution first appeared in 1836, followed several years later by a volume covering the First Empire ... the editors published for the first time many medals from imperial times." The text in this volume was written by George-Julien Fellmann, under the general



editorship of Lenormant. The massive, extensively illustrated *Trésor* has never been approached in concept or scope. The plates utilized a new process, perfected in France by Achille Collas. They were engraved with a pantographic ruling machine and, in addition to being of great visual appeal, the illustrations were the most accurate ever achieved. This technical innovation, widely heralded at the time, was, within a few decades, overtaken by photographic printing processes and is relatively little known today. Clain-Stefanelli 14551*. Engel et Serrure 3973. Grierson 255: "Bon recueil de planches et bon texte descriptif. Classé essentiellement par pays et très utile pour les séries françaises, surtout pour la Révolution française et pour Napoléon." Ex Hon. Arthur Dillon, with his armorial bookplate; ex Richard E. Margolis Library.

black calf spine label, gilt. xv, (1), 396 pages; text illustrations; map; 43 fine plates. Near fine. **\$150**

The scarce original edition of this classic work on the medieval and modern coins and medals of Osnabrück, with fine plates. Clain-Stefanelli 9476. Grierson 150.

Modern Works on Saxon Talers

251 Kohl, Christian A. TALERTEILSTÜCKE DES KURFÜRSTENTUMS SACHSEN. TYPENKATALOG ALBERTINISCHE LINIE 1547-1763. Leipzig, 1994. 4to, original brown cloth, gilt. 230, (2) pages; illustrated. Price list laid in. Fine. [with] Keilitz, Claus, and Christian A. Kohl. TALERTEILSTÜCKE DES KURFÜRSTENTUMS SACHSEN. ERWEITERTER TYPENKATALOG DER GEMEINSCHAFTSPRÄGUNGEN BEIDER SÄCHSISCHER LINIEN, SOWIE DER VON BEIDEN LINIEN ALLEIN HERAUSGEGEBENEN MÜNZEN 1500-1547. Leipzig, 1996. 4to, original brown cloth, gilt. 91, (1) pages; illustrated. Price list laid in. Fine. **\$100**

Useful modern works. Ex Richard E. Margolis Library.

Important Collection on Islamic Numismatics

252 Kouymjian, Dickran K. [editor]. NEAR EASTERN NUMISMATICS, ICONOGRAPHY, EPIGRAPHY AND HISTORY: STUDIES IN HONOR OF GEORGE C. MILES. Beirut: American University of Beirut 1974. 4to, original blue cloth, gilt;

jacket. xxv, (1), 478, (2) pages; portrait; numerous text illustrations. Jacket worn; a little musty. Very good. **\$100**

A very important and scarce festschrift, with content that goes well beyond Islamic numismatics (though that is the dominant focus). Clain-Stefanelli 17795. Grierson 225.

Classic Work on Hamburg

253 Langermann, Joh. Paul. HAMBURGISCHES MÜNZ- UND MEDAILLEN-VERGNÜGEN ODER ABBILDUNG UND BESCHREIBUNG HAMBURGISCHER MÜNZEN UND MEDAILLEN... Hamburg, 1975 Tietjen reprint. Thick 8vo, handsomely bound by Sangorski & Sutcliffe in black levant three-quarter morocco; spine with five raised bands, lettered in gilt; marbled endpapers; top page edges gilt; silk headbands. (98), 640, (24) pages; 80 plates of coins and medals. Slight rubbing to extremities; near fine. **\$100**

A great classic work. No. 23 of only 100 copies reprinted. Ex Randolph Zander Library; ex Roger Tobin Library (Kolbe & Fanning Sale 139, lot 78); ex Richard E. Margolis Library.

Medals of the Chamber of Deputies

254 Launay, Edmond. COSTUMES, INSIGNES, CARTES, MÉDAILLES DES DÉPUTÉS 1789-1898. Paris: Motteroz, 1899. 4to, later red cloth; spine lettered and decorated in gilt; marbled endpapers; original pictorial card covers bound in. (8),

257, (1) pages; 12 hand-tinted plates of costumes and 1 plate of insignia; numerous text illustrations of medals, cards, etc., many of them hand-tinted. Near fine. **\$100**

An excellent history of the costumes, insignia, identity cards and medals of the Chamber of Deputies of the French Legislative Assembly, based on the Chamber's own extensive collection. Rare. Suetens 539. Ex Richard E. Margolis Library.

Islamic Coins in the Bibliothèque Nationale

255 I: KHALIFES ORIENTAUX. II: ESPAGNE ET AFRIQUE. III: ÉGYPTTE ET SYRIE. Bologna: Forni, 1977 reprints of the 1887–1896 originals. Three volumes, complete. 8vo, original matching yellow cloth lettered in red and black. 1682 pages plus 122 pages of preliminaries; 34 plates of coins. Near fine. **\$350**

The complete set of reprints of this extensive major reference on Islamic coins. The first volume covers the Umayyads and Abbasids; the second covers the Umayyads in Spain, Reyes de Taifas, Almoravids, Almohads, Nasrids, Aghlabids, Idrisids, Hafsid, Marinids, Zayanids and Sharifs of Morocco; and the final volume covers the Tulunids, Ikshhidids, Fatimids, Ayyubids, and Mamluks. Clain-Stefanelli 5879*. Mayer 1034.

Siam Society's Numismatic Publications

256 Le May, Reginald. THE COINAGE OF SIAM. Bangkok, 1961 reprint. (2), xi, (1), 134 pages; text figures; 32 plates. [with] STUDIES OF OLD SIAMESE COINS. SELECTED ARTICLES FROM THE SIAM SOCIETY JOURNAL. Bangkok, 1961. 148 pages; illustrated. Both small 4to, original printed card covers. Near fine. **\$100**

Both publications of the Siam Society, Volumes 9 and 10. Ex Richard E. Margolis Library.

Rarely Seen Publication on Medals

258 Leotti, Elaine [editor]. THE MEDALLIST. Volumes 1–7 (Oceanside, etc., 1984–1990), complete. First five volumes bound in one volume [4to, later brown cloth, gilt]; balance of set inserted loose, as published. 162 pages; illustrated. A few inserts throughout. Fine. **\$100**

A complete set of this little-known publication, the first we recall offering. Published at first on a "sort-of-regular basis," the publication focused on "medals both portrait and commemorative to the exclusion of all other numismatics including the recently minted 'collectibles.'" Ex Richard E. Margolis Library.

Rousseau Collection of Early French Coinage

259 Longpérier, Adrien de. NOTICE DES MONNAIES FRANÇAISES COMPOSANT LA COLLECTION DE M. J. ROUSSEAU, ACCOMPAGNÉE D'INDICATIONS HISTORIQUES ET GEOGRAPHIQUES, ET PRÉCÉDÉE DE CONSIDÉRATIONS SUR L'ÉTUDE DE LA NUMISMATIQUE FRANÇAISE. Paris, 1847. 8vo, contemporary tan quarter calf with mottled sides; spine ruled in gilt; black spine label, gilt. (4), xvi, 276 pages; text figures; 3 + 6 lithographic plates of coins. Very good or better. **\$100**

An original copy of this important catalogue of Carolingian and Merovingian coins. Engel & Serrure 4178. Ex Richard E. Margolis Library.

The Recoinage of William of Orange

260 Lowndes, William [anonymous]. A REPORT CONTAINING AN ESSAY FOR THE AMENDMENT OF THE SILVER COINS. London: Printed by Charles Bill, and the Executrix of Thomas Newcomb, deceased; Printers to the Kings most Excellent Majesty, 1695. 8vo, modern brown quarter calf in antique style, decorated in blind with marbled sides; spine ruled in gilt, burgundy spine label lettered in gilt. 159, (1) pages; woodcut decorations; text table. Margins of title page and three other leaves professionally repaired. An attractive copy; very good or better. **\$250**

The first and only edition. Quite scarce. Lowndes's Report was a major contribution to the controversy surrounding the recoinage under William III, the principal protagonists being Lowndes, then Secretary to the Treasury, and John Locke. In this work, Lowndes reviews the expedients of former reigns, urges a recoinage, and suggests a change in the standard by raising the nominal value of all coins by 25%. Dekesel L135. Goldsmith 3131. Hirsch 78. Kress 1908. Lipsius 235. Manville 52 (quoting William Nicolson's *English Historical Library* as follows: "Mr. Lowndes has written in so peculiar & instructive a manner, that our Historians may learn better, by his little Book, how to distinguish and value the Coins of our several Kings, than from all the Volumes of our English Antiquaries.") Soetbeer 27. Wing L. 3323.



Irish Tradesmen's Tokens

261 Macalister, R.A.S. A CATALOGUE OF THE IRISH TRADERS' TOKENS IN THE COLLECTION OF THE ROYAL IRISH ACADEMY. Dublin, 1931. *Proceedings of the Royal Irish Academy*, Volume XL, Section C, No. 2. Large 8vo, recent green linen, gilt; original printed paper covers bound in. (19)–186 pages, complete. Early ownership notation on front paper cover; upper corner of pages bumped. Near fine, in a new binding. **\$120**

Important and scarce. The nucleus of the token collection of the Royal Irish Academy, spanning the 17th to 19th centuries, was the collection of the great Irish numismatist Dr. Aquilla Smith. Especially important for Macalister's detailed descriptions of the 17th-century tokens, for which the Williamson/Boyne descriptions are frequently insufficient.

Anglo-Scandinavian Coinage

262 Malmer, Brita. THE ANGLO-SCANDINAVIAN COINAGE c. 995–1020. Stockholm: Royal Swedish Academy of Letters, History and Antiquities, 1997. Crown 4to, original blue cloth lettered and decorated in silver; jacket. 634, (6) pages; plates depicting nearly 3000 coins; 1 folding table. Fine. **\$100**

A very substantial work. *Commetationes de Nummis Saeculorum IX–XI in Suecia Repertis*: Nova Series 9. Ex Roger Persichilli Library.

The Ernest Gariel Collection at Auxerre

263 Manificier, Victor. CATALOGUE DES MONNAIES, MÉREAUX JETONS ET MÉDAILLES DE LA COLLECTION GARIEL AU MUSÉE DE LA VILLE D'AUXERRE. 1908. 8vo, original printed wraps. 223, (1) pages. Some wear to covers, with lower corner chipped. Else near fine. **\$100**

A rarely encountered museum catalogue. Ex Richard E. Margolis Library.

The Wallace Collections at Hertford House

264 Mann, J.G. WALLACE COLLECTION CATALOGUES. SCULPTURE: MARBLES, TERRA-COTTAS AND BRONZES, CARVINGS IN IVORY AND WOOD, PLAQUETTES, MEDALS, COINS, AND WAX-RELIEFS. London, 1931. 8vo, original printed card covers. Frontispiece; xxvi, 238 pages; 99 plates, including 14 of plaquettes, medals and coins. Two inserted photographs. Covers a bit faded; very good. [with] Gibson, W.P. WALLACE COLLECTION CATALOGUES. MINIATURES AND ILLUMINATIONS. London, 1935. 8vo, original printed card covers. xii, 177 pages, 55 plates. Covers a bit faded; very good. **\$100**

The extensive collections of Sir Richard Wallace. Ex Richard E. Margolis Library.

Iconography of the Kings of France

265 Maumené, Lt.-Colonel Ch., and Comte Louis d'Harcourt. ICONOGRAPHIE DES ROIS DE FRANCE. Paris: Librairie Armand Colin, 1929 & 1932. Two volumes. 8vo, later matching blue cloth, gilt. vii, (1), 302, (2) + vii, (1), 554, (2) pages; 40 phototype plates in each volume. Occasional annotations. Near fine. **\$100**

An interesting compendium, with some of the illustrations being numismatic. Ex Richard E. Margolis Library.

Medals of the Revolutionary Era

266 [Medals]. MONOGRAPHS ON MEDALS OF THE FRENCH REVOLUTION AND EMPIRE. Includes: the Hôtel des Monnaies's 1946–1947 *Exposition des médailles et des monnaies de la Révolution française et de la première République*; the Hôtel des Monnaies's 1937 *Exposition de médailles Napoléoniennes*; Marc Brisac's 1905 *La monnaie de Lyon pendant la Révolution: I. L'Hôtel des Monnaies en 1791*; C.J. Kortebach's 1934 *De Fransche Revolutie: de medailles en decoraties betreffende de verovering van de Bastille 1789–1792*; and Mark Jones's 1977 *Medals of the French Revolution*. Five titles in total. Varying card- or paper-covered formats. Condition generally very good or better. **\$100**

Includes some interesting specialized studies and exhibition catalogues. Ex Richard E. Margolis Library.

Works on Medals

267 [Medals]. MONOGRAPHS ON MEDALS AND RELATED SUBJECTS. Includes: A.-H. Martinié's 1930 *Pisanello*; P. Olivier's 1931 *Les médailles de Berryer*; E. Pariset's 1905 *La médaille énigmatique*; Ed. Angérad's 1910 *Une médaille d'or de la chambre de commerce de Rouen*; P. Charles Robert's 1874 *Médailles commémoratives de la défense de Metz en 1552*; J. Rouyer's 1887 *Médailles du règne de Louis XIV se rapportant à l'histoire des Pays-Bas et dont les coins existent au Musée Monétaire à Paris*; A. de Meunynck's 1899 *L'Arc triomphal de Louis XIV (Porte de Paris) à Lille et sa médaille à l'occasion de l'inauguration de ce*

monument restaure (1695–1895); Charles & Jules Florange's 1925 *Les décorations et insignes des chapitres nobles de France avant 1789*; and Jules Florange's 1936 *L'Amour et le mariage dans la numismatique*. Nine titles in total. Varying card- or paper-covered formats. Condition generally very good or better. **\$150**

Includes some interesting specialized studies, many of them scarce. The final monograph is Clain-Stefanelli 16340. Ex Richard E. Margolis Library.

Early Medieval European Coinage

268 [Medieval European Coinage]. MEDIEVAL EUROPEAN COINAGE. WITH A CATALOGUE OF THE COINS IN THE FITZWILLIAM MUSEUM, CAMBRIDGE. 1: THE EARLY MIDDLE AGES (5TH–10TH CENTURIES). Cambridge: Cambridge University Press, 1986. By Philip Grierson and Mark Blackburn. 8vo, original blue cloth, gilt; jacket. xxi, (1), 674 pages; 65 plates of coins; endpaper maps. Jacket sunned, else fine. **\$150**

The original edition of this groundbreaking work, with superior plates. Of considerable importance. Ex TAB Library.

Two Works by George Miles

269 Miles, George C. THE COINAGE OF THE VISIGOTHS OF SPAIN, LEOVIGILD TO ACHILA II. New York: ANS, 1952. xv, (1), 519, (1) pages; folding map and alphabetical table; 44 fine plates. [with] Miles, George C. COINS OF THE SPANISH MULUK AL-TAWA'IF. New York: ANS, 1954. xi, (1), 168 pages; 15 fine plates. Two volumes. Both 8vo, original printed russet card covers. A little dusty; very good or better. **\$100**

Hispanic Numismatic Series Nos. 2 and 3. Still important. Clain-Stefanelli 5628*. Grierson 116 and 170. Ex Richard E. Margolis Library.

Austrian Coinage 1519–1938

270 Miller zu Aichholz, V., A. Loehr and E. Holzmair. ÖSTERREICHISCHE MÜNZPRÄGUNGEN 1519–1938. Chicago, 1981 reprint of the second edition. Two volumes. Oblong folio, original gray and red embossed cloth, gilt. (2), xl, 354 + 14 pages; 56 plates. Fine. **\$100**

The indispensable standard work, covering the entire range of Austrian numismatics. Clain-Stefanelli 8217*.

Extensive Bibliography of Medals

271 Modesti, Adolfo, and Roberto Ginocchi. NUMISMATA IN LIBRIS. Rome, 1997. 4to, original red boards, gilt; jacket. (2), 816 pages; illustrated; 2508 detailed listings; errata laid in. Near fine. **\$100**

A monumental "catalogue of a private collection of books, magazines, articles, and various writings from the sixteenth to the twentieth century related to the art of the medal, concerning mainly Italy." Kolbe 167. Ex Richard E. Margolis Library.

Modesti on Early Papal Medals

272 Modesti, Adolfo. CORPUS NUMISMATUM OMNIUM ROMANORUM PONTIFICUM. VOLUME I: DA S. PIETRO (42–67) A ADRIANO VI (1522–1523). Roma, 2002. 677, (3) pages; illustrated. Jacket a little worn; near fine. **\$150**

The first volume of this comprehensive corpus of Papal medals, by the foremost authority on the subject. Each medal is depicted at actual size and full metrology is given as well as a detailed description.

Comprehensive Bibliography on Medals

273 Modesti, Adolfo, and Roberto Ginocchi. NUMISMATA IN LIBRIS. Second edition. Rome, 2005. 4to, original red boards, gilt. 914, (2) pages; illustrated; 3274 detailed listings. Fine. **\$150**
The 2005 revision of this monumental bibliography of the literature on medals, pertaining primarily (though not exclusively) to Italy.

Restitution Medals of the Popes

274 Modesti, Adolfo. CORPUS NUMISMATUM OMNIUM ROMANORUM PONTIFICUM. VOLUME V: LE MEDAGLIE PAPALI DI RESTITUZIONE. Rome, 2015. 4to, original red cloth; jacket. 278 pages; illustrated in color throughout. Fine. **\$150**
The fifth volume of this comprehensive corpus of Papal medals, by the foremost authority on the subject. Each medal is depicted at actual size and full metrology is given as well as a detailed description.

The Catholic Church in Medals

275 Modesti, Adolfo. LE CHIESE CATTOLICHE NELLA MEDAGLIA D'ARTE: STORIA, ARCHITETTURE, MONUMENTI, ARTISTI E ALTRO NELLE MEDAGLIE DI UN'ORIGINALE "COLLEZIONE ROMANA." Rome, 2016. Edited and curated by Adolfo Modesti under the aegis of the Accademia Italiana di Studi Numismatica. Folio, original red cloth; pictorial jacket. 587, (1) pages; illustrated throughout in color. Fine. **\$200**
One of only 50 copies produced of this monumental volume of essays on Catholic churches, cathedrals, basilicas, monasteries, etc., in Italy, illustrated through an outstanding collection of 363 medals.

The Tyrolean Mint

276 Moser, Heinz, and Heinz Tursky. DIE MÜNZSTÄTTE HALL IN TIROL 1665–1809. Innsbruck, 1981. 4to, original gray linen lettered in black; jacket. 280 pages; well illustrated. Jacket with light wear, else fine. **\$100**
Scarce and still important. Ex TAB Library.



Yugoslavian Guide to False Bank Note Detection

277 Narodna Banka, Federativne Narodne Republike Jugoslavije. ZBIRKA OPISA STRANIH NOV ANICA, KOVANOG ZLATNOG NOVKA I NJIHOVIH FALSIFIKATA. I: OPIS STRANIH NOV ANICA POJEDINIHZEMALJA. II: OPIS FALSIFIKATA STRANIH NOV ANICA POJEDINIHZEMALJA. [COLLECTION OF DESCRIPTION OF

FOREIGN BANKNOTES, FORGED GOLD COINS AND THEIR COUNTERFEITS. I: DESCRIPTION OF FOREIGN BANKNOTES OF CERTAIN COUNTRIES. II: DESCRIPTION OF COUNTERFEIT FOREIGN BANKNOTES OF CERTAIN COUNTRIES.] Beograd, 1958. 230 leaves, mostly printed on both sides, many with illustrations of both sides of a bank note, and a coin or two, accompanied by descriptive text. Small 8vo, original tan linen folder, lettered in black; original brass bar and screws holding contents together. Covers and title a bit discolored; very good. **\$300**

A useful identification guide issued by the Yugoslavian National Bank for internal use by bank officers to enable them to differentiate between genuine and counterfeit notes. Depicted are genuine, specimen, and counterfeit notes of various denominations and issuing entities, including Argentina, Australia, Austria, Belgium, Brazil, Czechoslovakia, Denmark, Egypt, England, France, Germany, Greece, Hungary, Italy, Norway, Poland, Sweden, Switzerland, Turkey, and the United States of America. Illustrated are notes mostly of the 1950s, some earlier. An extremely rare early pictorial and factual record of widely circulating world paper money in the mid-twentieth century. Ex Kolbe Sale 112, lot 463 (at \$600 hammer).

The Wayte Raymond Collection

278 NASCA. THE WAYTE RAYMOND COLLECTION OF COINS AND MEDALS OF THE WORLD. PARTS I–IV. New York, 1977–1978. 4to, original blue cloth, gilt; original printed card covers bound in. 160; 139, (5); 156; 100 pages; 3714 + 4573 + 4201 + 1609 lots; numerous text illustrations; plate supplements and prices realized lists bound in throughout. Fine. **\$150**
The Special Hardbound Edition. Gengerke page 149: "The only deluxe edition ever produced was a single volume containing the four Wayte Raymond sales and associated plate volumes. According to an advertisement, 53 were made." Ex Richard E. Margolis Library.

The Medals of Giuseppe Verdi

279 Nataletti, Giorgio & Pagani, Antonio. LE MEDAGLIE DI GIUSEPPE VERDI. Roma: Estratto dal *Volume Verdi*, 1941. Folio, later brown quarter calf, gilt. 98 pages; table; 132 detailed listings, each with a halftone illustration. Spine rubbed; very good. **\$100**
Rare, and most interesting. Ex Stack's Numismatic Library; ex Richard E. Margolis Library.

Byzantine Seals at Dumbarton Oaks

280 Nesbitt, John, and Nicolas Oikonomides [editors]. CATALOGUE OF BYZANTINE SEALS AT DUMBARTON OAKS AND IN THE FOGG MUSEUM OF ART. VOLUME 1: ITALY, NORTH OF THE BALKANS, NORTH OF THE BLACK SEA. [with] VOLUME 2: SOUTH OF THE BALKANS, AND ISLANDS, SOUTH OF ASIA MINOR. [with] VOLUME 4: THE EAST. [with] VOLUME 5: THE EAST (CONTINUED), CONSTANTINOPLE AND ENVIRONS, UNKNOWN LOCATIONS, ADDENDA, UNCERTAIN READINGS. [with] VOLUME 6: EMPERORS, PATRIARCHS OF CONSTANTINOPLE, ADDENDA. Washington, D.C., 1991–2009. Five volumes, lacking only the third for completion. 4to, original matching gray cloth, gilt. Over 1200 pages; numerous text illustrations. Fine; two volumes still in shrink-wrap. **\$100**
Five of the six volumes published of this important standard work.

Original Printings of Third Edition

281 North, Jeffrey J. ENGLISH HAMMERED COINAGE. VOLUMES 1 & 2: EARLY ANGLO-SAXON TO CHARLES II, C. 600–1662. London, 1994 and 1991. Third edition, first printings. Two volumes, complete. 8vo, original matching blue boards, gilt; jackets. 271; 225, (3) pages; text illustrations; 31 plates of coins with facing text. Near fine. **\$120**

The original printings of the current edition of the standard work, considered to have somewhat better plates than the more recent reprints.

Noss on German Coins

282 Noss, Alfred. DIE MÜNZEN VON JÜLICH, MÖRS UND ALPEN. München, 1927. 4to, original green cloth-backed boards, lettered in black. xiv, 164, (2) pages; map; genealogical table; 12 fine plates of coins. Very good or better. [with] Noss, Alfred. DIE MÜNZEN VON BERG UND JÜLICH-BERG. München: Kress & Hornung, 1929. Two volumes. 4to, original matching green cloth-backed boards, lettered in black. xv, 298 + xv, 332 pages; 2 maps; genealogical tables; 17 + 22 fine plates. Very good or better. **\$200**

The classic works, with exceptional plates. Scarce. Clain-Stefanelli 9404* and 9257*.

An Inspiration for the Numismatist and the ANA

283 Nunn, C. Hearn [editor]. THE NUMISMATIC MAGAZINE. A MONTHLY JOURNAL DEVOTED ENTIRELY TO COIN COLLECTORS. Volumes II–V (Bury St. Edmund's, 1887–1889). Four volumes. 12mo, contemporary matching black cloth, gilt. (4), 96 + (4), 140 + (4), 140 + (4), 96 pages; occasional text illustrations. Moderate wear; still near fine. **\$200**

A scarce British publication, and apparently an influence on George Heath's publication of the same name founded in the United States but two years later. Nunn was the founder of the Numismatic Association, and the tone and general approach of the two publications is quite similar: serious in their devotion to the hobby, but at the same time chatty and a bit light. Nunn's earlier issues, preceding the Heath *Numismatist*, commented regularly on American numismatics. By the later volumes, Nunn seems to have allowed that area to fall under Heath's purview, and his *Numismatic Magazine* primarily focuses on British coins and medals.

The Aspers of Trebizond

284 Pfaffenhoffen, F. de. ESSAI SUR LES ASPRES COMNÉNATS, OU BLANCS D'ARGENT, DE TRÉBISONDE. Paris: Chez M. Rollin, 1847. 4to, original printed paper covers. 104 pages; 13 engraved plates of Trapezuntine coins; 4 additional plates, mainly of alphabets; large folding genealogical table of the emperors of Trebizond. Minimal foxing. Unopened and near fine. **\$200**

Infrequently encountered, especially well-preserved. Leitzmann 104.

Major Work on English Medals

285 (Pinkerton, John: generally ascribed to). THE MEDAL-LIC HISTORY OF ENGLAND TO THE REVOLUTION. First edition. London: Printed for Edwards and Sons, 1790. Folio [34 by 27.5 cm], contemporary tree calf boards, later rebacked in plain brown calf. iv, 112 pages; 40 engraved plates of medals. An ex-library copy, with ink stamps throughout. Binding worn; re-

backing amateurish. Very good or so. **\$120**

A notable 18th-century work on English medals. The preface notes that "This work is the first which lays before the Reader a complete series of English Medals down to the Revolution" and thanks Dr. Combe for the use of "his capital Collection of Prints and Drawings of English Medals" and for his "several explanations in the descriptions." Leitzmann 105 (listing the 1802 edition only, but giving the 1790 title). Manville 224. Ex Grimsby Public Library.

**The Mattei Collection of Decorations**

286 Platt, Clément. COLLECTION JOSE MATTEI. DÉCORATIONS: CROIX, MÉDAILLES, PLAQUES. MÉDAILLES D'HONNEUR ET DE SAUVETAGE RÉCOMPENSES OFFICIELLES. Paris, 24 mai 1912. Thin 4to, later quarter black calf and blue boards, gilt; original printed card covers bound in. 40 pages; 333 lots; 8 plates. Hand-priced in ink. Near fine. **\$100**
An important sale of decorations. Ex Richard E. Margolis Library.

Rare Sale of French Revolution Material

287 Platt, Clément, et al. COLLECTION TASBILLE (PREMIÈRE PARTIE) SUR LA RÉVOLUTION FRANÇAISE. Paris, 12–15 décembre 1938. 8vo, later maroon cloth and mottled boards, gilt. 70 pages; 4 fine plates. Last two pages badly torn, pages 67–68 missing with the last repaired showing lots 1101–1104 and 1111–1113. Prices realized report from newspaper laid in; some hand-pricing, with some names recorded. Good. **\$100**
Apparently complete for numismatic content and very rare. Ex Richard E. Margolis Library.

Scarce Marcel Platt Catalogues

288 Platt, Marcel. FIXED PRICE LISTS 14–22. Paris, 1957–1961. Includes lists numbers 14 (avril 1957), 15 (octobre 1957), 16 (mars 1958), 17 (octobre 1958), 18 (avril 1959), 19 (octobre 1959), 20 (mars 1960), 21 (décembre 1960), and 22 (avril 1961) bound in one volume. 8vo, later blue cloth printed in silver. Pages a bit browned; near fine. **\$100**
Scarce fixed price catalogues, primarily focusing on European coinage of the modern era, though some ancient and medieval content is to be found. Ex Richard E. Margolis Library.

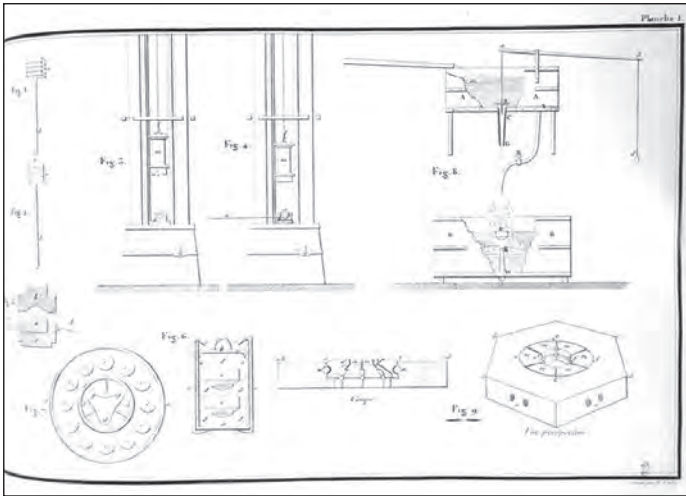

Photographic Reproduction of the 1803 Droz Report

289 Prony, et al. *RAPPORT FAIT A LA CLASSE DES SCIENCES MATHÉMATIQUES ET PHYSIQUES DE L'INSTITUT NATIONAL, SUR DIVERSES INVENTIONS DE JEAN-PIERRE DROZ, RELATIVES A L'ART DU MONNOYAGE*. Bound photographic reproduction of the original (Paris: Baudouin, Imprimeur de l'Institut National, Nivôse An XI [décembre 1802–janvier 1803]). Oblong 4to, later brown cloth, gilt. (4), 59, (1) pages; 4 plates (folded in original) signed by E. Collin, depicting coining presses and equipment, including Droz's segmented collar. Fine. **\$200**

An important publication, very rarely available. Matthew Boulton had this report translated into English for his own use. The plates are large and very interesting, being entirely devoted to coining technology, including the segmented collar Droz designed and which the Boulton firm continued to use even after it had been improved upon by James Lawson. This photographic reproduction was made for Richard Margolis by the Bibliothèque de l'Université, Paris. Ex Richard E. Margolis Library.

The Dr. Ratti Sale, &c.

290 Ratto, Rodolfo. *COLLEZIONI DEL DOTTOR LUIGI RATTI DI MILANO. PRIMA PARTE: MONETE E MEDAGLIE DELL'EPOCA NAPOLEONICA*. Milano, 30 Novembre 1910. Tall 8vo, later brown cloth, gilt; original printed card covers bound in. (4), 83, (1) pages; 1087 lots; 11 fine plates. Near fine. [with] Ratto, Rodolfo. *CATALOGO DI MEDAGLIE DI PERSONE ED AVVENIMENTI DELL'EPOCA NAPOLEONICA IN VENDITA ALL'ASTA AMICHEVOLE*. Genova, 18–19 Novembre 1903. 8vo, original printed rear paper cover (lacking front). 33, (1) pages; 545 lots. Wrinkled; good. **\$100**

The Ratti sale is very scarce and is well-illustrated. Ex Richard E. Margolis Library.

Waldo Newcomer Coins of the Americas

291 Raymond, Wayte, and J.G. Macallister [J.C. Morgenthau]. *THE WALDO NEWCOMER COLLECTION. PART I: GOLD AND SILVER COINS OF MEXICO, WEST INDIES, SOUTH AND CENTRAL AMERICA AND THE FAMOUS BRITISH COLUMBIA TEN AND TWENTY DOLLAR PIECES*. New York, February 12–13, 1935. Small 4to, later brown cloth, gilt;

original printed card covers bound in. 42, (2) pages; 744 lots; 12 plates. Original prices realized list bound in. Near fine. **\$100**
An important sale for Central and South American material, with especially impressive gold coins. The \$10 and \$20 British Columbian patterns are present in gold and silver. Adams 18 (rated A for the Americas, B+ overall). Ex Richard E. Margolis Library.

French Military Medals

292 Robert, P. Charles. *ÉVÉNEMENTS MILITAIRES ACCOMPLIS SOUS LE RÈGNE DE HENRI II DE 1551 À 1553 ET LEURS MÉDAILLES COMMÉMORATIVES*. Paris: Dumoulin, 1876. 8vo, original printed paper covers. 60 pages; 8 lithographic plates. Some staining, mostly to margins; very good. [with] Sculfort, Lieutenant. *DÉCORATIONS, MÉDAILLES, MONNAIES ET CACHETS DU MUSÉE DE L'ARMÉE*. Paris, 1912. 12mo, original printed card covers. (4), 348 pages; 5 hand-tinted lithographic plates. Near fine. **\$100**
The Sculfort volume is Suetens 147. Ex Richard E. Margolis Library.

Extensive Collection of European Medals

293 Roest, Th. M. *CATALOGUE DU CABINET NUMISMATIQUE DE LA FONDATION TEYLER À HAARLEM*. Harlem, 1909. Deuxième édition. 4to, later red buckram, gilt; original printed card covers bound in. (4), iii, (1), 516, (4) pages; 25 lithographic plates of medals. Near fine. **\$100**
A rarely encountered, detailed catalogue of this extensive collection of medals, mostly European medals of the 17th and 18th centuries. Includes a useful index arranged by medalist. Ex Richard E. Margolis Library.

Robinson Collection of Renaissance Medals

294 Rollin & Feuarent. *CATALOGUE DES MÉDAILLES ARTISTIQUES DE LA RENAISSANCE. COLLECTION FORMÉE PAR M. J.-C. ROBINSON*. Paris, 19–21 mai 1884. Small 4to, original printed paper covers. 73, (5) pages; 271 lots; 4 superb plates with tissue guards. Unopened. A couple of small chips to covers, else fine. **\$100**
Rare. The plates are exceptionally nice. Clain-Stefanelli 14375.

The Mouterde Family of Medalists

295 Rondot, Natalis. *LES GRAVEURS DU NOM DE MOUTERDE ET LE MONNAYAGE DU MÉTAL DE CLOCHE PUR À LYON*. Lyon: Imprimerie Pitrat Aîné, 1880. 4to, original printed card covers; cover and title page printed in black and red. viii, 134, (2) pages; 3 folding tables. Covers dusty with some wear; very good. **\$100**

A rather rare study of the Mouterde family of engravers. Cited in Forrer's *Biographical Dictionary of Medallists* in his coverage of several members of the family. Printed on fine paper in limited numbers. Ex Richard E. Margolis Library.

French Medals of the 15th–17th Centuries

296 Rouhette, Thierry, and Francesco Tuzio. *MÉDAILLES FRANÇAISES DES XV, XVI, XVII SIÈCLES*. Monaco: Éditions Victor Gadoury, 2008. Large 4to, original red cloth, gilt; jacket. 252, (2) pages; illustrated in color throughout. Near fine. **\$100**
An important and well-illustrated modern publication. Ex Richard E. Margolis Library.

Classic Work on British Coinage

297 Ruding, Rogers. *ANNALS OF THE COINAGE OF GREAT BRITAIN AND ITS DEPENDENCIES; FROM THE EARLIEST PERIOD OF AUTHENTIC HISTORY TO THE REIGN OF VICTORIA*. Third edition. London: Printed for John Hearne, 1840. Three volumes, complete. 4to, original matching blindstamped dark green pebbled cloth, gilt. xix, (3), 422; (2), 520; (2) pages; engraved dedication; folding table of gold coin weights; large folding map; plan of the Mint; 160 engraved plates of coins. Printed book description affixed to flyleaf; previous owner's signature. Spines worn, with some tears to cloth; joints cracked; intermittent foxing; very good. **\$250**

The best edition of this still indispensable documentary work. According to the prospectus the work was "To be published in Twenty-five Parts, as nearly as can be computed, price 5s. each Part." Publisher Hearne observes that "the object of the Author was to produce a grand comprehensive History of the Coinage of his native country" and concludes that "The Work, then, of which a new and improved Edition is proposed, is justly to be regarded as a National work. It is worthy of remark, that it is unique of its kind, no other country having so complete an account of its coinage." Clain-Stefanelli 9708.

An Antiquarian Work by Sainthill

298 Sainthill, Richard. *THE OLD COUNTESS OF DESMOND: AN INQUIRY, DID SHE EVER SEEK REDRESS AT THE COURT OF QUEEN ELIZABETH, AS RECORDED IN THE JOURNAL OF ROBERT SYDNEY, EARL OF LEYCHES-TER? AND DID SHE EVER SIT FOR HER PORTRAIT?* Dublin: Printed for Private Distribution Only at the University Press by M.H. Gill, 1861. First edition. 8vo, original brown blind-stamped cloth; spine lettered in gilt. 76 pages; large folding genealogical chart of the Earls of Desmond. Binding with minor scuffs and discolorations, but sound. Small tear to large folding chart. Very good or better. **\$250**

The first edition of a very scarce antiquarian work by this well-known Irish numismatist, privately printed in small numbers for distribution to the friends of the author. Inscribed and signed by the author, with authorial corrections to the text in ink. Sainthill (1787–1869) was a lawyer in Cork, Ireland, and was a close friend of numismatists Aquilla Smith and John Lindsay. Not numismatic, it focuses on the life of Katherine FitzGerald, Countess of Desmond, who became famous for her longevity. Now thought to have lived from about 1504 to 1604, she was thought by some to have been as much as 140 years old when she died. She lived in Inchiquin Castle, to which she had been granted a life tenancy by her husband, the Earl of Desmond. An interesting account by a most engaging author.

British Museum Catalogue of Japanese Coins

299 Sakuraki, Shin'ichi, Helen Wang, and Peter Kornicki. *CATALOGUE OF THE JAPANESE COIN COLLECTION (PRE-MEIJI) AT THE BRITISH MUSEUM*. London: British Museum, 2010. 4to, later black half morocco with blue cloth sides; spine with five raised bands, ruled and lettered in gilt; blue textured endpapers; page edges speckled in blue; original pictorial card covers bound in. vi, 218 pages; illustrated in color. Fine. **\$200**

A handsomely bound copy of this important British Museum catalogue, with fascinating historical background on the collection (and in particular on the significant role played by Kutsuki Masatsuna's collection in forming the Museum's cabinet) in addition to a thorough catalogue. Ex Alain Poinson Library.

Histories of the French Mints

300 Saulcy, F. de. *ÉLÉMENTS DE L'HISTOIRE DES ATELIERS MONÉTAIRES DU ROYAUME DE FRANCE DEPUIS PHILIPPE-AUGUSTE JUSQU'À FRANÇOIS I^{er} INCLUSIVE-MENT*. Paris: C. van Peteghem, 1877. 4to, original printed paper covers. vi, 168 pages. Unopened. Very nearly fine. **\$150**

A rare, but still-useful work, documenting the histories of the French mints, including personnel changes, orders affecting individual ateliers, production issues, etc. Engel & Serrure 5847: "Inventaire sommaire et chronologique des renseignements tirés des documents monétaires. Les ateliers dont l'histoire est indiquée sont : Agen, Aisse, Aix-en-Provence, Amiens, Angers, Angoulême, Arras, Auxerre, Auxonne, Bayonne, Beaucaire, Beauvais, Bordeaux, Bourges, Briançon, Bruges, Carcas-sonne, Châlons-sur-Marne, Chalon-sur-Saône, Chambéry, Château-Thierry, Chaumont, Chinon, Condom, La Côte-Saint-André, Crémieu, Le Crotoy, Dijon, Embrun, Figeac, Fontenay, Fourras, Grenoble, Guise, Laon, La Rochelle, Le Mans, Le Puy, Lille, Limoges, Loches, Loviguen, Lyon. Mâcon, Marseille, Marvejols, Massères, Melun, Mirabel, Montai-gu, Mont-de-Dôme, Montdidier, Montelimar, Montferrand, Montignat, Montpellier, Montreuil-Bonin, Mont-Saint-Michel, Mouzon, Nantes, Nevers, Nîmes, Niort, Nontron, Notre-Dame-du-Bois, Orléans, Pam-iers, Paris, Parthenay, Périgueux, Perpignan, Poitiers, Pont-Saint-Esprit, Rennes, Rocheguide, Romans, Rouen, Saint-André-lès-Avignon, Saint-Antonin, Saint-Cyr, Saint-Gengoulf, Saint-Georges-d'Espérance, Saint-Laurent, Saint-Lô, Sainte-Menehould, Saint-Pourçain, Saint-Quentin, Salins, Saumur, Sens, Sommières, Tarascon, Termère, Toulouse, Tournai, Tours, Troyes, Turin, Vannes, Villefranche de-Rouergue et Ville-neuve."

**Attractive Copy of Saulcy on the 1848 Revolution**

301 Saulcy, Louis Félicien Joseph Caignart de. *SOUVENIRS NUMISMATIQUES DE LA RÉVOLUTION DE 1848. RECUEIL COMPLET DES MÉDAILLES, MONNAIES ET JETONS QUI ONT PARU EN FRANCE DEPUIS LE 22 FÉVRIER JUSQU'AU 20 DÉCEMBRE 1848*. Paris: chez J. Rousseau, (1848–1850). 4to, dark blue full morocco; sides paneled in blind; spine ruled, lettered and richly decorated in gilt; marbled endpapers. (4), 111, (1) pages; 60 finely engraved lithographic plates. Professionally rebacked, with original spine and later sides. Marginal foxing to plates; near fine. **\$300**

A well-preserved large-paper copy of this very scarce work, in a handsome binding. Clain-Stefanelli 14547. Engel & Serrure 5790. Grierson 262. Ex Rollin & Feuarent Library.



Biographical Study of Augustin Dupré

302 Saunier, Charles. **AUGUSTIN DUPRÉ: ORFÈVRE, MÉDAILLEUR ET GRAVEUR GÉNÉRAL DES MONNAIES.** Paris: Société de Propagation des Livres d'Art, 1894. 4to, contemporary tan half calf with marbled sides, gilt; spine with five raised bands, ruled, lettered and decorated in gilt; decorative endpapers. xiv, (2), 120 pages; text illustrations, some full page; 6 very fine plates of medals. Occasional spotting; else fine. **\$400**

A superior copy of this rarely offered work on an important French medalist and coin engraver, best known for his work on post-Revolutionary French coinage and on several exceptionally important early American medals, most notably the Libertas Americana medal. Clain-Stefanelli 13565.

Extensive Collection of Peace Medals

303 Schulman, J. **COLLECTION LE MAISTRE. PAX IN NUMMIS: MÉDAILLES, JETONS ET MONNAIES AYANT RAPPORT AUX DIVERS TRAITÉS DE PAIX CONCLUS DEPUIS LE XVI^e SIÈCLE JUSQU'À NOS JOURS.** Amsterdam, 1912. Small 4to, original printed white card covers. (4), 277, (1) pages; text illustrations; 1106 listings; 12 halftone plates. A bit worn at spine; still near fine. **\$100**

The largest collection of its kind ever formed. Scarce and still important. Illustrates far more of the medals than the later auction catalogue.

Coins & Medals at Mannheim

304 Seubert, Max von. **VERZEICHNIS DER IN DER SAMMLUNG DES MANNHEIMER ALTERTUMSVEREINS BEFINDLICHEN PFÄLZISCHEN UND BADISCHEN MÜNZEN U. MEDAILLEN. KATALOGE. NEUE FOLGE. BAND I.** Mannheim: im Selbstverlag des Altertumsvereins, 1900. 8vo, contemporary green cloth, gilt; page edges speckled. (2), 214 pages; 6 fine plates. Near fine. **\$100**

A catalogue of the coins and medals comprising the collection of the Mannheimer Altertumsverein. Infrequently offered. Ex Richard E. Margolis Library.

Reprints & Translations of Works on Russian Coins

305 Severova, M.V. **LA LITTÉRATURE NUMISMATIQUE DANS LA RUSSIE DU XVIII^e SIÈCLE. BIBLIOGRAPHIE ANNOTÉE 1710–1800. APERÇU GÉNÉRAL.** Translation into French by François van Hoof of the Leningrad, 1982 original.

4to, original dark blue leatherette, gilt. 58, (2) leaves. Fine. [with] Ouzdenikov, V.V. **MONNAIES RUSSES, 1700–1917.** Translation into French by François van Hoof and Andre Schoevaert of the Moscow, 1985 first edition. Two volumes. 4to, original matching green leatherette, gilt. 433, (1) pages plus plate volume of approximately 200 leaves; errata sheet. Near fine. [with] Smirnov, V.P. **DESCRIPTION DE MÉDAILLES RUSSES 862–1908 (AVEC SUPPLÉMENT).** Russian Numismatic Society, 1990. Translation into French by François van Hoof and Andre Schoevaert of the 1908 original. 4to, original red cloth and printed boards, lettered in gilt. (2), 641, (1) pages. Fine. [with] van Hoof, François. **RUBLES 1897–1898–1899 STRUCK AT THE BRUSSELS MINT. REPORT FROM OFFICIAL DOCUMENTS.** Given by the author at the December 11, 1988 meeting of the Russian Numismatic Society at the New York International Numismatic Convention. 8.5 by 14 pages, stapled with printed card covers. (44) pages. Fine. **\$120**

Important works, generally distributed noncommercially through the Russian Numismatic Society in the 1980s. The first is a notable bibliography of 18th-century Russian numismatic works. Uzenikov (as the name is generally transliterated into English) is one of the most important modern works on Russian coins. V.P. Smirnov's 1908 *Описание русских медальей* is the classic work on Russian medals, and originals are very rare. Ex Richard E. Margolis Library.

The Montague Guest Collection

306 Smith, Reginald A. [editor]. **CATALOGUE OF THE MONTAGUE GUEST COLLECTION OF BADGES, TOKENS AND PASSES PRESENTED IN 1907 TO THE DEPARTMENT OF BRITISH AND MEDIAEVAL ANTIQUITIES.** London: British Museum, 1930. 8vo, original blue cloth, gilt. viii, (2), 206 pages; table; 8 fine plates. Fine. **\$100**

First and only edition. A charming publication, useful and scarce. Ex Richard E. Margolis Library.

The Matthew Young Edition of Snelling

307 Snelling, T. **SNELLING ON THE COINS OF GREAT BRITAIN AND IRELAND, ETC. IN DETACHED PIECES, AS FOLLOWS:**

- I: GOLD COIN AND COINAGE OF ENGLAND... 1763. (2), (2), iv, 36 pages.
- II: SILVER COIN AND COINAGE OF ENGLAND... 1762. (2), 55, (1) pages.
- III: COPPER COIN AND COINAGE OF ENGLAND... 1766. (4), 46, 6 pages.
- IV: SILVER COIN AND COINAGE OF SCOTLAND... 1774. (4), 20 pages.
- V: GOLD SILVER ETC. COINS STRUCK IN FRANCE ... BY THE EAST INDIA COMPANY.. ... IN THE WEST INDIA COLONIES... 1769. (4), 53, (1) pages.
- VI: IRISH COINS IN SILVER AND COPPER... No date of publication. 8 pages.
- VII: ORIGINS, NATURE AND USE OF JETTONS OR COUNTERS... 1769. (2), 2, 16 pages.

London: Sold by the Proprietor, M. Young, 1823. Seven works in one volume, with six separate title pages and 70 attractively

engraved copper plates of coins and tokens. Folio, somewhat later brown quarter morocco with decorative sides; tan spine label, lettered in gilt. Binding lightly rubbed, but sound. A near fine copy. **\$250**

A well-preserved example of this scarce collected edition published by dealer Matthew Young (more commonly seen is the J. Thane edition, published sometime after 1774). Thomas Snelling was one of the principal London coin dealers of his day and was, needless to say, a prolific author. This appears to be the second collected edition of all of his major works, which were influential and of considerable significance at the time. The fifth work is justly famous for including 18th-century engravings of American colonial coins including Massachusetts silver. This copy is larger than usually seen (it was only slightly trimmed in binding) and has no serious faults.

French Society's Annual for 1888

308 Société Française de Numismatique et d'Archéologie. ANNUAIRE DE LA SOCIÉTÉ FRANÇAISE DE NUMISMATIQUE ET D'ARCHÉOLOGIE. TOME DOUZIÈME ANNÉE 1888. (Paris): au Siège de la Société, 1888. 4to, contemporary black quarter morocco; spine with five raised bands, ruled and lettered in gilt. 592, 15, (1) pages; portrait of Gustave de Ponton d'Amécourt; text illustrations; 5 plates. Some pages foxed, few tape repairs, binding worn at edges; very good. **\$100**

A rare and important publication featuring scholarly papers, principally on medieval and modern French coins as well as ancient coins. The society was founded by Viscount Gustave de Ponton d'Amécourt, who served as first president and was a member of the publication committee, along with Caron, Sabatier, Marchant, and Gariel. Clain-Stefanelli 359. Engel & Serrure 71. Grierson 16. Ex Richard E. Margolis Library.

Essays on Swiss Coinage

309 Société Suisse de Numismatique. MONNAIES AU PAYS DE VAUD. Berne, 1964. 8vo, later olive cloth, green leather spine label, gilt; original card covers bound in. 151, (1) pages; 22 plates. Fine. **\$100**

A scarce collection of essays. *Bibliothèque Historique Vaudoise* XXXVIII. Ex Richard E. Margolis Library.

Handsomely Bound Medals Sale

310 Sotheby, Wilkinson & Hodge. CATALOGUE OF MEDALS & PLAQUETTES OF THE ITALIAN RENAISSANCE, BRITISH AND OTHER COMMEMORATIVE MEDALS... London, 10–11 May 1921. Crown 4to, later green quarter morocco; spine lettered in gilt. 55, (1) pages; 368 lots; 5 fine plates. Fine. **\$100**

The R.C. Fisher collection, with additional material from the collections of Canon Millard, S.M. Milne, and Talbot Ready. Ex Richard E. Margolis Library.

The Marquess of Bute Catalogues

311 Sotheby & Co. CATALOGUE OF THE FIRST/SECOND/THIRD PORTION OF THE FINE AND IMPORTANT COLLECTION OF ENGLISH, SCOTTISH, IRISH AND FOREIGN COINS ... COMMEMORATIVE MEDALS... THE PROPERTY OF THE MOST HONBLE. THE MARQUESS OF BUTE. [titles vary] London, 7–8 May, 11 June, and 2 July 1951. Three catalogues, complete, bound in one volume. Crown 4to,

later green cloth, gilt. 31, (1)+ 36 + 32 pages; 351 + 327 + 223 lots; 5 + 9 + 11 fine plates. Fine. **\$100**

Especially noteworthy for Scottish coins and the series of historical medals. Scarce. Ex Richard E. Margolis Library.

The 1954 Farouk Sale

312 Sotheby & Co. THE PALACE COLLECTIONS OF EGYPT. CATALOGUE OF THE HIGHLY IMPORTANT AND EXTREMELY VALUABLE COLLECTION OF COINS AND MEDALS, THE PROPERTY OF THE REPUBLIC OF EGYPT. Cairo, February 24–March 6, 1954. Crown 4to, original printed card covers. 306, (6) pages; 2798 lots; 37 plates, all but the last double-plates. Spine hand-lettered; near fine. **\$200**

The famous sale catalogue of the legendary coin collection formed by King Farouk. The details surrounding the sale are fascinating and often bizarre, and were recounted in part by Abe Kosoff in a series of *Coin World* articles. Dominated by Kosoff, Hans Schulman and a handful of other East Coast coin dealers, only a few collectors attended the sale, John J. Pittman notably among them. Catalogued by the London firm of Baldwin's, great rarities from the Woodin, Earle, Colonel Green and other great American collections were often placed in group lots, e.g., a 1913 Liberty Head nickel and pattern United States gold coins. The onerous financial requirements imposed by the Egyptian Government combined with reported dealer collusion appears to have stifled widespread competition and many bargains were to be had by those brave enough to venture to Cairo. Clain-Stefanelli 8013*. Grierson 275 and 277.

Major Canadian Sales

313 Sotheby & Co. (Canada), Ltd. CATALOGUE OF COINS AND MEDALS FROM THE COLLECTION OF CANADIANA FORMED BY THE LATE ROBERT W. REFORD OF MONTREAL... Toronto, October 30, 1968. [bound with] CATALOGUE OF CANADIAN COINS, TOKENS AND MEDALS FROM THE COLLECTION FORMED BY RICHARD WELLINGTON WILLIAMS... Toronto, April 23, 1969. [bound with] Sotheby & Co. (Canada), Ltd. CATALOGUE OF CANADIAN COINS AND TOKENS, COMMEMORATIVE AND WAR MEDALS. Toronto, October 28, 1969. [bound with] CATALOGUE OF CANADIAN COINS, TOKENS AND BANKNOTES, COMMEMORATIVE, WAR AND INDIAN PEACE MEDALS, INDIAN TRADE SILVER. Toronto, May 26, 1970. Four illustrated catalogues. 4to, later black cloth, gilt; original pictorial card covers bound in. All with named prices realized lists laid in. Fine. **\$100**

Important Canadian sales, strong in medals, Breton tokens and paper money. Ex Richard E. Margolis Library.

Margolis's Annotated Tiktin Sale

314 Sotheby's. TIKTIN COLLECTION: NAPOLEONIC [spine title]. New York, July 16, 1981. Square 8vo, later gray cloth, gilt. Lots 209–367 only; text illustrations. Prices realized in pencil next to each lot; annotated by Richard Margolis. Fine. **\$100**

Richard Margolis's substantially annotated copy of the pages from this catalogue including the Napoleonic Coins and Medals from the Collection of the Late Rudolph Tiktin. Ex Richard E. Margolis Library.

First Edition of Spahr

315 Spahr, Rodolfo. *LE MONETE SICILIANE DAGLI ARAGONESI AI BORBONI (1282–1836)*. Palermo, 1959. First edition. 4to, original green cloth, gilt, plates housed loosely in a special pocket at the end. (8), 296, (8) pages; genealogical tables; 39 fine plates. A bit shaken; very good. **\$100**
Still an important resource. Clain-Stefanelli 10418*.

Medallic History of the Palatinate

316 Stemper, Annelise. *DIE MEDAILLEN DER PFALZGRAFEN UND KURFÜRSTEN BEI RHEIN: PFÄLZISCHE GESCHICHTE IM SPIEGEL DER MEDAILLE. TEIL I: DIE KURLINIEN. TEIL II: DIE NEBENLINIEN*. Worms: Werner-sche Verlagsgesellschaft, 1997. Two volumes, complete. Tall 4to, original matching blue cloth lettered in silver. xlvi, 605, (1) + (6), 607–967, (1) pages; illustrated throughout. Near fine. **\$100**
A remarkably thorough and handsomely presented work.

Major Work on Ottoman Coins

317 Sultan, Jem [William D. Holberton]. *COINS OF THE OTTOMAN EMPIRE AND THE TURKISH REPUBLIC. A DETAILED CATALOGUE OF THE JEM SULTAN COLLECTION*. Thousand Oaks: B&R, 1977. Two volumes. 8vo, original green leatherette, gilt; housed in matching slipcase, as issued. xxv, (1), 457, (1); ix, (13) pages; 353 plates. Signed and numbered by the author. Slipcase worn, but volumes fine. **\$200**
The catalogue of one of the finest collections of Ottoman and Turk coinage ever assembled, now in the collections of the American Numismatic Society. Important. One of 500 sets issued, numbered by the author. Clain-Stefanelli 11856.

Works on British Tokens

318 Todd, Neil B. *SEVEN WORKS ON TOKENS, GENERALLY OF GREAT BRITAIN*. As follows: *A Note on the So-Called "Spade" Guinea and Half Guinea Counters* (1969 typescript); *British Tokens, Advertising Tickets, Checks, Passes, etc., ca. 1830 to 1920* (1974); *Dublin Tavern Tokens of the Latter Half of the 19th Century* (1977); *British & Irish Tokens, Advertising Tickets, Checks, Passes, &c. ca. 1830–1920* (1979); *A Catalogue of Borough Market Tallies* (1986); and *A Catalogue of Covent Garden Market Tallies* (1987). Seven titles, bound in one volume. 4to, later gray cloth, gilt; original printed card or paper covers bound in where issued. Fine. **\$100**
Several specialized titles, brought together in one volume. Ex Richard E. Margolis Library.

The Belgian Royal Collection of Medals

319 Tourneur, V. *CABINET DES MÉDAILLES. CATALOGUE DES MÉDAILLES DU ROYAUME DE BELGIQUE. TOME PREMIER: 1830–1847*. Bruxelles, 1911. Tall 8vo, later light brown faux leather with decorative sides; spine with fine raised bands, ruled and lettered in gilt; original printed card covers bound in. lxvii, (1), 254, (2) pages; frontispiece portrait; 34 fine plates. Spine taped and worn; very good or so. **\$100**
This first volume was all that was published. Clain-Stefanelli 14437. Ex Richard E. Margolis Library.



With Plates Engraved via Medal Ruling Machine

320 Toussenet, Théodore. *PRÉCIS CHRONOLOGIQUE DE L'HISTOIRE DE FRANCE, POUR SERVIR DE TEXTE EXPLICATIF AUX PLANCHES GRAVÉES SUR ACIER PAR LE PROCÉDÉ COLLAS, D'APRÈS LA COLLECTION DES MÉDAILLES HISTORIQUES DES ROIS DE FRANCE, DONT LES COINS SONT DÉPOSÉS À LA MONNAIE ROYALE DE PARIS*. Paris, 1844. 4to, original green decorative cloth, gilt. (12) pages; 4 double-page plates engraved by medal-ruling machine, with tissue guards, bound in on hinges, illustrating 72 medals. Foxed. Very good. **\$100**

A very scarce work providing descriptions of the 72 medals illustrated using this innovative technique, perfected in France by Achille Collas. They were engraved with a pantographic ruling machine and, in addition to being of great visual appeal, the illustrations were the most accurate ever achieved. This technical innovation, widely heralded at the time, was, within a few decades, overtaken by photographic printing processes and is relatively little known today.

Medallic Portraits of Simon Bolivar

321 Urdaneta Braschi, Ezequiel. *BOLIVAR EN LA NUMISMATICA CONMEMORATIVA Y EN LAS CONDECORACIONES*. Caracas: Banco Central de Venezuela, 1983. 4to, original red boards, gilt; jacket. 320, (8) pages; heavily illustrated throughout, including depictions of historical medals and orders and decorations, a great many in full color. Near fine. **\$100**
A lavish production, published on the "año bicentenario del nacimiento del libertador." Ex Richard E. Margolis Library.

Classic Work on Ypres, in a Presentation Binding

322 Vandenpeereboom, Alphonse. *ES-SAI DE NUMISMATIQUE YPROISE*. Bruxelles: Fr. Gobbaerts, 1877. Tall 4to [31 by 23 cm], original red half morocco with double gilt fillets; spine with five raised bands, ruled, and richly decorated in gilt, with presentation lettering to I. Diegerick (see comments); marbled sides and endpapers; top page edges gilt. (4), 378 pages; 42 engraved plates signed by P. de Cleermaecker. Binding rubbed at extremities; occasional browning

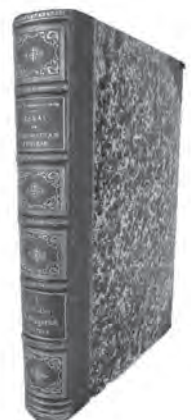

Vredius on Flemish Sigillography & Genealogy

329 Vredius, Olivarius. *SIGILLA COMITUM FLANDRIÆ ET INSCRIPTIONES DIPLOMATUM AB IIS EDITORUM CUM EXPOSITIONE HISTORICA*. Brugis Flandrorum: Apud Joannem Baptistam Kerchovium, 1639. First edition. Title with large engraved illustration of a seal; (12), 308, (96) pages; woodcut decorations and initials; finely engraved two-thirds page map; finely engraved genealogical chart; finely engraved plate depicting 70 European coats of arms; hundreds of superbly engraved seals, many quite large, interspersed throughout the text. [*preceded by*] Vredius, Olivarius. *GENEALOGIA COMITUM FLANDRIÆ A BALDUINO FERREO USQUE AD PHILIPPUM IV. HISP. REGEM...* Brugis Flandrorum: Apud Joannem Baptistam & Lucam Kerchovios, 1642. Title with large engraved illustration of a seal; (16), 170, (2) pages; woodcut decorations and initials; hundreds of superbly woodcut seals, many quite large, interspersed throughout the text. [*bound with*] Vredius, Olivarius. *HISTORIÆ FLANDRIÆ CHRISTIANÆ. AB ANNO CHRISTI 500. CLODOVÆI I. FRANCORUM REGIS XVI. USQUE AD ANNUM 767. PEPINI REGIS FRANC. XVI.* Brugis Flandrorum: Typis Petri van Pee, undated. Title with woodcut printer's device; (2), 298, (2) pages; woodcut headpiece and initial. Three works bound in one volume. Folio [31 by 21 cm], full contemporary vellum; both sides embossed with central decorative device; spine with seven raised bands, lettered in in; all paper edges speckled red. Final work browned with some evidence of damp-staining; the two illustrated sigillographic works are mostly bright and clean, with only occasional spotting or browning. Vellum somewhat darkened, particularly at spine. Near fine. **\$750**

Olivarius Vredius (1596–1652), also known as Uredius, or Olivier de Wree, was a jurist and *poète brugeois*, well-known for his deep involvement in archeology, history, and numismatics. His work on the seals of the counts of Flanders is a most handsomely produced work and is quite rare. As Engel and Serrure observe, it also includes information on the coins. Brunet 25079. Cumont 2139. Dekesel V91 (first two parts). Engel & Serrure 6537: "Renferme quelques monnaies de Flandre." Graesse 402. Ex Swann Galleries (April 2, 1989), lot 369.



and other signs of age. Very good or better. Laid in are several association items, including: a duplicated 1877 letter from the author presenting this work; a May 1879 newspaper review of Vandenpeereboom's *Notices, études, notes et documents sur Ypres* (1879); a menu ("pour 500 couverts") printed in red and gold, of an 1868 dinner given in honor of the author; and an engraved letter dated 1 août 1885 from the executor of Vandenpeereboom's estate forwarding a lithographic portrait of the late numismatist, which is also included. **\$300**

One of 25 large-paper copies printed on papier royal. First published in various volumes of the *Revue belge de numismatique*, Vandenpeereboom's *Essai* remains the classic work on the numismatic history of Ypres. The author (1812–1884) was a Minister of State, President of the Société archéologique d'Ypres, and an active member of the Société royale belge de numismatique. His seven-volume *Ypriana* was published between 1878 and 1883 and drew extensively upon his personal collections of manuscripts, documents, coins and other material artefacts of Ypres. Bequeathed to the city, his collections were destroyed during the First World War. This copy was bound for the author's colleague Isidore Diergerick, a fellow member of many of the historical societies in which Vandenpeereboom was active. Cumont 2014.

The Baroque Medal in Tuscany

323 Vannel, Fiorenza, and Giuseppe Toderi. *LA MEDAGLIE BAROCCA IN TOSCANA*. Firenze: Studio per Edizioni Scelte, 1987. Folio [34 by 25 cm], original gray cloth, gilt; jacket. 316, (4) pages; occasional text illustrations; 149 fine plates. Near fine. **\$100**

A superb publication, providing biographical information on the medallists included and a well-illustrated corpus of 17th and 18th-century Tuscan medals. Ex Richard E. Margolis Library.

Works on Portuguese Coins & Medals

324 Various. *SEVERAL WORKS ON PORTUGUESE COINS AND MEDALS*. Includes: J. Sabatier's 1868 *Rapport sur la collection royale des monnaies portugaises figurant a l'exposition universelle de 1867...*; the 1949 reissue of J. Schulman's *Les monnaies des colonies portugaises de la collection importante H. T. Grogan*; J. Ferraro Vaz's 1948 *Catálogo das moedas portuguesas*; and Alberto Gomes's 1992 *Moedas portuguesas na Época dos Descobrimentos, 1385–1580*. Varying formats. Very good to fine. **\$100**

Includes some important works. The 1868 Sabatier publication is quite rare. Ex Richard E. Margolis Library.

Reprint Set of Vidal Quadras y Ramón

325 Vidal Quadras y Ramón, Manuel. *CATÁLOGO DE LA COLECCIÓN DE MONEDAS Y MEDALLAS DE MANUEL VIDAL QUADRAS Y RAMÓN DE BARCELONA. TOMO PRIMERO-TOMO CUARTO*. 1975 Valencia reprint of the original 1892 Barcelona publication. Four volumes. 4to, original printed card covers. 1492 pages; 87 plates of coins and medals. Near fine. **\$100**

The useful reprint of this massive work. Originals have been considered scarce virtually from the time of publication. Don Manuel Vidal Quadras y Ramón (1818–1894) was a well-known and highly respected banker in Barcelona, and his collection of Spanish coins and medals is one of the most comprehensive and finest ever formed. Sold privately, this indispensable work is the only published record of his magnificent holdings. Clain-Stefanelli 11410*. Grierson 169. Mateu y Llopis 20.

Important Sale of French Royal Coins

326 Vinchon, Jean. *COLLECTION C.G. DE P.M. DE RIO DE JANEIRO. TRÈS IMPORTANTE COLLECTION DE MONNAIES EN OR ROYALES FRANÇAISES DEPUIS PHILIPPE IV LE BEL JUSQU'À LOUIS XVI...* Paris, 19–20 février 1962. 4to, later brown quarter morocco; spine lettered in gilt; original pictorial card covers bound in. 633 lots; 22 fine plates. *Supplément* bound in containing lots 634–646. Estimates list and sale announcement postcard laid in. Fine. **\$100**

An attractively bound copy of this significant sale. Ex Richard E. Margolis Library.

Vlack on French Colonials Used in the Americas

327 Vlack, Robert A. *AN ILLUSTRATED CATALOGUE OF THE FRENCH BILLON COINAGE IN THE AMERICAS*. N.p.: Colonial Coin Collectors Club, 2004. 4to, original blue cloth lettered in silver. x, 157, (1) pages; illustrated. Fine. **\$100**

The standard work, now out of print. Ex Richard E. Margolis Library.

Classic Work on Prussian Coins

328 Vossberg, F.A. *GESCHICHTE DER PREUSSISCHEN MÜNZEN UND SIEGEL VON FRÜHESTER ZEIT BIS ZUM ENDE DER HERRSCHAFT DES DEUTSCHEN ORDENS*. Berlin: bei G. Fincke, 1843. 4to, contemporary black cloth-backed boards; hand-lettered spine label. vi, 216 pages; tables; text illustrations; 20 engraved plates of coins and seals. Half-title loose; binding a bit worn. Very good. **\$200**

An important work by this esteemed German scholar. Rare: this is the first complete copy we've handled since our 1988 New York Book Auction. Clain-Stefanelli 6994. Grierson 144. Gumowski 3240. Ex Bibliothek der Firma Schulman (1995 Frankfurter Münzhandlung sale, lot 779).

The Tokens of South London

330 Waters, Arthur W. *THE TOKEN COINAGE OF SOUTH LONDON ISSUED IN THE 18TH AND 19TH CENTURIES. WITH INTRODUCTION AND NOTES*. Leamington Spa: Simmons & Waters, 1904. Small 8vo, original maroon quarter morocco, gilt; spine lettered in gilt; top page edges gilt. Frontispiece portrait; xiv, 33, (1) pages; 2 fine autotype plates of tokens; folding facsimile; 3 lithographic plates. Inscribed by the author to Fred Shaw & Co. Spine worn, particularly at base; contents fine. Very good. **\$250**

One of only 100 copies printed. A scholarly and at times entertaining es-

say on this interesting numismatic backwater, leavened by some marvelously obscure literary and historical references. A total of fifty-four tokens are described. The inscription is dated January 13, 1904. Davisson, *Handbook*: "This is a detailed discussion of these pieces including news reports and material written at the time the tokens were issued." Manville 629.

Medals Relating to England

331 Weber, F. Parkes. *MEDALS AND MEDALLIONS OF THE NINETEENTH CENTURY, RELATING TO ENGLAND, BY FOREIGN ARTISTS*. London, 1894. 8vo, original maroon cloth, gilt. vi, (2), 128 pages; 2 very fine plates. Spine taped; final signature loose; very good. **\$100**

Very scarce. Ex Richard E. Margolis Library.

Alain Weil Sale Catalogues

332 Weil, Alain. *PARIS SALES (1978–1979)*. Spine title cited. Seven illustrated catalogues bound together, dated: 9 mai 1978; 5 juin 1978; 15 décembre 1978; 8 février 1979; 23 avril 1979; 20 juin 1979 and 26 novembre 1979. Prices realized lists or clipped articles included with each catalogue. 8vo, later gray cloth. Near fine or better. [with] Weil, Alain. *PARIS SALES (1980–1981)*. Spine title cited. Six illustrated catalogues bound together, dated: 26 mars 1980; 16 juin 1980; 6 octobre 1980; 25 mars 1981; 3 juillet 1981; and 2 décembre 1981. 272 lots; 7 plates. Prices realized lists or clipped articles included with each catalogue. 8vo, later gray cloth. Near fine or better. **\$100**

Useful catalogues, infrequently offered. Ex Richard E. Margolis Library.



Sebastian Dadler

333 Więcek, Adam. *SEBASTIAN DADLER: MEDALIER GDAŃSKI XVII WIEKU*. Gdansk, 1962. 4to, later half black morocco with blue cloth sides; spine with five raised bands, ruled and lettered in gilt; blue textured endpapers; all page edges speckled blue; original pictorial card covers bound in. 146, (2) pages, entirely bound in on hinges; numerous text illustrations; 54 plates of medals. Light rubbing to binding; near fine. **\$200**

Important and very scarce, in a later half morocco binding. Clain-Stefanelli 14652. Ex Alain Poinsignon Library.

Withers on Coin Weights

334 Withers, Paul and Bente. *BRITISH COIN-WEIGHTS: A CORPUS OF THE COIN-WEIGHTS MADE FOR USE IN ENGLAND, SCOTLAND AND IRELAND*. Llanfyllin: Galata, 1993. Tall 4to, original maroon cloth, gilt. (2), 366 pages; illustrated throughout. Price guide and prospectus laid in, as are photocopied notes on Irish weights. Near fine. **\$100**

The standard work. Ex Richard E. Margolis Library.

Works on British Coinage

335 Withers, Paul and Bente Romlund. MONOGRAPHS. Llanfyllin: Galata, 1995–2004. Includes: *Lions, Ships And Angels: Identifying Coin-Weights Found In Britain*; *Halfpennies and Farthings: Edward I and II*; *Halfpennies and Farthings: Edward III and Richard II*; *Halfpennies and Farthings: Henry IV, V and VI*; *Small Silver: Henry VIII–The Commonwealth*; and *Halfpennies and Farthings: Edward IV–Henry VII*. [with] Wren, Christopher R. MONOGRAPHS. Kent: Plantagenet, 1992–1995. Includes: *The Short-Cross Coinage 1180–1247: Henry II to Henry III*; *The Voided Long-Cross Coinage 1247–1279: Henry III & Edward I*; and *The English Long-Cross Pennies 1279–1489: Edward I to Henry VII*. [with] Briggs, Norman. ENGLISH WEIGHTS: AN ILLUSTRATED SURVEY. Llanfyllin: White House, 1992. Ten titles total. All 12mo, original printed card covers. One volume with some loose leaves. Generally fine. **\$100**

Fine series of specialized monographs on British coins.

Withers on Copper Tokens

336 Withers, Paul and Bente R. BRITISH COPPER TOKENS, 1811–1820, INCLUDING THOSE OF IRELAND, THE ISLE OF MAN AND THE CHANNEL ISLANDS. Llanfyllin,

1999. 4to, original green cloth, gilt. 264 pages; well illustrated throughout. Fine. **\$100**

An indispensable work on nineteenth-century British tokens, whose coverage includes a number of tokens collected in the Canadian series. Ex TAB Library.

Wurzbach-Tannenberg's Medal Cabinet

337 Wurzbach-Tannenberg, Dr. Wolfgang R. v. KATALOG MEINER SAMMLUNG VON MEDAILLEN, PLAKETTEN UND JETONS ZUGLEICH EIN HANDBUCH FÜR SAMMLER. Hamburg, 1978 reprint. Two volumes, complete. Thick 8vo, original matching tan cloth; red leather spine labels, gilt. Frontispiece; xv, (1), 758; (4), 759–1642, (2) pages; 16 plates. Spine labels partly detached; near fine. **\$100**

Clain-Stefanelli 14142: "Good reference on medals of poets and writers." Ex Richard E. Margolis Library.

Modern Work on Napoleonic Medals

338 Zeitz, Lisa, and Joachim Zeitz. NAPOLEONS MEDAILLEN. Petersberg: Imhof, 2003. Folio [32.5 by 24.5 cm], original pictorial boards; jacket. 288 pages; extensively illustrated in color. Fine. **\$100**

A well-illustrated work, with many full-color enlargements. Examines the medals of Napoleon as important aspects of his propaganda machine. Ex Richard E. Margolis Library.

UNITED STATES NUMISMATICS

Abe Kosoff's Annotated Adams & Woodin

Recording Coins in the Woodin, Newcomer, Green & Boyd Collections

339 Adams, Edgar H., and William H. Woodin. UNITED STATES PATTERN, TRIAL, AND EXPERIMENTAL PIECES. BEING A LIST OF THE PATTERN, TRIAL AND EXPERIMENTAL PIECES WHICH HAVE BEEN ISSUED BY THE UNITED STATES MINT FROM 1792 UP TO THE PRESENT TIME. New York: ANS, 1913. 8vo, original blue cloth, gilt; decorative endpapers. (8), 196 pages; text illustrations. Heavily annotated throughout, with writing on nearly every page, in multiple colored pencils. Binding very worn, with some signatures loose. Good. **\$1500**

A very important copy of this landmark work. Based on Woodin's extensive holdings, the Adams-Woodin compilation was a quantum leap over what little had previously been published on patterns. For half a century, it remained the standard reference on these fascinating pieces. This copy has been heavily annotated by Abe Kosoff, who was intimately involved with the development of the Judd pattern book that took the AW volume's place as the standard work on the subject. The annotations are mostly in blue and red pencil, with blue indicating those pieces in the Newcomer-Boyd collections, and the red indicating those derived from the Woodin-Newcomer-Green-Boyd pedigree chain. Other known examples are recorded, usually in regular pencil, along with prices. Entries are crossed out where erroneous, and additional information added where necessary. On the front flyleaf are notes on the diagnostic fea-

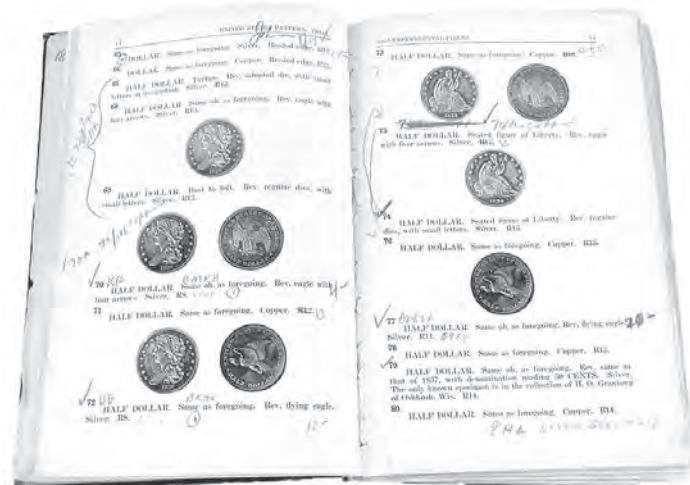

tures of 1804 dollars, while the verso of the rear flyleaf includes a listing of the pieces dated 1883 and 1884 struck at the Philadelphia Mint for the Kingdom of Hawaii. This copy has been in the same hands since 1983, when it was purchased at Jack Collins's first numismatic literature sale; Kosoff's second annotated copy, also included in that sale, was sold to Armand Champa. Of considerable importance to the student of U.S. pattern coinage. Ex Jack Collins's October 1, 1983 sale (lot 319 at \$875 hammer); ex John Dannreuther Library.

File on Patterns from the Wayte Raymond Library

340 Adams, Edgar H., et al. FILE FOLDER OF MOUNTED PAGES FROM THE ADAMS-WOODIN BOOK, FROM WAYTE RAYMOND'S LIBRARY, INTEGRATING NOTES BY EDGAR H. ADAMS, WITH ADDITIONAL MATERIAL ON THE NEWCOMER COLLECTION, A LETTER BY LENOX R. LOHR, ETC. Materials loosely assembled as described in the comments. Generally very good. **\$1500**

A unique and most interesting assemblage, including: the relevant pages, and title, from Adams & Woodin's 1913 *United States Pattern, Trial, and Experimental Pieces*, pasted to 8.5 by 11 inch blank sheets, holed for a three-ring binder, featuring ink check marks throughout which, according to John Ford, appear to record specimens in the collection of Waldo Newcomer. There are also extensive ink additions on the blank sheets and sometimes in the text, comprising additions and corrections. A few examples follow of what are certainly notes made by Edgar Adams: "17A. Eagle 1795. Reg. Dies. Small planchet. Copper, only one specimen known"; "struck outside of mint" written after Nos. 27 & 28, which have been lined through; "Both out. Not struck at mint" written after Nos. 29 & 30; following 1848 Quarter Eagle, 1848: "Have classified my spec. under Territorial coins of California"; "193A. Eagle, slightly dif. Die, platinum"; and 827, "struck on five-cent planchet." Present as well are 5 typewritten sheets formatted in typical Adams style, with 16 photographs of coins cut to size and mounted preceding the descriptions, listing thirty-one 1838 & 1839 half dollar pieces, a few with notes such as "Does not exist" or "I have never seen..." Also present are added typescript pages listing Nos. 451-454, 454A, 455-457, & 457A-F, and pages reordering Nos. 480-85, and 508-527. There are also three pages of typescript listing twenty-five 1867 nickels, thirteen of which are accompanied by photographs, and another page listing Nos. 684-698A, with photographs of No. 687. Wayte Raymond's handwritten listing of minor patterns, annotated in pencil, on over a dozen sheets is accompanied by a typewritten September 25, 1946 letter from Lenox R. Lohr, signed, on Museum

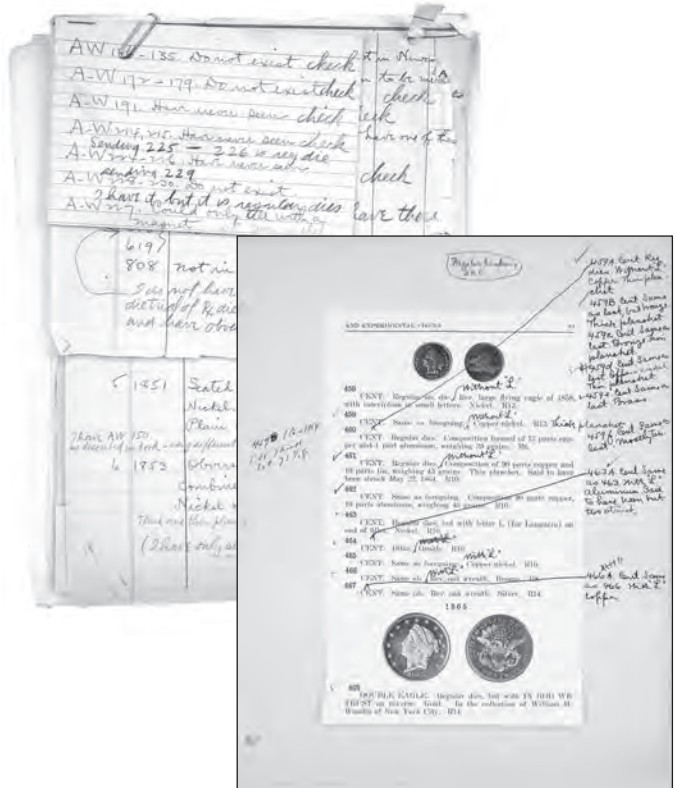

of Science and Industry, Chicago stationery (Lohr is listed as President), to Wayte Raymond, reading in part: "I am returning herewith your check list of pattern nickels with pencil notations as suggested by comparison with my own collection... Some of the very distinctive patterns were apparently omitted from your list. I have listed them on the attached sheet [also present here] ... If you come into possession of any patterns, trials, or die strikes, I wish you would send them on to me for inspection." Ex John J. Ford, Jr. Library (Kolbe Sale 93, lot 125); ex John Dannreuther Library.

Deluxe Edition *Comitia Americana* with Franklin Plate

341 Adams, John W. and Anne E. Bentley. *COMITIA AMERICANA AND RELATED MEDALS: UNDERAPPRECIATED MONUMENTS TO OUR HERITAGE—A LEAF BOOK*. Crestline: George Frederick Kolbe, 2007. 8vo, light brown full morocco; spine with leather spine label, gilt. 351, (1) pages printed by letter-press on fine paper; 57 color plates and an original engraving for J.F. Loubat's *The Medalllic History of the United States*. Housed in original clamshell box. Fine. **\$900**

Perhaps the most luxurious deluxe edition of a numismatic book published in recent years. Limited to 60 copies printed by letterpress by Henry Morris, of Bird & Bull Press. A magnificent production. Citing from the preface: "The regular edition of *Comitia Americana and Related Medals* has been shaped for the scholar and the collector... The special edition at hand is intended to serve a different purpose. Here, the authors' objective is to place the reader in a closer relationship with the historical events that are described. To this end, the text of this edition has been prepared by the same letterpress technology in use in the late eighteenth century. The two centuries that lie between the American Revolution and the present day are neatly bridged by the inclusion of a leaf from a book published in 1878. Joseph Florimond Loubat's *Medal-*

lic History of the United States is the spiritual ancestor of the present volume. Elegantly printed on sumptuous paper, Loubat's magnum opus sets a standard of scholarly excellence that has not been matched and to which, immodestly, we aspire. Between the timeless craftsmanship of Bird & Bull Press and the actual leaf from Loubat, the authors seek to reinforce the message that our early medals were intended to convey. It is a noble message. We hope that this special edition will prove a worthy carrier of important memories that comprise our national heritage." The leaf from Loubat in this copy of the deluxe edition features the 1786 Benjamin Franklin medal (Betts 620).

Hardcover Set of Pittman Collection Sales

342 Akers Numismatics, David. *THE JOHN JAY PITTMAN COLLECTION. SELECTED NUMISMATIC RARITIES. PARTS ONE-THREE*. Baltimore & Rosemont, 1997-1999. Three volumes. 4to, original matching red leatherette, gilt; original pictorial card covers bound in. xvi, 303, (1); xvi, 276; xvi, 503, (1) pages; 5250 lots; including 48 color plates; illustrated throughout, including many coin enlargements. Prices realized lists housed in special pockets on the rear boards. Signed bookplates in each volume, as issued. Fine. [with] Akers Numismatics, David. *THE THAINE B. PRICE COLLECTION*. Baltimore,

May 19, 1998. 4to, original blue leatherette; gilt; original pictorial card covers. xi, (1), 120 pages; 213 lots; illustrated. With prices realized list. Fine. **\$500**

A complete set of the Special Hardcover Editions of the catalogues prepared for the John Jay Pittman collection, one of the truly great U.S. collections of the twentieth century. Infrequently offered. This set is No. 110 of 250 sets issued. The Price collection catalogue was distributed as a free accompaniment for those who subscribed to the Pittman hardcovers, and is also No. 110 of 250. Ex John Dannreuther Library.

Complete Pittman Catalogues

343 Akers Numismatics, David. **THE JOHN JAY PITTMAN COLLECTION. SELECTED NUMISMATIC RARITIES. PARTS ONE-THREE.** Baltimore & Rosemont, 1997-1999. Three volumes. 4to, original matching pictorial card covers. 1132 pages including 48 color plates; 5250 lots; illustrated throughout, including many coin enlargements. Various inserts; second with prices realized list. Fine. **\$150**

A complete set of the catalogues prepared for the John Jay Pittman collection, one of the truly great U.S. collections of the twentieth century. Ex Richard E. Margolis Library.

Reprint of the First Six Volumes of the Numismatist

344 American Numismatic Association. **THE NUMISMATIST AND YEAR BOOK. VOLUME ONE: 1888-1893.** Salina: Olympic Press, 1963 reprint. 8vo, original maroon cloth, gilt. (4); 26; 48; 112; 106; 112; 176 pages; portrait plates; text illustrations. Fine. **\$200**

The now scarce reprint of the first six volumes of *The Numismatist*. Ex Roger Persichilli Library.

Original Andrews on Large Cents

345 Andrews, Frank D. **AN ARRANGEMENT OF UNITED STATES COPPER CENTS, 1816-1857, FOR THE ASSISTANCE OF COLLECTORS.** Second edition. Vineland, 1883. Oblong 12mo, later red cloth, gilt; original printed salmon paper covers bound in. 42 pages. Fine. **\$250**

Ex Matt Rothert, with his label. Frank Dewette Andrews (1847-1937) made the first attempt to comprehensively cover the later dates, and this second edition remained the standard work until superseded in 1944 by Newcomb. James Macallister thought highly of Andrews calling him "a keen student, with a remarkable memory" and he noted that "I am inclined to believe that he saw every Cent he listed." According to Sheldon, Andrews's "remarkably thorough little monograph" was the fruit of research spanning twenty years. In the preface, the author describes his work as "the result of careful observation" and opines "Perhaps it would not be advisable to spend time that could be better employed on a subject of so little practical importance: but as a recreation from tasks more severe; as a means of training the eye to observe minor differences and variations; and of assistance to the mind in times of mental depression, the *Numismatist* will find it of much value." Ex Kolbe Sale 38, lot 40. Ex Roger Persichilli Library.

Priced & Named 1855 Flandin Sale

346 Bangs, Brother & Co. **CATALOGUE OF A VALUABLE COLLECTION OF AMERICAN AND FOREIGN COINS AND MEDALS, IN GOLD, SILVER, COPPER AND BRONZE.** New York, June 6, 1855. 8vo, original printed cream-colored paper covers. 14, (2) pages; 230 + 1 lots (added lot: "a

number of American Genls. and Commanders vc, 10 pieces," written in ink at the end), priced in black with buyers' names throughout. Back cover a trifle discolored. Near fine. **\$250**

Adams 1 for the Bangs series. One of the earliest significant U.S. numismatic auction sales, the Peter Flandin collection was the first entirely numismatic auction to be held in New York City, and is the earliest catalogue included in John W. Adams's *United States Numismatic Literature*. The cataloguer of the sale is unknown and is a matter of some dispute, with Gengerke and Adams having attributed it to Augustus B. Sage in the past, but Q. David Bowers making a good case against this (as Sage would have been too young to have catalogued it) and suggesting Charles I. Bushnell as a possibility. Flandin (whose actual first name was Pierre, according to Pete Smith) was a collector as early as 1822. His collection consisted mostly of ancient and European coins, but did contain some early American coins and Washington material, as well as federal coins including a proof 1850 dollar. Total proceeds for the sale were \$733.52. A scarce catalogue, especially priced and named. Flandin appears to have bought back a number of lots. While household names like Bushnell and Chilton are recorded after a number of lots, none of the dealers who burst upon the scene in the following decade appear to have attended the sale, and most of the other participants (Gsell, Carlisle, Burtis, Borg, Reiley, Creighton, Boardman, et al.) appear to have been of an earlier generation, and are little known today. Attinelli 10. Ex John J. Ford, Jr. Library (Kolbe Sale 93, lot 164); ex John Dannreuther Library.

Early Illustrations of American State Coppers

347 Barber, John Warner. **THE HISTORY AND ANTIQUITIES OF NEW ENGLAND, NEW YORK, AND NEW JERSEY...**

Worcester: Dorr, Howland & Co., 1841. 8vo, original full brown calf; spine intricately decorated and lettered in gilt. viii, (9)-576 pages; engraved frontispiece; engraved hand-colored folding map; numerous woodcut illustrations in the text, including depictions of both sides of a Pine Tree shilling and the copper coins of New Jersey, Massachusetts and Connecticut. Some foxing throughout, as is apparently typical of this title. Very good or better. **\$550**

Important for the early illustrations of Massachusetts silver and the state coppers of New Jersey, Connecticut and Massachusetts: these are quite possibly the earliest depictions of the Connecticut and Massachusetts coppers. Pages 523-527 comprise an account of "Coinage, Bills of Credit, &c.," and include the numismatic illustrations noted. This is the nicest copy we have handled. Howes B124. Sigler 158 (slightly different title).

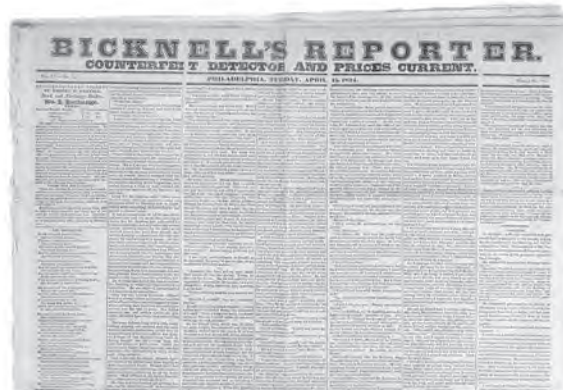

Very Early Bicknell Reporter

348 Bicknell, Robert T. **BICKNELL'S REPORTER. COUNTERFEIT DETECTOR AND PRICES CURRENT.** Philadel-

phia: Published Every Tuesday by Robert T. Bicknell, Stock and Exchange Broker, (April 15, 1834). Volume IV, No. 38. Large tabloid [around 60 by 44.5 cm], 4 pages. Old tape repair; spine fold weak. Good to very good. **\$250**

One of the earliest issues of this interesting publication that we have handled. Very rare: the Ford library, notable for his collection of counterfeit detectors and bank note reporters, had no Bicknell publications. Dillistin pages 125–128: “In 1830, when there were approximately 330 banks operating in this country, Robert T. Bicknell, a lottery broker in Philadelphia, began the publication of a bank note reporter and counterfeit detector. He was the pioneer in this field in Philadelphia and was preceded only by Mahlon Day and S.J. Sylvester in New York.” Bicknell died in 1839, only 33 years of age. The publication was continued for years thereafter, however, by Matthew T. Miller, who continued the publication until 1857. Most interesting is the “Bank Note List” on the last page of each issue, listing by state the various American banks of issue, along with those of Canada. There are columns for “Name,” “Location,” and “Discount in Philadelphia.” The last column includes designations such as fraud, closed and failed. An asterisk by a bank denotes that “there are either counterfeit or altered notes, of various denominations, in circulation throughout the United States.” This issue also contains short interior articles on bank failures and the importation of specie. By their very nature, bank note reporters and counterfeit detectors had a limited shelf life, and very few copies have survived.

A Comprehensive Run of Bolender Sales

349 Bolender, M.H. NUMISMATIC AUCTION SALES. Group of 148 auction catalogues, 1928–1960, being Nos. 45–51, 53–109, 111–137, 140–183, and 185–197. Twelve of them have either printed prices realized lists laid in or are hand-priced. Varying formats, original printed card covers. Generally near fine or better, with a few in lesser condition. **\$350**

A substantial collection, being 148 of Bolender’s 197 sales. The present set comprises most of the collectible catalogues: Sale 40 is the earliest seen with any regularity, and this set begins at No. 45. The lot includes A.L. Doherty’s collection of Washingtonia, P.C. Clark’s superb patterns, Bolender’s own collection, H.A. Sternberg’s collection, A.P. Wylie’s Confederate paper money and a number of others.

Bolender Sale Rarity

350 Bolender, M.H. 184TH MAIL AUCTION SALE. THE LOUIS L. LINCOLN COLLECTION OF U.S. SILVER HALF-DOLLARS. ALSO CHOICE CONSIGNMENT OF EARLY AMERICAN SILVER DOLLARS FROM THE CABINETS OF AN EASTERN GENTLEMAN. PROOF CORONATION SET OF GEORGE VI OF ENGLAND, 1937. \$4.00 GOLD PIECE 1879 PROOF. San Marino, April 8, 1953. Thin 8vo, original printed card covers. 16 pages; 313 lots. Near fine. **\$150**

Adams 184. Bolender’s first sale held in California, to which he retired (more or less) after suffering a serious heart attack on Christmas Day 1951, brought on by shoveling snow for two hours in anticipation of visiting relatives. He survived, but the experience slowed him down. Managing with some help to sell his own collection in Sale 183, over a year passed before this slender but interesting sale was held. He acknowledged in Sale 185 that he had received many inquiries from collectors wondering why they had been dropped from his mailing list—clearly he had cut it drastically with the move out west. This catalogue is usually available only when we offer comprehensive sets of Bolender catalogues. The half dollar collection comprises the first 272 lots, with thirty lots of early dollars following.

ANA Centennial Volumes

351 Bowers, Q. David. THE AMERICAN NUMISMATIC ASSOCIATION CENTENNIAL HISTORY. Wolfeboro, 1991. Two volumes. 4to, original matching maroon leatherette, gilt. xi, (1), 842; (8), 843–1744 pages; illustrations. Fine. [with] Carlson, Carl W.A., and Michael Hodder [editors]. THE AMERICAN NUMISMATIC ASSOCIATION CENTENNIAL ANTHOLOGY. Wolfeboro, 1991. 4to, original maroon leatherette, gilt. (12), 372 pages; text illustrations. Fine. **\$100**

The main work is a remarkable source of useful information, being a history of the association “as taken from the pages of *The Numismatist*,” viewed from the author’s perspective, and is an excellent distillation featuring quite a number of useful appendices and two indices. The anthology issued at the same time is important, and includes Eric P. Newman’s “Heath’s Counterfeit Detectors: An Extraordinarily Successful Comedy of Errors” and Martin Gengerke’s “History of the Fractional Currency Presentation Books,” both of which are listed in Kolbe’s *Reference Library*. Kolbe 397. Ex TAB Library.

Hardcover Bowers Silver Dollar Encyclopedia

352 Bowers, Q. David. SILVER DOLLARS AND TRADE DOLLARS OF THE UNITED STATES: A COMPLETE ENCYCLOPEDIA. VOLUME ONE: SILVER DOLLARS 1794–1873. TRADE DOLLARS 1873–1885. VOLUME TWO: U.S. DOLLARS 1878–DATE. COMMEMORATIVE DOLLARS 1900–DATE. Wolfeboro, 1993. Two volumes. 4to, original matching pictorial boards. xx, (2), 1096, (2); (8), 2005–3067, (1) pages; text illustrations. Spines sunned, else fine. **\$150**

The standard work on the subject. Ex TAB Library.

Treasure from the California Gold Rush

353 Bowers, Q. David. A CALIFORNIA GOLD RUSH HISTORY, FEATURING THE TREASURE FROM THE S.S. CENTRAL AMERICA: A SOURCE BOOK FOR THE GOLD RUSH HISTORIAN AND NUMISMATIST. Newport Beach, 2002. Folio, original black leatherette, gilt. 1055, (1) pages; profusely illustrated, including many full page illustrations. New, still in shrink-wrap. **\$100**

A massive and important work. Ex TAB Library.

Garrett Sales & History in Original Boxes

354 Bowers and Ruddy Galleries. THE GARRETT COLLECTION SALES. PARTS I–IV. 1979–1981. Four illustrated volumes, complete. 4to, original black textured cloth, gilt. Prices realized lists bound in. Fine, housed in original mailing cartons. [with] Bowers, Q. David. THE HISTORY OF UNITED STATES COINAGE AS ILLUSTRATED BY THE GARRETT COLLECTION. Los Angeles: Bowers & Ruddy, 1979. 4to, original black textured cloth, gilt; printed illustration mounted to front cover. xv, (1), 572, (4) pages. Fine, housed in original mailing carton. **\$100**

The Deluxe Limited Hardbound Editions of the series of four catalogues that changed the American numismatic landscape, along with one of the finest single-volume works on U.S. numismatics. Ex Roger Persichilli Library.

Deluxe Edition Adams Large Cents

355 Bowers and Ruddy Galleries. THE CELEBRATED JOHN W. ADAMS COLLECTION OF UNITED STATES LARGE

CENTS OF THE YEAR 1794. Los Angeles, 1982. 4to, original grained cream cloth, gilt; original printed card covers bound in. 134 pages; portrait; enlarged text illustrations; 2 photographic plates of large cents in color. Price list laid in. Fine. **\$150**

Special Limited Library Edition. One of 256 numbered copies, signed by the authors. A superb collection, mostly comprised of coins with remarkable pedigrees extending into the nineteenth century. Ex Roger Persichilli Library.

Taylor Sale with Limited Edition Photographic Plates

356 Bowers and Merena Galleries. **THE FREDERICK B. TAYLOR COLLECTION AND OTHER PROPERTIES.** New York, March 26–28, 1987. 4to, original pictorial card covers. 317, (3) pages; 3915 lots; color portrait; text illustrations; 3 color plates. Prices realized list laid in. Fine. [with] Bowers and Merena Galleries. **LIMITED EDITION PHOTOGRAPHIC PLATES. STATE COPPER COINAGE 1785–1788. TAYLOR COLLECTION.** (Wolfeboro): Bowers and Merena, 1987. Oblong 4to, original purple leatherette, gilt. Photographic title, limitation leaf, and table of contents leaf; 23 fine cloth-hinged photographic plates of coins with guards. Fine. **\$150**

The important auction catalogue, with the volume of photographic plates. Important for Taylor's extensive collection of colonial and early American coins, featuring Vermont, Connecticut, Massachusetts and New Jersey coppers. The sale also featured the notable Warren Baker collection of Canadian Blacksmith Coppers, catalogued by Michael Oppenheim. The plate volume is Number 99 of only 182 examples issued, signed by Q. David Bowers, Michael Hodder and Cathy Dumont. An excellent photographic record of this remarkable collection. Ex Roger Persichilli Library.

Deluxe Hardcover Bass Collection Sales

357 Bowers and Merena Galleries. **THE HARRY W. BASS, JR. COLLECTION. PARTS I–IV.** New York, 1999–2000. Four volumes, complete. 4to, original matching crimson Japanese cloth; inset printed title cards to front covers, as issued; transparent jackets. 376; 477, (3); 232; 232 pages. 2808; 1965; 920; 981 lots [not always inclusive]. Illustrated. Prices realized lists laid in. All four with limitation notice signed by the principals of the sale. Fine. **\$250**

A complete set of the deluxe hardcover editions of the Bass collection sales, one of the most important sales in U.S. numismatic history, particularly for U.S. gold. Ex John Dannreuther Library.

Breen's CCJ Monographs, Signed

358 Breen, Walter H. **MONOGRAPHS PUBLISHED IN THE COIN COLLECTOR'S JOURNAL.** Six stand-alone publications: *Proof Coins Struck by the United States Mint 1817–1921* (CCJ 148–149); *U.S. Patterns of 1792* (CCJ 154); *The United States Minor Coinages 1793–1916* (CCJ 155); *The Secret History of the Gobrecht Coinages 1836–1840* (CCJ 157–158); *Silver Coinages of the Philadelphia Mint 1794–1916* (CCJ 159); and *United States Half Dimes: A Supplement* (CCJ 160). New York: Wayne Raymond, 1953–1958. 8vo, original printed card covers. All inscribed by Walter Breen to Roger Persichilli. Fine. **\$150**

All six of Breen's important monographs on United States coinage published in the final volumes of the *Coin Collector's Journal*. Individual numbers are occasionally encountered signed, but we do not recall the last time we offered a complete set of them. Ex Roger Persichilli Library.

Breen's Complete Course, Signed

359 Breen, Walter. **A COMPLETE COURSE IN NUMISMATICS.** Beverly Hills: American Institute of Professional Numismatics, undated [c. 1969]. 4to, original blue card covers; (1), 70 pages printed on rectos only. Inscribed by author to Roger Persichilli on cover in purple ink. Very good. **\$100**

Mostly dealing with how to grade coins; perhaps Breen's most extensive treatment of the subject. Rarely encountered signed.

Breen's Complete Encyclopedia, Signed

360 Breen, Walter. **WALTER BREEN'S COMPLETE ENCYCLOPEDIA OF U.S. AND COLONIAL COINS.** New York: FCI/Doubleday, 1988. 4to, original black cloth. xiv, 754 pages; illustrated. Inscribed by Breen to Roger Persichilli on title. Fine. **\$100**

Probably the greatest single attempt to discuss all U.S. coinage, including colonial and private coinages, in a single volume. While some have focused on the text's occasional errors and the volume's production problems, it would be impossible to name another reference work that includes so much solid information on U.S. coins. Kolbe 1093. Ex Roger Persichilli Library.



Plated 1891 Boeing & Bridgman Sale

361 Chapman, S.H. and H. **CATALOGUE OF THE SPLENDID COLLECTION OF ANCIENT GREEK AND ROMAN, GERMAN, EUROPEAN AND ORIENTAL COINS FORMED BY THE LATE WILHELM BOEING, TO WHICH IS ADDED A SUPERB SET OF UNITED STATES SILVER DOLLARS, OF A. BRIDGMAN, JR., ESQ.** Philadelphia: Davis & Harvey, November 27–28, 1891. 8vo, later maroon cloth; spine with gilt-printed black spine labels; original gilt-printed paper covers bound in. 64 pages; 1073 lots; 4 fine tinted photographic plates. Fine. **\$500**

Adams 34, rated A– overall: “Superb German. Bolivar 25 pesos. Gem set of \$1, 1843ff are proofs. Confederate seal, 1¢. Ancient gold.” An important sale featuring rare European coins and the notable Bridgman collection of United States silver dollars. The first plate depicts gold ancient Greek and Roman coins, an octagonal 1852 \$50 slug, an 1849 Mormon \$5, and various foreign gold rarities; the second and third plates mainly illustrate rare silver European coins; and the final plate depicts the obverses of twelve of Bridgman's silver dollars. Clain-Stefanelli 12369. Davis 187. Fanning, *Ancient Coins in Early American Auctions*, 10. Ex Roger Persichilli Library.

The Chaloner Sale with Plates

362 Chapman, S.H. & H. CATALOGUE OF THE COLLECTION OF GREEK, ROMAN AND ENGLISH COINS, AND OF WAR MEDALS AND DECORATIONS, THE PROPERTY OF A FORMER OFFICER IN THE ARMY, AND THE COLLECTION OF COINS OF THE UNITED STATES AND CANADA, OF MR. E.J.M. CHALONER, OF ENGLAND. Philadelphia: Davis & Harvey, April 29–30, 1895. 8vo, later maroon cloth; spine with gilt-printed black spine labels; original gilt-printed paper covers bound in. iv, 51, (1) pages; 883 lots; 5 fine tinted collotype plates with tissue guards. Fine. **\$400**

Adams 45. A well-preserved example of this important sale of English coins and medals, choice ancient coins and American colonials, featuring an extensive collection of Canadian tokens. Plate I depicts ancient and English gold coins; Plate II illustrates ancient and English silver coins; Plate III depicts orders and decorations; Plate IV illustrates American colonial coins, a 1796 quarter dollar, and Canadian tokens and a medal; and Plate V depicts Canadian bank tokens, mostly Bank of Montreal side-view tokens. Davis 189. Fanning, *Ancient Coins in Early American Auctions*, 12. Ex Roger Persichilli Library.

Plated Wetmore Sale, ex Ford

363 Chapman, S.H. and H. THE COLLECTION OF COINS OF THE UNITED STATES FORMED BY MAJOR WILLIAM BOERUM WETMORE. AN ORIGINAL 1804 U.S. DOLLAR. Philadelphia: Davis & Harvey, June 27–28, 1906. 8vo, original gilt-printed white paper covers. (2), ii, 75, (1) pages; 1290 lots; 5 fine photographic plates. Hand-priced in red ink. Very good or better. **\$450**

Adams 82. Adams A: "Proof 1831, 1846 \$2.50. 1863–1881 gold proof sets. 1804 \$1 with analysis. 1827 25¢. Fine cents: MS 1808, 1811, Proof 1823, 1829." A notable sale of United States large cents, rare gold, gold proofs and silver coins, with a long description of the 1804 dollar. The first two plates depict American gold coins; the third plate illustrates silver dollars, an 1802 half dime, and an 1827 quarter; and the final two plates depict choice cents. 12435. Davis 196. Ex John J. Ford, Jr. Library (Kolbe Sale 93, lot 283). Ex John Dannreuther Library.



The George H. Earle Catalogue, with Plates

364 Chapman, Henry. CATALOGUE OF THE MAGNIFICENT COLLECTION OF ANCIENT GREEK AND ROMAN, EUROPEAN, ORIENTAL, EARLY AMERICAN AND UNITED STATES COINS OF GEORGE H. EARLE, JR., ESQ.,

PHILADELPHIA. Philadelphia: Davis & Harvey, June 25–29, 1912. 4to, disbound. v, (3), 225, (1), (12) pages; 3875 lots; 39 very fine photographic plates. Original printed prices realized list included. Catalogue removed from binding; still sewn but lacking covers. Good, but able to be restored. **\$600**

Adams 19, rated A+ overall: "One of the great collections: balanced strength in ancients, European and U.S. rarities and high condition." The Earle sale realized \$55,821.63, a record at the time. While not as extensive as the Jenks collection, coin for coin it is probably superior. The ancient, European and American sections are particularly remarkable, for rarity and condition alike. In the preface, Chapman termed it "the finest collection ever offered in this country." Plates I–V depict classic ancient Greek coins of fine style; plates VI–IX illustrate choice Roman and Byzantine portrait coins; plates X–XVIII depict European rarities; plate XIX illustrates orders and decorations; plates XX–XXIV depict an astounding array of American colonial, state coins and Washingtonia; plate XXV illustrates a remarkable panoply of rare American patterns; plates XXVI–XXVIII depict superb United States gold coins; plates XXIX–XXXIII illustrate the superb series of American silver coins; plates XXXIV–XXXVII depict outstanding large cents; plate XXXVIII illustrates choice half cents; and, finally, plate XXXIX depicts slugs and other pioneer gold rarities. Davis 203. Grierson 275. Spring 99. Ex John J. Ford, Jr. Library (Kolbe Sale 93, lot 315). Fanning, *Ancient Coins in Early American Auctions*, 16, rated the single most important American catalogue of ancient coins before 1940. Ex John Dannreuther Library.

John Story Jenks Sale, with Reprint Plates

365 Chapman, Henry. CATALOGUE OF THE JOHN STORY JENKS COLLECTION OF COINS. ANCIENT GREEK, ROMAN AND THE ENTIRE WORLD. EARLY AMERICAN COLONIAL AND STATE ISSUES AND UNITED STATES PATTERNS AND THE REGULAR SERIES. Philadelphia: Davis & Harvey, December 7–17, 1921. 4to, original white cloth, gilt. xii, 653, (3) pages; 7302 lots; set of 42 reprint plates bound in. Mostly hand-priced in pencil with many buyer names recorded. Rebacked; cloth moderately discolored; one signature loose; very good or so. **\$200**

Adams 40, rated A+ overall: "Henry Chapman's magnum opus. Superb coins of the world plus U.S. all series, all expertly described." The most famous of the Chapman sales and one of the most renowned American coin auction ever held. For years the Jenks catalogue served as the best American single reference guide to the entire range of numismatics. Clain-Stefanelli 7997*. Davis 210. Grierson 276. Ex John Dannreuther Library.

Clapp & Newcomb on 1795–1797 & 1800 Large Cents

367 Clapp, George H., and Howard R. Newcomb. THE UNITED STATES CENTS OF THE YEARS 1795, 1796, 1797 AND 1800. New York: American Numismatic Society, 1947. 4to, original black and blue cloth, gilt; original glassine jacket. vi, 74 pages; title printed in red and black; 4 fine photographic plates. Glassine jacket worn at extremities. Fine. **\$100**

The last of the classic pre-Sheldon works on large cents. Clain-Stefanelli 12274. Ex Roger Persichilli Library.

All lots illustrated in full color at

bid.numislit.com

The Very Rare F.R. Alvord Sale with Plates

366 Chapman, S.H. THE SUPERLATIVE COLLECTION OF UNITED STATES HALF CENTS, COMPLETE IN ALL DATES AND VARIETIES OF THE LATE F.R. ALVORD, ESQ. YORK, PENNA. Philadelphia: Davis & Harvey, June 9, 1924. 8vo, bound by Alan Grace in ivory half calf, original gilt-printed white paper covers mounted to front and back; spine ruled and lettered in gilt, including Armand Champa's name at base. 20, (2) pages; 255 lots; 5 very fine photographic plates of half cents, mounted on linen and with tissue interleaves. Original printed prices realized list tipped in. Fine or nearly so, and housed in an accompanying slipcase. **\$1200**

Adams 28. A well-preserved example of this rare catalogue, in its original state. Only two dozen copies were issued with plates and considerably fewer copies appear to have survived the intervening years. Our census is as follows (in no particular order):

1. The first Harry W. Bass, Jr. copy, in original paper covers with prices realized list. Sold in Kolbe Sale 75 (lot 92) at \$2500.
2. The second Harry W. Bass, Jr. copy, now in maroon cloth, priced in black ink, also with prices realized list. Most recently sold in Kolbe & Fanning's 2018 New York Book Auction (lot 347), ex William A. Burd Library, for \$1500; ex Kolbe & Fanning Sale 137 (lot 55) at \$1700; ex Harry W. Bass, Jr. Library (Kolbe Sale 78, lot 151) at \$2600, after which sale it was rebound; ex George Fuld Library (Katen Sale 37, part of lot 907).
3. The John W. Adams copy, in original paper covers with prices realized list tipped in. Most recently sold in Kolbe & Fanning's Sale 150 (lot 91) at \$1500.
4. The Colonel E.H.R. Green copy, in blue half morocco priced in blue pencil. Last sold in Kolbe Sale 107 (lot 46) at \$4250; ex John J. Ford, Jr. Library (Kolbe Sale 93, lot 353 at \$5500); ex Colonel E.H.R. Green Library.
5. The Armand Champa copy, bound in full calf with prices realized list. Last sold in Part I of the Bowers/Davis sale of the Champa Library (lot 159) at \$1700 hammer. It is possible that this is either copy 7 or 8 below, rebound for Champa by Alan Grace.
6. The present lot. A second Armand Champa copy, bound in half calf with card covers trimmed and mounted to sides, prices realized list tipped in. It is also possible that this is either copy 7 or 8 below, rebound for Champa by Alan Grace.
7. The Richard Picker copy, in crimson cloth with prices realized list. Sold in Kolbe Sale 18 (lot 261) at \$1800.
8. The Theodore Louis Craige copy, in the original paper covers with the prices realized list tipped in. Sold in Kolbe Sale 14 (lot 897) at \$2100.
9. The Dan Hamelberg copy, in the original paper covers, priced in ink. Acquired privately from Jack Collins; ex

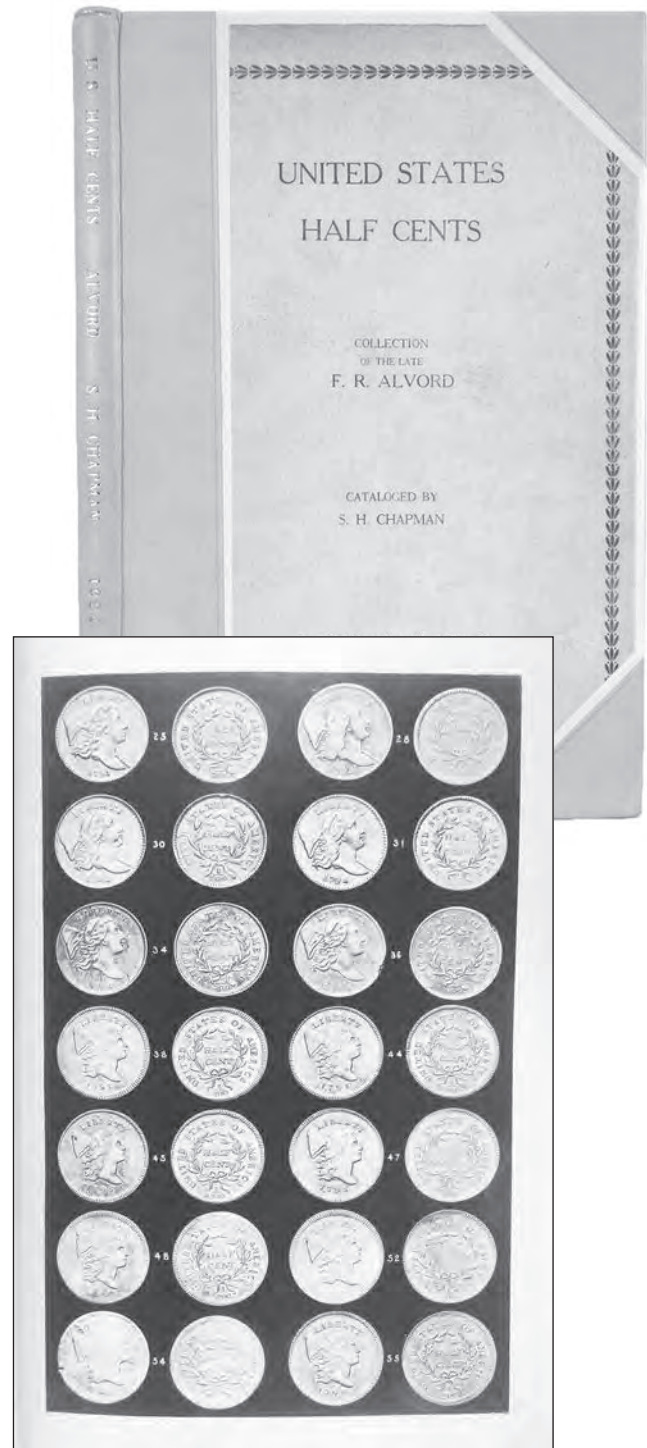

Kolbe Sale 19 (lot 70) at \$1300.

10. The ANS Library copy.

Adams A: "Arguably the best collection ever of half cents: complete original proofs." Little appears to be known about Frederick Reed Alvord, but the superb photographic illustrations of his half cents present here testify elegantly to the magnificence of his collection. Davis 231. Ex Armand Champa Library; ex Roger Persichilli Library.

Original 1875 Crosby, with 1873 Intro, 1874 Circular, &c.

370 Crosby, Sylvester S. *THE EARLY COINS OF AMERICA; AND THE LAWS GOVERNING THEIR ISSUE. COMPRISING ALSO DESCRIPTIONS OF THE WASHINGTON PIECES, THE ANGLO-AMERICAN TOKENS, MANY PIECES OF UNKNOWN ORIGIN, OF THE SEVENTEENTH AND EIGHTEENTH CENTURIES, AND THE FIRST PATTERNS OF THE UNITED STATES MINT.* Boston: Published by the Author, 1875. 4to, later black quarter morocco with green cloth sides; spine with five raised bands, ruled, lettered and decorated in gilt; top page edges gilt; decorative endpapers. (2), v, (5), (11)–381, (1) pages; 110 wood engravings in the text; 2 folding heliotype manuscript facsimiles; 10 fine heliotype plates of coins and tokens with original tissue guards. Bound at the end are: the original 1873-dated title page and introduction; Crosby's October 1874 circular to subscribers stating that the volume had to be extended to an eleventh part; original paper covers for Parts I, II, and XI–XII, with an extra rear cover and a circular for the 1873 *Banker's Almanac* also included. Inscribed and signed by Isaac F. Wood, presenting the volume to the Union League Club in 1877; Wood's donation recorded in ink on the title. Professionally rebacked. Fore-edge untrimmed. Very good or better. **\$1500**

An interesting copy of what is arguably the best and certainly the most enduring work on American numismatics ever written. Sylvester Sage Crosby began gathering information for his magnum opus in the late 1860s. Nominally the head of a committee of six appointed by the New England Numismatic and Archæological Society to publish a work on early American coinage, he soon found himself alone in that pursuit. Not only was the research and composition of the work done almost entirely by Crosby, ultimately he also had to publish it. "It is truly the keystone to any library of American coinage." — Eric P. Newman. This copy includes some of the materials that were only sent to original subscribers to the text, which was printed in installments and sent to subscribers in eleven separate installments; the un-

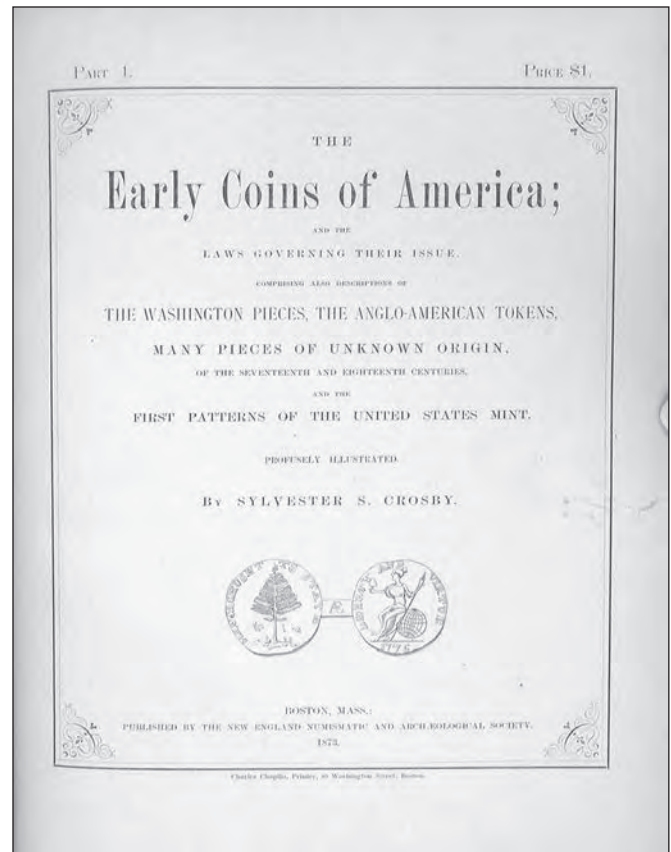

trimmed fore-edges also indicate that this copy was bound from the separate parts, and was not issued by Crosby in book form (as most were). State with overprinted coin numbers on Plates IV and V. Coin 15a on Plate VII hand-numbered in pencil, apparently as always. Without the handwritten correction, sometimes seen, to Miss Eliza Susan Quincy's name in the subscribers' list on page 381. Voted No. 2 on the Numismatic Bibliomania Society's "One Hundred Greatest Items of United States Numismatic Literature." Attinelli 105. Claim-Stefanelli 12115*. Davis 291. Grierson 218. Sigler 603. Ex Roger Persichilli Library.

Album of Reproduced Crosby Photos & Memorabilia

371 Crosby, Sylvester S. *ALBUM COMPILED BY ROBERT WESTER FOR ROGER PERSICHILLI REPRODUCING PHOTOS AND OTHER MEMORABILIA RELATING TO SYLVESTER S. CROSBY AND FAMILY.* 28 by 25.5 cm, cardstock album, apparently assembled in 1988. 10 leaves, on both sides of which is either writing, pasted reproductions of photographs, or both. Includes ten reproductions of early photos of Crosby and his family, along with modern photos of Crosby-related medals, several letters to Persichilli or Wester, Wester's reproduction of the well-known photograph depicting Dr. Montroville Dickeson with a Native American, and much handwritten commentary. Fine. **\$300**

A truly charming production that illustrates numismatic friendship at its best. Many of the original photographs, silhouettes, etc., from the Crosby family that were in Bob Wester's collection ended up in



Jeff Hosford's Crosby collection, which we sold in our 2011 New York Book Auction (the photo of the home of Crosby's father, destroyed by fire in 1865, hangs on our wall as we write this). Wester and Persichilli met through Armand Champa and quickly became friends. A special item. Ex Roger Persichilli Library.

Cogan's First Sale

368 Cogan, Edward. **PRICED CATALOGUE OF THE PRIVATE COLLECTION OF UNITED STATES CENTS, THE PROPERTY OF EDWARD COGAN, SOLD AT HIS STORE BY PRIVATE BIDDINGS, THE 1ST NOVEMBER 1858.** Philadelphia, 1863. 8vo, original printed paper covers. (4) pages; (77) lots; printed prices realized. Near fine. **\$100**

Adams 1. The important 1863 printing of Edward Cogan's first sale. As Adams explains (page 18), "The first four sales in the Cogan series are not catalogs in the standard sense; rather they are later... reprints from single manuscripts available in Cogan's store. Local patrons used this list to scout for coins of their choice; bids in these cases were submitted in sealed envelopes which were all then opened on the appointed day." Attinelli 13. Ex Roger Persichilli Library.

The Colonial Newsletter

369 Colonial Newsletter Foundation. **THE COLONIAL NEWSLETTER.** Volumes 1–38, Serial Nos. 1–109 (Huntsville etc., 1960–1998). Complete for the period covered. 8.5 by 11 pages, generally 3-hole punched for inclusion in a binder. 1894 pages; illustrated. The initial nineteen issues are the 1975–1976 printings. Generally near fine. **\$150**

An indispensable source of information for anyone seriously interested in early American numismatics, also featuring much of interest on its literature, particularly in the earlier issues. Ex Richard E. Margolis Library.

Contemporary Works on Colonial Currency

372 Davis, Andrew McFarland. **COLONIAL CURRENCY REPRINTS 1682–1751.** New York: Burt Franklin reprint. Four volumes, complete. Small 4to, original matching blue cloth, gilt. xx, 471, (1); xii, 470; xix, (1), 496; xvi, 503, (1) pages; title facsimiles. Fine. **\$120**

A mine of information on the numismatic, financial and economic aspects of American colonial currency, comprised of virtually all the contemporary tracts on the topic.

First Edition Dickeson

373 Dickeson, Montroville Wilson. **THE AMERICAN NUMISMATICAL MANUAL OF THE CURRENCY OR MONEY OF THE ABORIGINES, AND COLONIAL, STATE, AND UNITED STATES COINS. WITH HISTORICAL AND DESCRIPTIVE NOTICES OF EACH COIN OR SERIES.** Philadelphia, 1859. First edition. 4to, original blindstamped brown cloth; handsome impression in gilt of an 1849 double eagle on the upper cover, in blind on the rear cover. x, (11)–256 pages; handsome lithographic portrait of the author printed in two colors; frontispiece of the Libertas Americana medal; text illustrations; 19 attractive lithographic plates of coins and currency printed in colors and metallic tints. Binding worn at corners and at head of spine, but sound. Very good or better. **\$200**

An above-average copy of the first work covering the entire range of American numismatics, remarkably free from the spotting often seen. Usually encountered in well-worn condition, especially at the spine, due to the delicate cloth that has become somewhat brittle with age. Dickeson's book is a landmark of American numismatic history. By nature a popularizer and showman, he toured the country for several years in the early 1850s lecturing on North American archeology and excavating Indian mounds. His *Numismatological Manual* (the *al* was dropped after the first edition) was also clearly intended to reach a mass market. Hand-

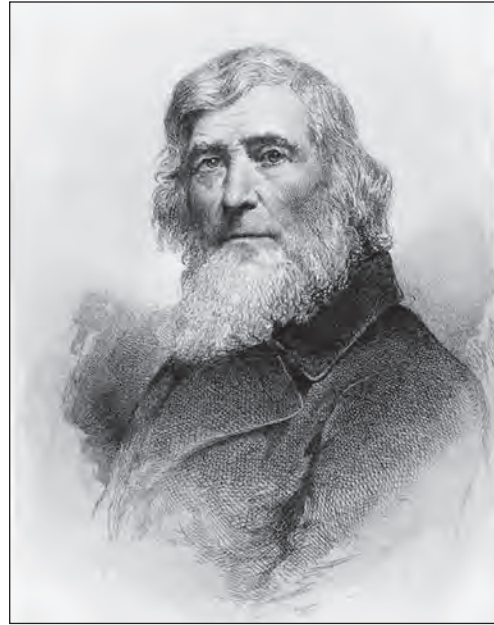

Large-Paper Study of Durand's Engravings

375 Durand, John. **THE LIFE AND TIMES OF A.B. DURAND.** New York: C. Scribner's Sons, 1894. 4to [29.5 by 23.5 cm], contemporary green three-quarter morocco with marbled sides; spine with five raised bands, dated and lettered in gilt; marbled endpapers; top page edges gilt; other page edges untrimmed. Magnificent engraved frontispiece portrait of A.B. Durand by Alfred Jones, with printed tissue guard; ix, (3), 232 pages; engraved dedication portrait by John Durand with tissue guard; 14 additional engraved illustrations with printed tissue guards throughout, including two of bank note vignettes as well as various portraits, landscapes, etc.; limitation slip and errata slip tipped in. Binding rubbed at extremities, with moderate wear; professionally rebacked, with the original spine laid on. Contents near fine. **\$600**

One of only 100 copies printed on large paper, though so many have been disassembled over the years for the plates that intact copies are infrequently encountered. Asher B. Durand was among the finest American engravers of the 19th century, and the plates in this volume, some of them reproduced through the "Goupil Gravure" process of copper-plate etching for photomechanical reproduction, testify to the skill of the artist: his portrait of John Trumbull is of the highest quality, and the later landscapes from the Adirondacks (that made him the nation's foremost proponent of the Hudson River Style) are exceptional. Even the finest engravers often had to turn their skills to more practical matters, however, and Durand is well-known in numismatic circles today for his work in bank note engraving. Two of the plates present in this volume depict three bank note vignettes apiece. Durand is also famous in philately for having engraved the iconic portrait of Benjamin Franklin used on the 1847 5¢ issue (Scott 1). The breathtaking illustrations produced for this important biography of this American artist (written by his son) have made it a celebrated volume in a number of areas of collecting. We sold a copy of the regular edition in a recent sale for \$660 including the premium; this may be the first time we have offered a large-paper copy. The binding is signed (with a diminutive ink stamp) as the work of R.W. Smith.

some in format and visual presentation, it was distributed by a major publisher of the day and written in an authoritative manner. Dickeson even envisaged, "if it should be approved, to prepare an edition for the use of schools." Until the appearance of Breen's magnum opus in 1988, it remained the only comprehensive work on American numismatics ever published. Ex Dan Freidus Library.

First Edition Doughty

374 Doughty, Francis Worcester. **THE CENTS OF THE UNITED STATES: A NUMISMATIC STUDY. EXTENSIVELY ILLUSTRATED FROM SELECTED SPECIMENS.** New York: Scott, 1890. 8vo, original russet cloth, lettered and decorated in gilt. (6), 115, (1) pages; text figures; 2 tables (1 folding); 4 lithographic plates of coins. Near fine. **\$100**

Dr. Sheldon notes that Doughty's work was based on research conducted by David Proskey a decade earlier and published in a series of articles in the *Coin Collector's Journal*. "Proskey was the first to try to bring descriptive order to the study of early cents as a whole." For unknown reasons, Proskey appears to have passed the work and his unfinished notes on to Doughty who republished the work in 1890 under his own name. Sheldon further observes that "The Proskey designations thus became Doughty designations, although it has been said that Doughty scarcely knew one date from another." The first edition is encountered in a variety of bindings. This copy includes John M. Oliver's 1893-dated ownership inscription, and includes two pages of typewritten notes on 1799 cents. Ex Roger Persichilli Library.

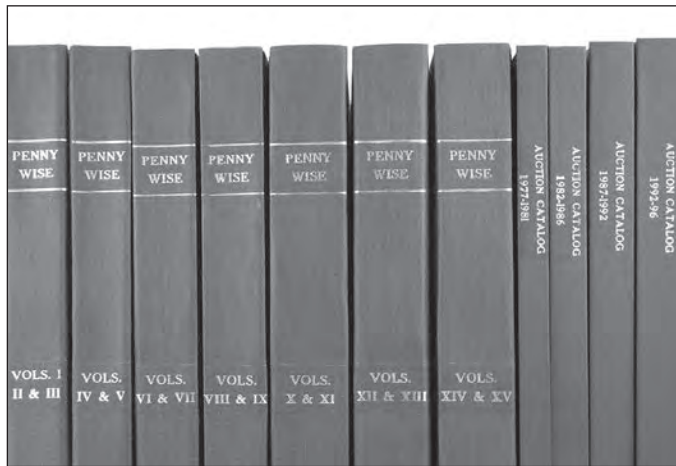

Bound Set of Penny-Wise & EAC Auction Catalogues

376 Early American Coppers. **PENNY-WISE.** Volumes I–XXXIX (1967–2005); consecutive issues 1–231, complete as bound in thirty-two volumes, including the Index for Volumes I–XX. All original copies. 4to, later blue and gray cloth; early volumes with spines lettered in silver, while later volumes feature black spine labels lettered in gilt. Includes many, perhaps all, early inserts. Early issues were folded for mailing and have occasional stains and markings; later issues mostly fine. Two volumes are misnumbered on the spine; included are a number of gilt-lettered black labels stamped with the appropriate lettering to standardize the earlier spine treatments, correct errors, and provide for future volumes if the next owner wishes to continue the set. Volumes as a whole are fine. [with] Early American Coppers. **AUCTION CATALOGUES.** Twenty-four

consecutive auction catalogues from the EAC conventions for 1977–2000, bound in five volumes. 4to, russet cloth with marbled sides; spines lettered in gilt [final volume blank]; original printed paper or card covers bound in. Fine. [with] Early American Coppers. **LATER UNBOUND ISSUES OF PENNY-WISE AND ANNUAL AUCTION CATALOGUES.** Includes 49 issues of *Penny-Wise*, comprising all of the 2006, 2007 and 2009–2012 volumes and assorted issues through 2018, and annual auctions for 1975 and 1976 (issued by Pine Tree Auction Company), as well as 2001–2013 and 2017–2018. Also present are CDs with the digital version of EAC publications through 2011, the *EAC Guide to Early American Coppers* and other mailings. **\$1500**

An attractively bound set of this indispensable source of information on United States large cents and half cents. Certainly the most lively, and perhaps the most important, specialized American numismatic periodical ever issued. The early volumes are rarely seen. The first 12 numbers of this set originally belonged to John W. Young (EAC #37); starting with number 13, they bear the mailing label of Ray D. Munde (EAC #141). They later belonged to William Wilt, from whom they were purchased by Roger Persichilli. The auction catalogues are another important resource for early copper enthusiasts. Stand-alone catalogues have been issued by the club itself for each year since 1977, compiled by various cataloguers. After 2000, the sales were spiral-bound, which makes binding more difficult. A great set for the dedicated EAC member. Ex Roger Persichilli Library.

Signed John J. Ford Publications

378 Ford, John J. **ISSUES OF THE COIN COLLECTOR'S JOURNAL INCLUDING ARTICLES BY JOHN J. FORD, JR.** Four issues: Whole Numbers 134 ("Numismatica Americana: The Confederate Cent"), 135 ("Numismatica Americana: The Bushnell Sale"), 136 ("Numismatica Americana: The Copper Company of Upper Canada"), and 138 ("Numismatica Americana: The Early Coins of America—S.S. Crosby, 1875"). New York: Wayte Raymond, 1951. 8vo, original printed paper covers. All inscribed by John J. Ford, Jr. to Roger Persichilli. Fine. [with] Van Winkle, Mark. **INTERVIEW WITH JOHN J. FORD, JR.** Published in *Legacy for the Contemporary Numismatist*, Volume III, Numbers 1 and 2. Dallas, 1990. 4to, original pictorial paper covers. Both issues of the periodical containing the complete interview. Both issues inscribed to Roger Persichilli by John J. Ford, Jr. in blue ink. Fine. **\$150**

Four notable articles by John J. Ford, Jr. written for Wayte Raymond's *Coin Collector's Journal*, all of them signed by the author, along with both issues of *Legacy* including Mark Van Winkle's fascinating interview with Ford, also signed.

Copy #9 of Frossard on U.S. Copper Coins

379 Frossard, Ed. **MONOGRAPH OF UNITED STATES CENTS AND HALF CENTS ISSUED BETWEEN THE YEARS 1793 AND 1857: TO WHICH IS ADDED A TABLE OF THE PRINCIPAL COINS, TOKENS, JETONS, MEDALETTS, PATTERNS OF COINAGE AND WASHINGTON PIECES, GENERALLY CLASSIFIED UNDER THE HEAD OF COLONIAL COINS. A CONTRIBUTION TO THE NUMISMATIC HISTORY OF THE UNITED STATES.** Irvington: Published by the Author, 1879. Crown 4to, contemporary brown half morocco, gilt, with marbled sides; spine with five raised bands, ruled, let-

The Fuld-Bass Set of Tom Elder Catalogues

Five with Plates, Including Mougey, Gschwend and the Rare 1907 Chase Sale

Including Also His Extremely Rare First Mail-Bid Sale

377 Elder, Thomas L. NUMISMATIC AUCTION CATALOGUES. New York, 1903–1940. Two hundred sixty-one different catalogues and three duplicates, bound in twenty volumes numbered 1–20, plus a large-paper copy of the 1929 S.H. Chapman sale in the original card covers. The following Elder auction sale catalogues are present, listed by Adams numbers: A, 1–24, 26, 28, 30, 33–37, 39–69, 71, 73–82, 84, 86–88, 92, 96, 97, 99–106, 108, 110–112, 114, 118–120, 122–131, 133–138, 140–157, 159, 162–165, 167–169, 171 and 173–292. Nineteen volumes octavo, one volume quarto, later matching brown cloth, gilt; nearly all original printed card covers bound in. A number of catalogues are hand-priced or include printed prices realized lists. The following catalogues with original plates are included:

J.B. Chase (December 19, 1907), 3 fine photographic plates.

Peter Gschwend (June 15–16, 1908), 16 of 17 fine photographic plates.

James B. Wilson (October 5–7, 1907), 28 fine photographic plates.

Peter Mougey (September 1–3, 1910), 42 fine photographic plates.

Sixty-Sixth Sale (September 27–28, 1912), 2 halftone plates.

Minor faults in a few catalogues. Generally near fine. **\$10,000** An extensive run of Elder sales, nearly ninety percent complete, as collected and bound by Melvin and George Fuld, later in the library of Harry W. Bass, Jr. Many of the catalogues were originally in the library of D.W. Valentine, and feature his name and address written on the front cover or title. A number are annotated by Valentine, sometimes including prices and names. Includes five plated sales, including the exceptionally rare 1907 Chase sale. The copy in our 2018 John W. Adams Library sale brought an incredible \$16,000 hammer. It is the only other copy we are aware of to have been offered at auction since the 1970s, not counting the incomplete copy in the Champa Library. The copy here present includes fine, clean plates, and the catalogue itself retains its card covers and is hand-priced. The first plate depicts war medals, mostly British; the second illustrates rare United States gold and large silver coins, patterns, two Oak Tree shillings and a few miscellaneous pieces; the third plate depicts large cents, United States dimes and half dimes, a few United States gold coins, an 1870 pattern dollar, three ancient Greek Alexander III silver tetradrachms from a hoard and a Japanese 5 momme piece from the Meiwa era. The other plated sales are better known, with the Gschwend and Mougey sales being especially noteworthy.

Unplated rarities are perhaps best represented by the first sale here present: Adams A, a March 5, 1903 mail-bid sale held in “Pittsburg” (the spelling was changed in 1911), where he was living before his move to New York. This is a very rare catalogue, and the copy in the Adams Library sale (lot 123) realized \$6500 hammer on what turned out to be an exceptionally low \$500 estimate. Sale 97, another unplated rarity of the series, is also present.

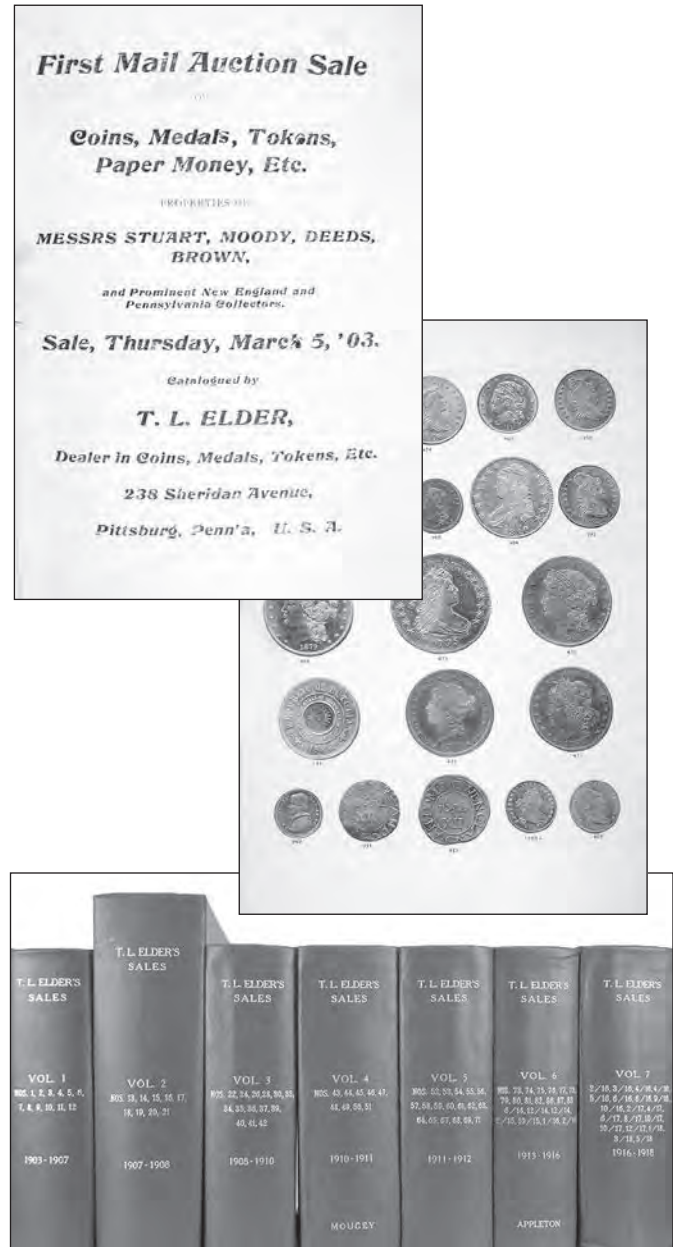

Among the over four linear feet of Thomas Elder catalogues present here is the entire numismatic world, waiting to be unlocked by a persistent and hardy researcher. Elder sold everything, and rarities in nearly all U.S., ancient and foreign series are present in abundance. Nearly every important Elder sale is present in this set and the more important the sale, the more likely it is to be priced. The addition of the five plated sales, particularly the Chase catalogue, adds spice to the mix and the estimate seems modest by any objective standard. Ex Melvin & George Fuld Library (November 27–28, 1971 Katen Sale, lot 977A); ex Harry W. Bass, Jr. Library (Kolbe Sale 77, lot 266); ex John Dannreuther Library.

tered and decorated in gilt; top page edges gilt. 58, (2) pages; 9 heliotype plates with tissue guards [8 plates with numbers and ligatures added in ink]. Spine worn, but binding sound; very good or better. **\$250**

Number 9 of 300 printed. A classic work, the first book-length treatise on the entire series of large cents and half cents. Frossard took the opportunity presented by his January 3, 1879 sale of the George Merritt collection to compile this work, illustrating it with coins from Merritt's collection as well as from that of Lorin G. Parmelee. The book is a good overview of both series and one of the earliest to deal with die varieties for dates past 1794. Of considerable historical importance. Davis 400. Ex Roger Persichilli Library.

Inscribed Frossard & Hays on 1794 Cents

380 Frossard, Ed., and W.W. Hays. **VARIETIES OF UNITED STATES CENTS OF THE YEAR 1794. DESCRIBED AND ILLUSTRATED.** New York: Privately Printed, 1893. Thin 4to, original red cloth, decorated in black and gilt. 18 pages; 2 tinted autotype plates. Inscribed by Frossard to the American Numismatic Association and signed by him in the year of publication. Front hinge cracked; ANA bookplate. Binding unusually clean and bright. Near fine. **\$200**

A pleasing copy of a book that is rarely encountered signed by the author. Written by Frossard and based on Hays's collection. Fifty-six varieties were described, given a new numbering system and, most importantly, for the first time the coins were depicted. In the preface, Frossard notes that "It is but just to my collaborator, Mr. Hays, the man through whose patience and perseverance a complete set of the 1794 Cents was collected, that the varieties in this new classification should bear his name. For this reason, it is desired that when referring to this work the varieties should be announced and known as Hays. No. 1, 2, 3, etc." The book itself is a handsome production, decorative yet finely illustrated. Depicting every variety, it set a high standard for subsequent specialized cent monographs. First binding variant (crimson cloth, one inch decorative bands at top and bottom, without inner filigree to cover device). Until Sheldon's *Early American Cents*, the primary work on the subject. Only 250 copies printed, all of them poorly bound, with cracked hinges and other problems being the rule rather than the exception. I discussed this publication in my column in the January–March 2013 issue of *The Asylum*. Ex Robbins Auctions (New York), September 28, 1979; ex Roger Persichilli Library.

Best 19th-century House Organ

381 Frossard, Ed. [editor]. **NUMISMA.** Minneapolis: Ramm Communications, 1983 reprint. Small 4to, original spiral-bound printed card covers. 500 pages; occasional illustrations. Fine. **\$150**

Copy No. 12 of 100 copies printed and bound in 1983 (the first printing). John W. Adams page 68: "Frossard opened his own business in 1877 and initiated his own periodical, *Numisma*. This latter, undoubtedly the most lively publication of its kind, provides us with an intimate glimpse into the hobby as it and its personalities then existed." A decent reprint of this rare publication, originally issued from 1877 to 1891 by one of America's most colorful and outspoken early coin dealers.

Hardcover Gilbert & Elder on 1796 Cents

382 Gilbert, E., and Thomas L. Elder. **THE VARIETIES OF THE UNITED STATES CENTS OF 1796.** New York, 1909. 4to, original brown cloth, gilt. (16) pages (last leaf blank); 2 fine photographic plates of cents. 1935-dated notation, partly effaced, on

flyleaf. Front cover with some spotting; front hinge cracked. Very good or better. **\$100**

A decent copy of the Special Hardbound Edition. One of only 300 copies printed, most of which were bound in card covers. In a letter sold in our June 1990 Adams sale, George Clapp wrote: "Rud Kohler wrote me that Gilbert once told him that he had loaned his manuscript of 1796 to Elder who wished to look it over, and the first thing he knew, Elder had published it without consulting him." Sheldon confirms this and notes that "Gilbert had the material for a first-rate monograph. It was either not ready or not intended for publication and was badly edited." Ex Roger Persichilli Library.

Hardcover Dan Holmes Sales

383 Goldberg, Ira and Larry, with McCawley-Grellman. **THE DAN HOLMES COLLECTION: PART I. THE EARLY DATES.** Beverly Hills, September 6, 2009. 394, (2) pages; 572 lots. [with] **PART II. THE MIDDLE DATES.** Beverly Hills, May 30, 2010. 320 pages; 563 lots. [with] **PART IV. THE LATE DATES.** Beverly Hills, January 30, 2011. 375, (1) pages; 689 lots. Three illustrated catalogues (of four). 4to, original matching red leatherette lettered in silver; jackets. Parts I and IV still in shrink-wrap; fine. **\$150**

Special hardcover editions. The Holmes collection featured the only complete collection of early dates (including all NCs not in institutions) ever formed. While Part III is not here present, it consisted only of his large cent errors, combined with another collection: the three main sales are present. Ex John Dannreuther Library.

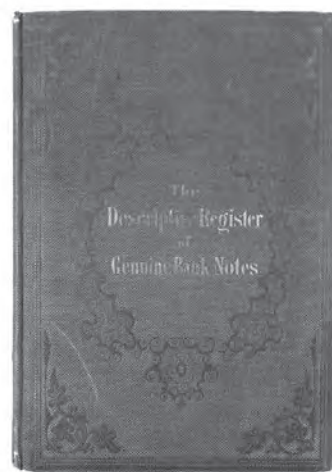

Rare 1862 Gwynne & Day Bank Note Register

384 Gwynne and Day, Bankers. **THE DESCRIPTIVE REGISTER OF GENUINE BANK NOTES, FOR THE DETECTION OF SPURIOUS AND ALTERED BILLS, CONTAINING ACCURATE, ELABORATE AND PLAIN DESCRIPTIONS OF THE NOTES ISSUED BY EVERY BANK IN THE UNITED STATES AND CANADA, CONVENIENTLY ARRANGED FOR REFERENCE...** New York, 1862. 4to, original intricately blindstamped brown cloth, gilt. 162 pages, with the main text ending at 144 and followed by a Supplement comprising pages 145–162. Spine a bit frayed; still very good or better. **\$450**

A very rare edition, though not the last: Dillistin records editions up through 1866 in his 1949 *Bank Note Reporters and Counterfeit Detectors 1826–1866* (page 149). Copies of this edition were in the Champa and

Newman Libraries, but it is worth noting that Ford's holdings did not include this edition. Ex Washington County Bank, according to a penciled note on the front flyleaf; ex Julius Guttag Library, with his ink stamp.

First Edition Heath Counterfeit Detector

385 Heath, Laban. **HEATH'S INFALLIBLE COUNTERFEIT DETECTOR AT SIGHT...** Boston: Heath, 1864. First edition, second printing. 16mo, original blindstamped brown cloth; front cover lettered in gilt. 31, (1) pages; 8 engraved plates of bank note design elements, with original tissue guards, interspersed in the text, plate 6 serving as a frontispiece, plate 4 printed in red ink, and plate 8 printed in green ink. The testimonials have grown from one to five pages in this printing, the latest being dated Nov. 1, 1864. Near fine, with a small tear to the spine cloth at the head. **\$250**

Newman 1-P-2. A very well-preserved copy of this early printing. Better than the copy in the Newman Library.

Rare & Unusual Edition of Heath

386 Heath, Laban. **HEATH'S INFALLIBLE COUNTERFEIT DETECTOR AT SIGHT...** Boston: Heath, 1864. First edition, no stated printing or imprint. 16mo, original blindstamped brown cloth; front cover lettered in gilt, without price. 32 pages; 10 engraved plates of bank note design elements, with original tissue guards, interspersed in the text, with plate 6 serving as a frontispiece, plate 4 printed in red ink, plate 8 printed in green ink, an unnumbered plate being an engraved folding Heath bank note facsimile, and a final unnumbered plate being a folding facsimile of a counterfeit \$5 Bank of Orleans note taken from captured engraved plates. Minor wear; near fine. **\$500**

Newman 1-P-20. An unusual issue. Eric P. Newman wrote of it that "This printing may be from handset type instead of stereotype." It could have been issued at any time after Newman 1-P-3, as it includes the two unnumbered folding plates, but before Type 2-P. It is also the only variety of the first edition not printed throughout within double borders. The lack of a price on the front cover would suggest that it fell later in the lifetime of the first edition. Quite rare. Ex Heather Hardin-Hudson Library.

Twelfth Edition Heath Counterfeit Detector

387 Heath, Laban. **HEATH'S INFALLIBLE GOVERNMENT COUNTERFEIT DETECTOR, AT SIGHT...** Boston and Washington: Heath, 1877. Twelfth edition, second printing. 16mo, original blindstamped green cloth; front cover decoratively lettered in gilt. Engraved title preceding printed title; 47, (1) pages, including new prefatory chapter, "A Few Hints to Aid in Detecting Counterfeit Money," by George W. Casilear, which now appears before Chapter 1; 10 engraved plates depicting the right-hand sides of United States Notes and National Currency respectively in \$1, \$2, \$5, \$10, \$20, \$50 and \$100 denominations, followed by three new plates depicting the right-hand sides of the backs of the National Currency notes of the \$2 and \$5, \$10 and \$20, and \$50 and \$100 denominations, all printed in green and black; unnumbered advertising pages including ones for Heath's magnifiers (with one illustration). Fine, with few signs of wear. **\$300**

Newman 12-P-2. A very nicely preserved Heath Pocket edition. Superior to the copy in the Newman Library.

Bement Collection of Colonial Paper Money

388 Henkels, Stan V. **AN IMPORTANT COLLECTION OF COLONIAL AND CONTINENTAL CURRENCY, BEING THE COLLECTION FORMED BY WILLIAM P. BEMENT OF PHILADELPHIA AND A SMALL LOT FROM ANOTHER SOURCE.** Philadelphia, June 4, 1925. Tall 8vo, original printed card covers. 34 pages; 399 lots. Partly priced, with some annotations. Covers discolored; text block detached from spine. Very good or so. **\$100**
Adams 15 in the "Miscellaneous" chapter of *United States Numismatic Literature*, Volume II, rating the sale B+ overall and A in the area of colonial paper money. Henry Chapman's copy, with his signature and address on the front cover. Chapman's annotations are not extensive, but in certain places are quite detailed. An interesting copy of a very scarce catalogue.

Limited Edition Husak Catalogue

389 Heritage Auctions. **THE WALTER J. HUSAK COLLECTION.** Long Beach, February 15, 2008. 4to, original black boards, gilt; jacket; housed in black cloth slipcase as issued. (18), 414 pages; 2000–2300 lots; illustrated throughout in color. Special bookplate signed by Husak, Mark Borckardt, Denis Loring and Greg Rohan affixed to flyleaf. Fine. **\$100**
The Limited Library Edition of this very important sale of U.S. large cents. No. 35 of only 100 issued. Ex John Dannreuther Library.



1859 Hodges on Genuine Bank Notes

390 Hodges, J. Tyler. **HODGES' GENUINE BANK NOTES OF AMERICA. THE ONLY ORIGINAL AND CORRECT WORK EVER PUBLISHED, EXCEPT THE BANK NOTE SAFE-GUARD, GIVING PLAIN, SUCCINCT, AND RELIABLE DESCRIPTIONS OF EVERY GENUINE BANK NOTE OF EVERY DENOMINATION ON EVERY BANK IN THE UNITED STATES & CANADA...** New-York: 1859. 4to [29.5 by 22.5 cm], later brown half morocco, gilt, with brown linen sides; original blindstamped dark brown cloth, gilt-stamped with title, trimmed and mounted on front board; spine with two raised bands, ruled and lettered in gilt. 39, (1) pages. A worn copy, with staining throughout and some marginal repairs; an area of about two square inches is clipped out of one leaf. Good only, but in a handsome binding. **\$600**
Exceptionally rare, lacking from the Fuld, Champa and Bass Libraries.

This interesting volume was published by Hodges in lieu of the usual *Bank Note Safe-Guard* for 1859, and is very rarely seen, with the examples from the Newman and Ford Libraries being the only other copies of which we are aware to have appeared in a numismatic auction. Not listed in Sigler or the American Numismatic Society *Dictionary Catalogue*. Dillistin page 144: "This publication followed the same format as that of Thompson's list. Apparently they both first appeared in 1859. Just who was the originator of this type of publication is not known. While it appears that Thompson issued at least thirty-one editions of his descriptive list, only one edition of Hodge's list was found." Ex Heather Hardin-Hudson Library, previously in the Michael Sullivan Library (February 2017 Charles Davis sale, lot 614).



Original Coin Scale Advertising Placard

391 Infallible Coin Scale Co. **THE INFALLIBLE COIN SCALE: RENDERS THE DETECTION OF COUNTERFEITS CERTAIN.** Printed advertising placard [26.5 by 20.5 cm], mounted on red wooden shingle [29 by 24 cm] with wall mount on rear. Marginal chipping to top of placard; some roughness to shingle, especially at lower right. An eye-catching display item that is for the most part well-preserved. **\$300**

A fun piece of numismatic wall art. The advertisement ran in 1882 in *Harper's Weekly*, and is depicted in Eric P. Newman and A. George Mallis's 1999 *U.S. Coin Scales and Mechanical Counterfeit Detectors*, the main work on the subject (on page IV-2-8), but appears to have also been distributed as a wall sign: a similar example was sold in the John J. Ford, Jr. sale, Part XXIII, lot 22991. Ex Heather Hardin-Hudson Collection.

Group of Kabealo Catalogues

392 Kabealo, Samuel J. **NUMISMATIC AUCTION CATALOGUES.** Pasadena, 1956–1968. Thirty-three catalogues. 8vo, self-covered, or with printed paper or card covers, as issued. Generally near fine. **\$100**

Seldom-encountered sales issued by this prolific dealer, for whom Gengerke lists some 148 catalogues. Ex John Dannreuther Library.

The Deluxe Bass Library Catalogues

393 Kolbe, George Frederick. **THE HARRY W. BASS, JR. NUMISMATIC LIBRARY. PARTS ONE–FOUR.** Crestline & Long Beach, 1998–2000. Four volumes. 4to, original matching green Japanese cloth, lettered in black and a second color; decorative headbands; two silk ties in each volume; speckled page

edges; original printed card covers mounted on front covers; Bass ex libris mounted on rear covers; clear plastic dust wrappers throughout; Sale 3 addendum laid in. 140, (2); 175, (1), (2); 147, (1), (2); 171, (1), (2) pages; 500 + 650 + 651 + 600 lots; frontispiece portraits; numerous color and monochrome text illustrations throughout; prices realized lists; individual indexes; cumulative index. Fine. **\$200**

A set of Bass Deluxe Hardbound Editions. Limited to 90 sets, available only by subscription. Kolbe Sales 75, 77, 78 and 80.

The Hardcover Ford Library Sales

394 Kolbe, George Frederick [in association with Stack's]. **NUMISMATICA AMERICANA. THE JOHN J. FORD, JR. REFERENCE LIBRARY. PART ONE.** Riverside, June 1, 2004. 4to, original tan cloth, gilt; original printed card covers bound in. 308 pages; 1000 lots; prices realized list bound in. Fine. [with] **NUMISMATICA AMERICANA. THE JOHN J. FORD, JR. REFERENCE LIBRARY. PART TWO.** Long Beach and Crestline, June 4 and 6, 2005. 4to, original tan cloth, gilt; original printed card covers bound in. 172 pages; 1750 lots; prices realized list bound in. Fine. **\$100**

The regular hardbound editions of both Ford sales, available only to the subscribers to Kolbe's regular hardcover editions (ten additional copies of the first sale were distributed among those who proofed the initial draft of Part I).

Earliest Known Illustration of a U.S. Coin and First \$ in Print

396 Lee, Chauncey. **THE AMERICAN ACCOMPTANT; BEING A PLAIN, PRACTICAL AND SYSTEMATIC COMPENDIUM OF FEDERAL ARITHMETIC; IN THREE PARTS: DESIGNED FOR THE USE OF SCHOOLS, AND SPECIALLY CALCULATED FOR THE COMMERCIAL MERIDIAN OF THE UNITED STATES OF AMERICA.** Lansingburgh: Printed by William W. Wands, 1797. 12mo, original full brown calf; black morocco spine label, gilt. Frontispiece engraving by A. Reed of coins in current usage in the U.S.; 297, (15) pages. Moderate browning. Early ownership signature and doodles on front flyleaf. Very good. **\$350**

This early American accounting and bookkeeping manual contains what is generally believed to be the first appearance in print of the dollar sign (\$). It also includes, as a frontispiece, an engraving depicting a 1795 U.S. eagle, which Eric Newman has called "the earliest known illustration of a United States coin." Also included on the engraving are the Spanish pistole, French "guinea," British guinea, and Portuguese Johannes and half moidore. The book consists of a series of practical lessons for clerks. The dollar sign, which appears on page 56 for the first time and then throughout the volume, is a typographical approximation based upon the handwritten dollar sign used by some during the period. It resembles our own, but also differs from it. Much as a typographical ampersand is much more stylized than most of our handwritten ampersands, this initial attempt at a dollar sign in type is less a strict representation of the handwritten sign than an attempt to establish a similar sign for more formal treatment in type. A scarce volume, of exceptionally high importance. For a fascinating, if at times controversial, overview of the history of the dollar sign, see Eric P. Newman's "The Dollar Sign: Its Written and Printed Origin" in *America's Silver Dollars* (New York: ANS, 1995). Evans 32366: "It is claimed that this work was the first to use the dollar mark, \$." Howes L196 (aa): "First book to adopt the dollar sign." Ex Dan Freidus Library.

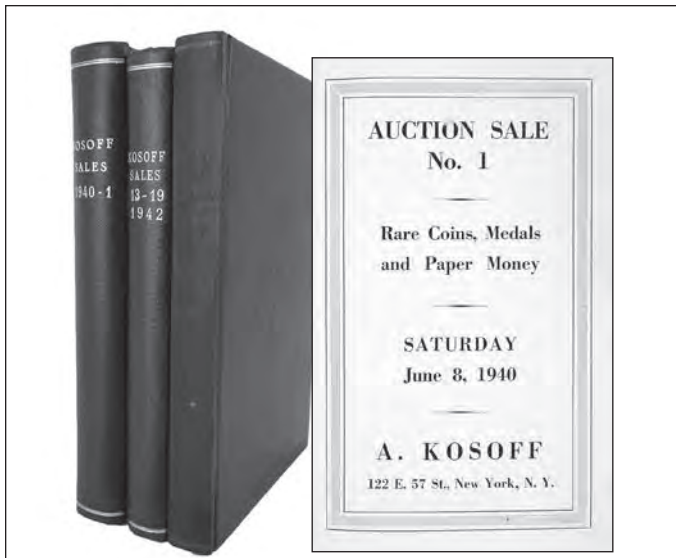

Boyd's Set of Kosoff's Early Sales

395 Kosoff, A., and Abner Kreisberg [Numismatic Gallery]. AUCTION SALE CATALOGUES. NUMBERS 1–28. New York, 1940–1944. A complete run of twenty-eight catalogues, bound in four volumes. Three 8vo, one 4to, original matching black cloth, gilt; original printed card covers bound in throughout; prices realized lists for all sales except the first, as usual, bound in. Fine. **\$1000**

Special Collected Hardbound Edition. Ex F.C.C. Boyd, with his name stamped in gilt at the base of the upper covers. All but the first volume is inscribed by Kosoff. Only a few of these sets, bound in groups by Kosoff at the time, were issued. Though lacking the panache of his later emissions, these early catalogues reveal two factors contributing to Kosoff's success: hard work and great ambition. A third, his fabled interpersonal skills, is perhaps best understood in a response often related by John Ford. It goes something like this: *John, you don't necessarily need to know everything about a coin, you just need to know the person to whom you are selling it.* Notably present here are the long series of Julius Gutttag sales and the Higgy sale, considered by Kosoff to be the beginning of the modern coin market. Also included is a 4-page handwritten letter from Homer K. Downing to "Pvt. J.J. Ford, Jr.," stationed at Fort Monmouth, in the original mailing envelope, postmarked February 21, 1943, concerning Kosoff's February 27, 1943 sale, noting that Downing "Went down to 50th St. today and checked up on all the lots we are interested in..." After discussing the merits of several large cents, Downing goes on to provide his appraisal of a number of numismatic books of interest to Ford, including a near complete set of the *American Journal of Numismatics*, and a number of plated catalogues. These were the days when plated copies of Elder's Woodin and Gschwend sales were sold as a single lot, bringing all of \$2.75 according to the prices realized list. Downing seeks Ford's advice on a number of lots in the sale and also notes that he "Can buy a brand new copy of Maris Jersey Cents from H.C. H. [Hines]. What is it worth. Let me know soon while he is in the mood. He also has a Gem Silver Proof Set of 1864... What should I give him for it?" A postcard from Abe Kosoff dated August 27, 1943, addressed to "Pvt. Ford," is also present, advising him that his "copies of the Higgy catalog were mailed out on August 19th and should have reached Rockville Centre by this time." Ex John J. Ford, Jr. Library (Kolbe Sale 93, lot 626, at \$900 hammer); ex John Dannreuther Library.

An Original Set of Loubat

397 Loubat, J.F. THE MEDALLIC HISTORY OF THE UNITED STATES OF AMERICA, 1776–1876. VOLUME I: TEXT. VOLUME II: PLATES. New York: Published by the Author, 1878 [plates] and 1880 [text]. Two volumes. Folio, original matching orange cloth, gilt. lxxix, (1), 478, 8; xvi pages; titles printed in red and black; 170 finely engraved etchings of medals by Jules Jacquemart on 86 plates with tissue guards. Covers only lightly stained; text volume's spine cloth torn near tail. Interiors fine. **\$250**

An original set of perhaps the most lavishly executed work on American numismatics ever published. The author relates in the introductory text "that Mr. Jefferson, as early as 1789, entertained the idea of publishing an account of all American medals, struck up to that time," but it remained for Loubat to publish the first extensive work on the topic. In 1908, the *American Journal of Numismatics* noted: "His sumptuous work on the Official Medals struck by the authority of the United States marked an epoch in our medallic history." The text volume here present is the scarcer 1880 printing, which seems only to affect the title page. Clain-Stefanelli 15073*. Davis 631.

Quarterman Reprint of Maris, with Auerbach

Photo

398 Maris, Edward. A HISTORIC SKETCH OF THE COINS OF NEW JERSEY.... Lawrence: Quarterman, 1974 reprint. Folio, original blue cloth, gilt; jacket. viii, (2), 21, (1) pages; fine double-page plate. Jacket spotted; volume fine. Laid in is a copy of the Mark Auerbach reproduction of the first photograph of Edward Maris to be identified as such, along with Auerbach's description of it. Fine. **\$100**

The high-quality reprint of Maris, featuring an excellent reproduction of the plate and a price guide. The photo of Maris reproduced in limited numbers by Auerbach was the first photo of Maris to be identified as such. Ex Roger Persichilli Library.

Very Scarce Maine Price Lists

399 Marks, A.E. CATALOGUE OF COINS, CURRENCY & INDIAN RELICS. Woodfords, 1892 (or later). 8vo, self-covered. 12 pages. Folded for mailing. Very good. [with] Marks, A.E. A LIST OF COINS IN STOCK AND FOR SALE. Woodfords, 1895 (or later). 12mo, self-covered. 30 pages; errata slip. Very good. [with] Marks, A.E. A LIST OF COINS IN STOCK AND FOR SALE. Portland, 1899. 8vo, original printed brown paper covers. 27, (1) pages. Near fine. **\$100**

Three late 19th-century numismatic publications from this Maine dealer. Very scarce. Ex Roger Persichilli Library.

Mason's Final Magazines

400 Mason & Co. MASON'S COIN COLLECTORS' MAGAZINE AND PRICE CURRENT. NEW SERIES. Volume XIII, Nos. 1–3 and Volume XIV, No. 1. Boston & Philadelphia, June 1890 to March 1891. Four issues, complete. Tall 8vo, original printed paper covers. 20 + 12 + 12 + 12 pages; a few lithographic illustrations in the first issue. Some staple rust; final issue with chipped corner to cover. Generally near fine. **\$150**

All issued. The first two numbers were published in Boston, the last two in Philadelphia. After the second issue, "New Series" on the front wrapper is dropped from the masthead; with the third issue "Collectors" becomes "Collector's" and "Price Current" is moved to the lower half of

the cover, revised to read "Coin Price Current." The drop-title remains "Mason's Coin Collectors' Magazine" throughout. Mason's phoenix-like series of periodicals spanned nearly a quarter century, comprising by his reckoning a total of fourteen volumes. These final two volumes rarely appear for sale (the last one isn't even listed by Bourne). Though he lived another decade, his last coin auction sale was held in Boston in June 1890. The move to Philadelphia late in the same year apparently pre-figured his departure from commercial numismatics. In the final March 1891 issue of the magazine he advertises for a "Partner Wanted," who would "take an indoor position in our store, near the U.S. Mint... the duties of outside coin collecting, in both hemispheres, and absence during the summer months of the present proprietor renders it necessary that an assistant (only as a full partner) is necessary." The impression of an idle dilettante making grand tours of the Continent sadly appears to be at odds with reality. In Mason's obituary appearing in the January, 1902 issue of the *American Journal of Numismatics*, his colleague Lyman Low wrote in closing: "He was a man of energy and upright in all his dealings, and though the latter years of his life were not crowned with the success which human judgment thought he had deserved, he left a large circle of friends who will ever cherish his memory." John Adams's paean to the man also bears repeating: "Ebenezer Mason did a great deal to promote numismatics and to push back the borders of its ignorance. His enthusiasm was, commercially speaking, poorly compensated. However, one often senses in his writings that he was speaking to posterity. Perhaps, he realized that many of his contributions would survive and the immortality so envisioned served to soften the hardships of financial failure."

1781 Act Regarding 1780 Bills of Credit

401 Massachusetts, Commonwealth of. AN ACT FOR REPEALING CERTAIN PARTS OF AN ACT POSTPONING THE PAYMENT OF GOVERNMENT SECURITIES TO A DISTANT PERIOD, FOR THE PAYMENT OF THE INTEREST NOW DUE ON SAID SECURITIES, AND FOR ALTERING THE SEVERAL ACTS OF GOVERNMENT WHICH NOW RELATE TO THE CURRENCY OF THE STATE AND CONFORMING THE SAME TO THE PRINCIPLES OF EQUALITY AND JUSTICE. (Boston: Benjamin Edes & Sons), 1781. 7, (1) pages. Unbound and unstitched. Outer edges a trifle chipped and stained. **\$100**

A very rare Massachusetts Act amending the May 5, 1780 Act authorizing "Bills of Credit not to exceed the sum of Four Hundred and sixty Thousand Pounds." Signed in type by Caleb Davis, Jeremiah Powell, John Hancock and John Avery. Evans 17216 (second title). Sabin 45561. Newman page 215. Ex John Carter Brown Library (envelope in which it was deaccessed included); ex Kolbe Sale 57, lot 277; ex Dan Freidus Library.

Frank Duffield's Inscribed Presentation Copy

402 Mehl, B. Max. THE CELEBRATED COLLECTION OF LARGE UNITED STATES CENTS FORMED BY DR. GEO. P. FRENCH... Fort Worth, (1930). 4to, later green cloth, gilt; original printed brown card covers, with Frank Duffield's name printed on them, bound in. 139, (1) pages; 823 listings; halftone text illustrations of large cents. Signed by Mehl on the first leaf to Duffield and dated May 12, 1930. Near fine. **\$100**

Mehl's famous fixed price catalogue of this major collection. This is a presentation copy, being the regular card-covered edition, but with the recipient's name printed on the front cover and inscribed by Mehl. Duffield served as President of the American Numismatic Association from 1913 to 1915. Ex Roger Persichilli Library.



The B. Max Mehl "Star Building"

403 Mehl, B. Max. A SUITE OF SIX COLOR PHOTOGRAPHS DEPICTING THE "STAR BUILDING" OF FORT WORTH, TEXAS. Commissioned by Armand Champa, July 15, 1992. All 8.5 by 11 inches. Loose. Fine. **\$100**

Commissioned by Armand Champa and taken by a local photographer in 1992, these photos show the Mehl Building as it existed at that time, long after the heyday of the erstwhile proprietor. Included are photos of: 1) the main doorway, Mehl's nameplate above, with Fugio copper over the door and recessed, intricate stone archway, all rendered poignant by a few missing letters in Mehl's name and the weeds impinging on the entryway; 2) the secondary doorway, with the numismatic image of an eagle with shield and arrows above it; 3) the entire long side of the three-story building with Mehl's office entries at the left; 4) a closer view of the preceding, emphasizing the decay (missing and boarded-up windows, etc.); 5) a view of both entries with two numismatically appointed windows between them; and 6) a view of the short side of the building to the right of the preceding views, with graffiti on the walls and boarded-up doors, it originally was the main entrance to the non-Mehl portion of the building.

The Official 1934 ANA Convention Sale

404 Molnar, Charles J. AMERICAN NUMISMATIC ASSOCIATION. PROGRAM AND CATALOG OF COINS TO BE SOLD AT AUCTION. Cleveland, August 20, 1934. 12mo, original printed card covers. 23, (1) pages; 590 lots. Very good. **\$150**

A scarce catalogue. Although it was clearly the official convention sale, Charles Fisher conducted an auction three days later. While the days leading up to an A.N.A. convention are now packed with important coin auctions, this was a notable innovation at the time. Ex John Danreuther Library.

Morin on Indian Peace Medals

405 Morin, Victor. LES MÉDAILLES DÉCERNÉES AUX INDIENS. ÉTUDE HISTORIQUE ET NUMISMATIQUE DES COLONISATIONS EUROPÉENNES EN AMÉRIQUE. Ottawa: *Tirage Spécial de l'Auteur*, The Mortimer Co., 1916. 8vo, original printed card covers. Oval frontispiece portrait of the author; 86 pages; 31 plates depicting 48 figures, nearly all medals. Near fine. **\$200**

The first appearance in book form of this scarce and important work. The first four chapters cover medals issued by France, Great Britain, Spain and America. The fifth chapter concerns *Médailles semi-indiennes* and the final chapter, *Observations générales*, includes presentation

ceremonies, wampum collars, rarity and value, replicas, etc. The work concludes with a lengthy bibliography. Morin's outstanding collection of Indian Chief medals, the basis of this work, was acquired privately by J. Douglas Ferguson. Bowman 16. Clain-Stefanelli 14454. CNB page 656. Ex Armand Champa Library (Davis/Bowers Sale III, lot 2377); ex Roger Persichilli Library.

Morley on 1794 Cents

406 Morley, Tom. 1794 LARGE CENTS, GRADED AND UPDATED. THE LATEST INFORMATION ON THE 1794'S. PLUS FOR THE FIRST TIME A PHOTOGRAPHIC GRADING GUIDE TO THE SERIES. Cape Kennedy, 1979. 8vo, original brown cloth, gilt; original printed card covers bound in. (10), 42 pages; illustrated throughout. Fine. **\$100**

The Special Hardbound Edition. Quite scarce. Ex Roger Persichilli Library.

Ray Munde Collection of Half Cents

407 Munde, Ray. INVENTORY OF THE COLLECTION OF UNITED STATES HALF CENTS FORMED BY RAY MUNDE. File folder containing: 1) Handwritten cover letter (2 pages on legal-size ruled paper) dated June 1, 1976 addressed to Roger Persichilli; 2) photocopy of a heavily annotated copy of the 1962 *Empire Guide to United States Half Cents* (by Bowers and Ruddy), with the annotations serving as a checklist to the specimens in the Munde collection; 20 photocopied legal-size pages reproducing the index card inventory of Munde's half cent collection, generally giving not only the basic information regarding variety and grade, but where it was purchased, from whom, and at what price (though a number of the prices have been effaced). Generally fine. **\$100**

An interesting record of this notable collection, with much information relevant to provenance research in this area. Ex Roger Persichilli Library.

Near Complete Set of New Netherlands Catalogues

408 New Netherlands Coin Company. AUCTION SALE CATALOGUES NUMBERS 1-29 & 32-66. New York, 1940-1976. A nearly complete set of numbered sales, lacking only Sale 30 and 31. Varying formats, all in the original printed paper or card covers. Thirty-eight with printed prices realized lists. Generally near fine, with most of the early sales being initialed on the front cover but otherwise fine. [with] New Netherlands Coin Company. SIX MAIL-BID SALE CATALOGUES. New York, 1967-1977. Includes Adams 60b, 62a, 63a, 64a, 64b and 66a. All 8vo, original printed card covers. 62a, 64a and 64b have prices realized lists. Fine or nearly so. **\$900**

A wonderful series. As described by John W. Adams in *United States Numismatic Literature*, Volume II: "In November, 1950, Charles Wormser hired John Ford, and perhaps the most important chapter of numismatic cataloguing was begun. Sometimes abrasive but always insightful, Ford ranks in a class with Sylvester Crosby, Lyman Low, David Prosky, and Wayte Raymond as one of the great numismatists this country has produced. His cataloguing features meticulous accuracy and conservative grading; his descriptions are full and informative, covering a range of material that spans the gamut of our hobby. Others have rivaled Ford's penchant for detail, but none have better explored the by-ways of history and tradition for which numismatics are such a natural entry. As if one world-class numismatist were not enough, New Netherlands

hired Walter Breen in 1952. Blessed with a restlessly inquiring mind and a prodigious memory, Breen added new dimensions to the firm's research. His findings on die states, diagnostic features and the then condition census add another rich layer to the utility that New Netherlands' catalogues will always possess... Sale 1 through 25 are either scarce or, in a few cases, rare... The New Netherlands catalogues represent something special in American numismatics. They demonstrate with eloquence that the business of dealing in coins can also embrace the functions of educating the collector and preserving the traditions of the hobby. In so doing, the members of the firm have set an example which, though rarely observed, will nonetheless act as a beacon to the profession in years to come." The condition of the early catalogues in this group is particularly fine. Ex Roger Persichilli Library.



Plated R. Coulton Davis Sale, ex Ford

409 New York Coin & Stamp Co. CATALOGUE OF THE COLLECTION OF COINS, MEDALS, TOKENS AND CURRENCY FORMERLY OWNED BY THE LATE ROBERT COULTON DAVIS, PH.G., OF PHILADELPHIA, PA. NOW OWNED BY A PRIVATE GENTLEMAN. New York, January 20-24, 1890. 4to, original flexible black cloth; upper cover lettered in gilt. (2), ii, (3)-128, (2) pages; 2914 + bis lots; 4 fine tinted photographic plates; printed slip in red ink providing the place and date of sale and other pertinent details tipped in to title. Neatly hand-priced throughout in red ink. Spine ends a trifle worn. Near fine. **\$750**

Adams 3. An exceptionally well-preserved example in the original cloth covers. This outstanding catalogue of American coins is highlighted by Davis's pattern holdings, which provided the foundation for his pioneering listing of the series serialized in the *Coin Collector's Journal* in the mid-1880s. The first plate depicts gold coins: ancient Roman and Byzantine, a Brasher doubloon, and United States gold coins. The second plate illustrates rare United States silver coins (1794 dollar, 1796, 1797 and 1838-O half dollars, rare Seated Liberty dollars), and the third plate depicts colonials, half cents, large cents, and other copper rarities (a Baker 288 Masonic medal in brass, a Non Vi, exceptional large cents and the 1794 dollar in copper). The final plate is devoted to important colonials, United States, and foreign silver coins (1802 half dime, NE shilling, etc.). Rated A+ by Adams: "Magnificent sale. 1838-O 50¢. 1875 proof gold. Superb patterns: copper 1794 \$1, 1879 \$20. 1876-CC 20¢. Brasher doubloon." Ex John J. Ford, Jr. Library (Kolbe Sale 93, lot 718, at \$900 hammer); ex John Dannreuther Library.

1831.	
35-	1003 Half Eagle: fine, sharp proof; a decided rarity.
11-	1004 Quarter Eagle: sharp and perfect proof; rare.
10-	1005 Half Dollar: barely circulated.
10-	1006 Quarter Dollar: large letters in legend; fine sharp proof.
1-	1007 Quarter Dollar: small letters in legend; barely circulated; proof surface.
325	1008 Dime; very fine, sharp proof.
325	1009 Half Dime; very fine, sharp proof.
11-	1010 Cent: small letters in legend: stars rounded to l.; otherwise sharp; proof surface on obv., B. red and uncirc.
22	1011 Cent: same dies: stars flattened: otherwise sharp and uncirc; red.
23-	1012 Half Cent: original: sharp, perfect proof; rare.
1832.	
35-	1013 Half Eagle: six stars rounded: otherwise sharp, uncirc; extremely rare.
750	1014 Quarter Eagle: sharp; faintest traces of circulation.
1150	1015 Half Dollar: sharp, perfect proof; scarce.
13-	1016 Quarter Dollar: sharp, perfect proof; scarce.

Plated Parmelee Sale, Priced & Named

410 New York Coin & Stamp Co. CATALOGUE OF THE FINEST EXISTING COLLECTION OF AMERICAN COINS, THE PROPERTY OF MR. LORIN G. PARMELEE, OF BOSTON, MASS. New York: Bangs & Co., June 25–27, 1890. Tall 8vo, disbound, retaining original gilt-lettered black calf spine and the original gilt-printed paper front cover, detached. 96 pages; title printed in blue, black and red; 1443 lots; fine portrait of Parmelee; 13 fine tinted photographic plates. Handpriced throughout in pencil and ink, with buyers' names or initials indicated by each lot, and with occasional additional annotations. Good only, but improvable. **\$1500**

A saleroom copy of this rare and important catalogue, with the full complement of plates, and annotated with priced and names recorded. An outstanding sale, rated A+ by Adams: "Absolutely definitive for patterns, colonials (several unique), and regular issue gold, silver and copper." Parmelee's remarkable collection has frequently been regarded as the finest collection of American coins ever formed. One hundred copies were issued with plates (though most haven't survived), attractively tinted to approximate the metal color of the coins depicted. The presentation of the Federal issues is unusual. Arranged chronologically rather than by denomination, this innovation was not well received at the time, and has seldom been used since. A famous and highly successful Boston bean baker, Parmelee began collecting coins by sorting through the large cents from his daily receipts. He sold duplicates but continually upgraded his personal collection. In his first major coup, he purchased the superb collection formed by George F. Seavey, which was slated to be sold at auction. He acquired the Brevoort collection in 1876, the magnificent Bushnell collection in 1882, and purchased many rarities from Sylvester Crosby. The first two plates illustrate copper patterns and colonials; plates 3 and 4 depict silver patterns and colonials; plate 5 illustrates copper colonials and Washingtonia; plate 6 is mainly devoted to early cents and half cents; plates 7 and 8 largely depict superb early United States silver coins; plates 9 and 10 are devoted to choice cents and half cents; plates 11 and 12 mainly illustrate United States and gold patterns, including a Brasher doubloon; and the final plate is devoted to large denomination nineteenth-century United States silver coins. Copies with the buyers' names recorded (even in abbreviated form, as here) are rare and very useful for provenance research. Buyers included Clay, Ropes, Hall, Newlin, Warner, Jenks, Mougey, Wilson, Mills, Crosby, and many others, in addition to virtually all of the major U.S. dealers of the day. Ex John J. Ford, Jr. Library (Kolbe Sale 93, lot 719); ex John Dannreuther Library.

Original Newcomb on 1801–1803

411 Newcomb, Howard R. THE UNITED STATES CENTS OF THE YEARS 1801–1802–1803. Detroit, 1925. 4to, original brown cloth, gilt. 85, (1) pages; 5 fine photographic plates; addition slip tipped in on page 73. Without the usually seen marker. Nearly fine. **\$150**

One of the major pre-Sheldon works on U.S. large cents. Usually encountered with a silk marker, to the end of which is appended what has always been described as a "cent gauge," despite the fact that it isn't the size of a large cent and serves no readily apparent purpose. Davis 745. Voted as one of the Numismatic Bibliomania Society's "One Hundred Greatest Items of United States Numismatic Literature." Ex William & Elizabeth Wisslead Library (Bergman Sale 5, lot 632); ex Roger Persichilli Library.

Leatherbound Newcomb on Regular Paper

412 Newcomb, Howard R. UNITED STATES COPPER CENTS, 1816–1857. First edition. New York: Numismatic Review, 1944. 4to, original full red processed leather, gilt. 284 pages; 11 plates. Printed on regular paper. Spine and extremities rubbed, as usual; very good or better. **\$120**

The deluxe, regular-paper, leatherbound version of the first edition of this important work. Only 125 deluxe copies of Newcomb's final book were bound in leather, 50 on regular paper (as here) and 75 on thick-paper. In both cases, the leather used was of inferior quality, and scuffs easily. Completed four years earlier, Newcomb's work was not published until 1944 due to the war. One thousand copies were printed. It marked a great improvement over the pioneering work of Frank Andrews, nearly doubling the variety listings, and stood as the standard work for half a century. The result of many years of painstaking study, relatively few new varieties were discovered in the intervening years. Dr. Sheldon noted that "Newcomb's book doubtless achieves the highest pinnacle for numismatic completeness." Voted as one of the Numismatic Bibliomania Society's "One Hundred Greatest Items of United States Numismatic Literature." Clain-Stefanelli 12326. Ex Roger Persichilli Library.

Inscribed First Printing of The Fantastic 1804 Dollar

413 Newman, Eric P., and Kenneth E. Bressett. THE FANTASTIC 1804 DOLLAR. First printing. Racine: Whitman, 1962. 8vo, original brown textured cloth lettered in silver. 144 pages; illustrated. Inscribed and signed by both authors on the front flyleaf in the year of publication. Fine. **\$300**

The scarce first printing of this classic work, copies of which are more accurately considered bound page proofs issued in very small numbers immediately before the presses were fired up to print the entire run. Indeed, this copy is identified by the authors as exactly that: "Bound page proofs in need of correction," reads the inscription dated Sept. 12, 1962 and signed by both Newman and Bressett. The backstory behind this volume is the stuff of numismatic legend. Newman and Bressett's work had led them to the conclusion that the story of sets of 1834 and 1804 coins being issued for the Imam of Muscat and the King of Siam were myths—there was no evidence of such gifts having been issued. The book was due to be printed during the 1962 ANA convention, at which the discovery of the King of Siam set (including the 1804 dollar) was announced by David Spink and James Risk. This announcement elicited a frantic application of editorial brakes, as Newman and Bressett had to accommodate this new information and revise their publication to take it into account. What turned out to be an outstanding numismatic work could have been issued with a major flaw had it been prepared in time

to be on sale at the ANA. See the extensive article by Len Augsburger and Joel Orosz in the Winter 2020 edition of *The Asylum*. A popular item, these have always been considered quite rare, though the presence of half a dozen or so of them in the Newman Library made them somewhat more available. Ex Eric P. Newman Library.

Classic Work on Massachusetts Silver

414 Noe, Sydney P. **THE SILVER COINAGE OF MASSACHUSETTS**. Lawrence: Quarterman, 1973 reprint. 8vo, original blue cloth lettered in silver; jacket. xiv, (4), 246 pages; illustrated. Jacket clipped, else fine. **\$100**

The collected edition of Noe's three major monographs, including extracts from Eric Newman's work on the Good Samaritan shilling, with an added foreword and biographical sketch of Noe. Still indispensable.

Early Numismatic Society Publications

415 Numismatic Society of Philadelphia / Numismatic and Antiquarian Society of Philadelphia. **TWENTY-SEVEN PUBLICATIONS BOUND IN ONE VOLUME**. Philadelphia: 1858–1889. Includes *Constitution and By-Laws*, 1858; *Charter, Constitution, By-Laws* (3 editions: 1865, 1870, 1883); *Proceedings of the Society* (10 editions: May 4, 1865 to December 31, 1866 with the \$3 order form dated May 3, 1867 bound in, 1878–1879 combined, and for the years 1880, 1881, 1882, 1883, 1884, 1885, 1886, and 1887–1889); *Circular Relating to a Proposed Archaeological Map; To the Memory of Hon. William Willis, LL.D.*, 1870, by Charles Henry Hart; *Memoir of George Ticknor*, 1871 by Charles Henry Hart; *Presentation of a Silver Medal to Eli Price*, March 20, 1879; *On Falsifications of Ancient Coins*, 1879, by S.K. Harzfeld; *Act and Bull*, 1880, by Lewis Scott; *Some Modern Monetary Questions*, 1880, by Robert Toppan; *The Remains of an Aboriginal Encampment at Rehoboth Delaware*, 1880, by Francis Jordan; *Old and New Style Fixed Date Calendars*, 1881, by John Baker; *William Penn's Landing in Pennsylvania*, 1881; *William Beach Lawrence*, 1881, by Charles Henry Hart; *The Books of Chilan Balam*, 1882, by Daniel Brinton; *Proceedings... of the 25th Anniversary Celebration*, January 1883. 8vo, later brown calf and marbled boards, gilt; spine with five raised bands. Spine and edges worn; very good. **\$300**

The official published records of the oldest numismatic organization in the country, complete for the period 1858–1889, along with several publications read before the Society. With the bookplate of C. Howard Colket, who joined the society in 1893 and served as its librarian from 1912–1919. Colket noted that this volume was bound on April 7, 1909 for the cost of \$1.50. Founded in January 1858, three months before the formation of the American Numismatic Society, the Numismatic Society of Philadelphia was created when eight local numismatists “who had long felt the want of such an association, organized a society for the purpose of prosecuting their favorite study in a more systematic and satisfactory manner. The mania for coin collecting was then raging fiercely, and desires had arisen with very many persons to become better acquainted with the science” — *Proceedings*, 1867.

Bid Book for Proskey's First Sale

416 Proskey, David. **CATALOGUE OF PART OF A PRIVATE COLLECTION OF COINS AND MEDALS**. New York, September 14–15, 1876. 8vo, original printed paper covers. 54, (2) pages; 1232 lots. Annotated throughout in pencil, including prices realized and buyers' names or initials, along with other computa-

tions and notes. Covers a bit discolored. Near fine. **\$250**
Proskey's bid book. Unique. “Private DP” written in ink on upper cover. The first of only five sales held by Proskey, who was perhaps, according to John Adams, “the most talented numismatist the United States has produced.” Also included are two sheets of sale computations, the original \$98.50 printer's invoice for “500 coin catalogues,” and the handwritten statement of Bangs, Merwin, the auction house conducting the sale, recapping charges of \$65.51 for conducting the sale, marked “Paid” by Proskey. Ex John J. Ford, Jr. Library (Kolbe Sale 93, lot 756); ex John Dannreuther Library.

Priced & Partly Named Wilson Sale I

417 Raymond, Wayte. **THE IMPORTANT NUMISMATIC COLLECTION FORMED BY THE LATE W.W.C. WILSON, MONTREAL, CANADA. UNITED STATES & CANADIAN COINS, EARLY AMERICAN & CANADIAN HISTORICAL MEDALS, MEDALS PRESENTED TO NORTH AMERICAN INDIAN CHIEFS, FOREIGN COINS & MEDALS**. New York: Anderson Galleries, November 16–18, 1925. 8vo, later red cloth, gilt. 92, (2) pages; 1260 lots; text illustrations. Heavily annotated throughout with prices realized and many buyers' names written in ink next to each lot. Very good or better. **\$300**

Adams 9 (rated A+ overall, and for early medals, U.S. medals and Canada in particular). Of immense importance for early North American medals and coins, with the first sale including nearly complete series of Franco-American jetons and Side-View tokens, and numerous individual rarities (the Tuesday Club medal, Happy While United medal, Washington peace medals, Quaker peace medal, Society of Tammany medal, gold Erie Canal medal, etc.). Other impressive content in the first sale includes a nearly complete collection of U.S. fractional currency and the Maris 64.5-r New Jersey copper (now termed 65.5-r and unique in private hands). It is one of the most important catalogues of North American material ever produced. This variant does not include the halftone plates (one single and one double) found in most copies of the regular edition. Davis 860.

The Charles P. Senter Collection

418 Raymond, Wayte. **EARLY AMERICAN HISTORICAL MEDALS. MEDALS PRESENTED TO INDIAN CHIEFS. ORDERS OF CHIVALRY, ART MEDALS AND PLAQUES. COLLECTION OF THE LATE CHARLES P. SENTER**. New York: American Art Association, October 27, 1933. 8vo, original printed card covers. (8), 32, (2) pages, including 4 plates; 248 lots. Near fine. **\$100**

Adams 16. Rated A+, overall: “Hurriedly written but a landmark medal sale. Betts series: Matanzas, Albemarle, Oglethorpe, 285 Vernons. U.S. Series: Stewart, De Fleury, Felicitas Britannia. Rich in peace medals: ‘Happy While United,’ 1793 oval Washington, Astor and many more.” Ex Richard E. Margolis Library.

A Complete Set of Ruddy's Review

419 Ruddy Investments. **RUDDY'S REVIEW**. Numbers 1–4, complete. Hollywood, February–November 1970. 8vo, self-covered, as issued. 80 pages, total; illustrated. Near fine. **\$200**

A most elusive series of fixed price lists. The first set to appear at public sale sold in the July 30, 1990 Money Tree sale for \$525 and Ken Lowe noted therein that “*Ruddy's Review* is so scarce that few collectors of numismatic literature are even aware of its existence.” At the time of publication, James F. and Nancy Ruddy were located in Hollywood “directly across from the famous *Grauman's Chinese Theatre*.” After the

brief interregnum documented by the *Reviews*, they once again joined forces with Q. David Bowers, and it was here, in the glory days of the 1970s, that the firm started their march to the front ranks of commercial American numismatics. Given their modest appearance, few examples of *Ruddy's Review* were saved, and complete sets remain quite rare.

The Day the Mint Opened

420 San Francisco Daily Herald. **COMPLETE ISSUE OF A SAN FRANCISCO NEWSPAPER, WITH NUMISMATIC CONTENT, PUBLISHED ON THE DAY THE SAN FRANCISCO MINT OPENED.** Volume IV, Number 305. San Francisco, Monday Morning, April 3, 1854. Large tabloid. 4 pages. Folded; some spotting. Spine a bit ragged, but holding. Very good. **\$150**
A San Francisco newspaper published the very morning the San Francisco Mint opened its doors for business. While the opening is not discussed, the paper includes a report on page 2 regarding the deposits of gold and silver made at the Philadelphia Mint in February 1854, and the resulting coinage, noting specifically the gold that came from California.

Important 1886 Maris Sale

421 Smith, H.P. **CATALOGUE OF COLONIAL, UNITED STATES, AND PATTERN PIECES FROM THE CABINET OF DR. EDWARD MARIS OF PHILADELPHIA.** Philadelphia: Stan. V. Henkels & Co., June 21, 1886. 4to, later russet cloth and marbled sides; spine label lettered in gilt; original printed paper covers bound in. 30, (2) pages; 501 lots. Separately printed preface laid in. Small tear to front paper cover, else a fine copy. worn and taped; fore-edge wear. Very good. **\$120**

A scarce sale, of enormous importance for colonial and state coinages, most especially the New Jersey coppers. Best known today for his seminal work on the New Jersey pieces, Maris also is credited with the first serious works on the die varieties of 1794 U.S. large cents. The sale appears to have generated some controversy. Maris issued a circular on May 15, 1886, announcing that his collection was to be sold at the auction house of Stan. V. Henkels of Philadelphia. Maris writes in this circular that "The most important of the Colonials will comprise my entire collection of the coins of New Jersey. This will include specimens, or copies of all known New Jerseys, of undoubted genuineness, together with some counterfeits of that period. Also, those which were struck over the Connecticut, Vermont, Nova Constellatio, English, Irish and French coppers; one in brass; one in a mixed metal; one with a small piece of silver in the plow handle; and many other pieces showing fracture of the dies." In an unusual move, Maris catalogued his collection himself. This apparently irritated some coin dealers, who resented this intrusion onto their turf. Adams 19 (rated A overall and for colonials and patterns in particular). Clain-Stefanelli 12188. Davis 944. Ex Roger Persichilli Library.

The Caldecott Sale

422 Sotheby, Wilkinson & Hodge. **CATALOGUE OF THE COLLECTION OF COINS AND TOKENS OF THE BRITISH POSSESSIONS & COLONIES FORMED BY J.B. CALDECOTT, ESQ. WHO IS RELINQUISHING THIS SERIES.** London, 11–13 June 1912. Crown 4to, slightly later blue cloth, gilt. iv, (2), 50 pages; 486 lots; 6 fine plates. Minor soiling to one corner; very good or better. **\$100**

The Caldecott sale was a notable British collection featuring rare American colonial coins (NE shilling, Bermuda pieces, etc.) in addition to other British colonials. Clain-Stefanelli 8485.

The King Farouk Coin Sale

423 Sotheby & Co. **THE PALACE COLLECTIONS OF EGYPT. CATALOGUE OF THE HIGHLY IMPORTANT AND EXTREMELY VALUABLE COLLECTION OF COINS AND MEDALS, THE PROPERTY OF THE REPUBLIC OF EGYPT.** Cairo, February 24–March 6, 1954. Crown 4to, original printed card covers. 306, (6) pages; 2798 lots; 37 plates, all but the last double-plates. Original prices realized list laid in. Spine reinforced with archival linen backing; very good. **\$150**

The famous sale catalogue of the legendary coin collection formed by King Farouk. The details surrounding the sale are fascinating and often bizarre, and were recounted in part by Abe Kosoff in a series of *Coin World* articles. Dominated by Kosoff, Hans Schulman and a handful of other East Coast coin dealers, only a few collectors attended the sale, John J. Pittman notably among them. Catalogued by the London firm of Baldwin's, great rarities from the Woodin, Earle, Colonel Green and other great American collections were often placed in group lots, e.g., a 1913 Liberty Head nickel and pattern United States gold coins. The onerous financial requirements imposed by the Egyptian Government combined with reported dealer collusion appears to have stifled widespread competition and many bargains were to be had by those brave enough to venture to Cairo. Clain-Stefanelli 8013*. Grierson 275 and 277. Ex Richard E. Margolis Library.

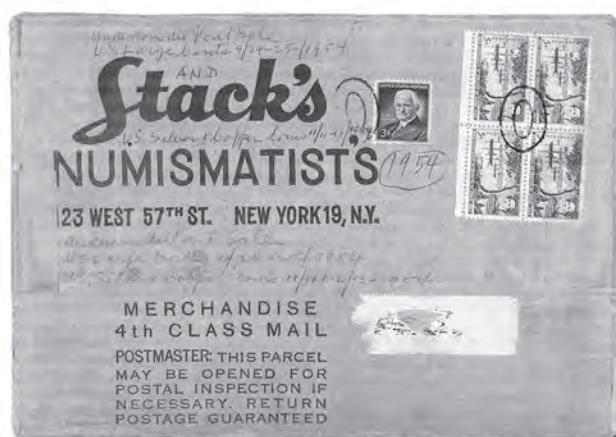

Anderson Dupont I & II in Original Mailing Box

424 Stack's. **ANDERSON DUPONT CATALOGUE. PART I: U.S. LARGE CENTS, 1793 TO 1857. [with] PART II: UNITED STATES SILVER AND COPPER COINS.** New York, September 24–25 and November 11–13, 1954. Two volumes. 8vo, original printed card covers. 92, (2) + 118, (2) pages; 2722 lots; text illustrations; plate supplement; both prices realized lists. The two together, housed in the original mailing box (23 cents worth of stamps still affixed). Fine. **\$100**

Adams A (both sales). A most important collection whose origins are still not fully known. The large cents were catalogued by Dr. Sheldon. According to interviews and research conducted by P. Scott Rubin, Charles J. Dupont was a coin collector/part-time dealer who, with the help of his next door neighbor Charles Anderson, posing as a philatelic expert, acquired the coins and a philatelic collection from an unknown eastern institution. Important segments of the collection, mostly gold coins, were sold privately through Stack's, some ending up in the Lilly collection now at the Smithsonian Institution. Ex Roger Persichilli Library.

Amon Carter Collection, Hardcover

425 Stack's. THE AMON G. CARTER, JR. FAMILY COLLECTION OF UNITED STATES GOLD, SILVER & COPPER COINS. FOREIGN COINS. New York, January 18–21, 1984. 8vo, original blue cloth, gilt; original printed front card cover mounted. (4), 316 pages; 1798 lots; portrait; text illustrations; 28 color plates; prices realized list housed in pocket on rear cover. Mounted cover a little rubbed, as always. Fine. **\$100**

The Special Hardbound Edition. A most important sale featuring, among others, coins from the Dunham, Neil, Green, Atwater, Olson, Roe, Farouk, Roach, Granberg, Newcomer and Haseltine collections. According to the firm, the collection was "highlighted by the finest and most complete collection of U.S. Silver Dollars ever to be auctioned." Additionally, the series of pioneer and territorial gold coins was "unique in its own right," featuring thirty-one \$50 slugs and many other great rarities. The first Stack's sale where the cataloguing is attributed to a single firm member, namely Norman Stack, who took great pride in this production. Ex John Dannreuther Library.

The Twin Leaf Large Cents

426 Stack's-Bowers Galleries. THE TWIN LEAF COLLECTION OF UNITED STATES LARGE CENTS. Baltimore, July 16, 2015. 4to, original black leatherette, gilt; original pictorial card covers bound in. viii, 329, (3) pages; lots 2001–2733; illustrated in color. Fine. **\$100**

Special Hardcover Edition, issued in very limited numbers. Ex John Dannreuther Library.

The Twin Leaf State Coinage

427 Stack's-Bowers Galleries. THE TWIN LEAF COLLECTION OF STATE COINAGE—CONNECTICUT & MASSACHUSETTS COPPERS. Baltimore, March 1, 2019. 4to, original black leatherette, gilt; original pictorial card covers bound in. vi, 182, (4) pages; lots 8000–8410; illustrated in color. Fine. **\$100**

Special Hardcover Edition, issued in very limited numbers. Ex John Dannreuther Library.

Robinson Brown Sale, with Photographic Plates

428 Superior Galleries. THE ROBINSON S. BROWN, JR. COLLECTION OF LARGE CENTS 1793–1857, CATALOGUED BY JACK COLLINS. West Hollywood, Sept. 30–Oct. 1, 1986. 4to, original processed crimson full leather, gilt; leatherette slipcase. (10), 306, (4) pages; 1457 lots; text illustrations; 6 color halftone plates; 40 fine mounted photographic plates of large cents. Prices realized list laid in. Rubbing to jacket, as usual, else fine. **\$100**

The Special Extra-Illustrated Leatherbound Edition of this landmark collection. Ex Roger Persichilli Library.

Signed by Buddy Ebsen

429 Superior Galleries. THE BUDDY EBSEN COLLECTION AND OTHER FINE PROPERTIES. Century City, May 31–June 2, 1987. 4to, original blue cloth, gilt; jacket. (10), 352, (2) pages; 3211 lots; text illustrations; 14 color halftone plates. Signed by Ebsen on flyleaf. Jacket and covers a bit rubbed; near fine. **\$100**

The Special Hardbound Edition. Scarce, and signed by the popular actor. Ex John Dannreuther Library.

Jack Robinson Sale, with Photographic Plates

430 Superior Galleries. THE JACK H. ROBINSON COLLECTION OF LARGE CENTS AND HALF CENTS. Beverly Hills, Jan. 29–30, 1989. 4to, original processed brown full leather, gilt; jacket; leatherette slipcase. (10), 360 pages; 2021 lots; text illustrations; 6 color plates; 40 fine mounted photographic plates of large cents. Signed promotional piece and prices realized list laid in. Rubbing to jacket, as usual, else fine. **\$100**

The Special Extra-Illustrated Leatherbound Edition of this highly important collection. Ex Roger Persichilli Library.

Photographically Plated Cohen Sale

431 Superior Galleries. THE ROGER S. COHEN, JR. COLLECTION OF HALF CENTS. Beverly Hills, February 2, 1992. 4to, original tan-gray cloth, lettered in copper; embossed color jacket. (10), (1), 79, (1) pages; 389 lots; portrait; numerous text illustrations; 1 halftone color plate; 6 fine monochrome photographic plates mounted and bound in. Prices realized list laid in. Light wear to jacket edges, else fine. **\$100**

The Special Hardcover Edition with six mounted photographic plates. Ex Roger Persichilli Library.

TAMS Journal Volumes, Bound

432 Token and Medal Society. TAMS JOURNAL: OFFICIAL ORGAN OF THE TOKEN AND MEDAL SOCIETY. Volumes 21–28 (1981–1988), bound in eight volumes. 4to, later matching blue cloth, gilt; original printed card covers bound in. Fine. **\$120**

Eight bound volumes of this indispensable storehouse of information on American medals, tokens and related collectibles. Ex Richard E. Margolis Library.

The 1850 Mint Report

433 United States Government. MESSAGE OF THE PRESIDENT OF THE UNITED STATES, COMMUNICATING THE REPORT OF THE DIRECTOR OF THE MINT, SHOWING THE OPERATIONS OF THE MINT AND BRANCH MINTS DURING THE YEAR 1850. 31st Congress, 2d Session. Ex. Doc. No. 21. Washington, DC, February 4, 1851. 8vo, self-covered. 19, (1) pages. Removed from previous binding and somewhat stained. Good or better. **\$325**

The 1850 Mint Report, as transmitted by President Millard Fillmore and written by Mint Director Robert Patterson. The influx of gold from California is starting to be felt in earnest, and Patterson's comments on this subject are both interesting and important. After providing an overview of operations and production at the Philadelphia and branch mints, Patterson writes, "From these tables it may be perceived that the operations of the mints during the past year have been unprecedented in our history. The largest coinages before executed were in 1847 and in 1843—the total amount at all the mints being, in the former year, \$22,657,672; in the latter year \$11,967,830. But the coinage of 1850 exceeded that of 1847 by over \$11,000,000, and was nearly three times that of 1843. At the Philadelphia mint the coinage of the past year was nearly twice that of 1847, and over four times that of 1843. The increase in the proportion of our gold to our silver deposits, and the enormous amount of the former, derived from the mines of the United States, are deserving of especial notice. Of the bullion received the silver comprised less than a twentieth part of the whole value; and even of this small proportion as much as one-eighth was derived by separation from the California gold. Of the deposits of gold received, only about one thirty fifth part was in

foreign coins or bullion. The remainder, amounting to \$36,938,314, was of United States production, of which \$36,273,097 were from California. The entire receipts from that source, from the discovery of the mines to the close of 1850, were \$42,469,758." Mint Reports from this period are decidedly scarce. This is a very important Mint Report, reflecting the extraordinary effects of the Gold Rush on this nation's economy.

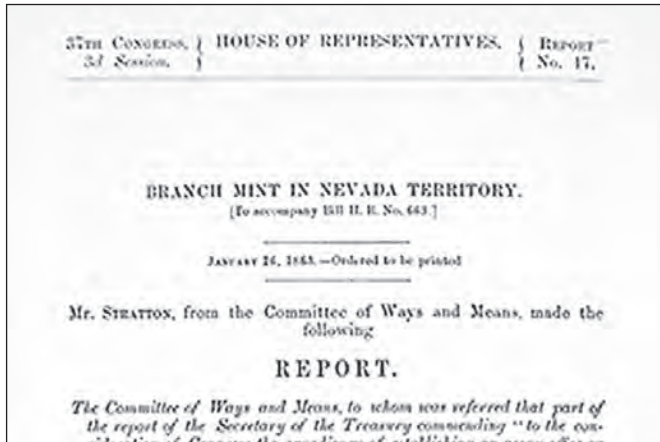

Suggesting a Mint at Carson City

434 United States Government. **BRANCH MINT IN NEVADA TERRITORY.** 37th Congress, 3d Session. Report No. 17. Washington, DC, January 26, 1863. 8vo, self-covered, as issued. 5, (3) pages. Removed from previous binding. Near fine. **\$250** Acting in response to Secretary of the Treasury Salmon P. Chase's exhortation to Congress to establish an assay office or branch mint in the Nevada Territory, the Committee of Ways and Means agreed that there was "an urgent necessity for a branch mint in said Territory" and concluded that "Carson city, from the fact that it is the central point of a vast area of mineral wealth, and that it is peopled by an industrious and loyal people, would indicate it as being the proper point for the establishment of a branch mint."

Vattemare's 1861 Catalogue

435 Vattemare, Alexandre. **COLLECTION DE MONNAIES ET MÉDAILLES DE L'AMÉRIQUE DU NORD DE 1652 À 1858, OFFERTE A LA BIBLIOTHÈQUE IMPÉRIALE TANT AU NOM DU GOUVERNEMENT FÉDÉRAL ET DES CITOYENS DES DIVERS ÉTATS DE L'UNION AMÉRICAINE QU'EN SON PROPRE NOM... CATALOGUE AVEC NOTICES HISTORIQUES ET BIOGRAPHIQUES.** Paris: Imprimerie de Ad. Lainé et J. Havard, 1861. 12mo, original printed russet paper covers. 134, (2) pages. Covers and binding reinforced with archival mending tissue. Good to very good. **\$120**

"Alexandre Vattemare is recognized among American numismatists as one of the fathers of the discipline in the New World, having assembled the first comprehensive collections of American coins, medals, and paper currency, and produced the first comprehensive catalog of American numismatics." — Alan Stahl, in *The Extravagant Ambassador: The True Story of Alexandre Vattemare, the French Ventriloquist Who Changed the World*. Vattemare developed the System of International Exchanges, initially aimed at the exchange of duplicate books between libraries, especially government publications, and later extended to include works of art, maps, natural history specimens, coins, medals and other similar objects. He came to America in 1839 and again in 1847, and was granted funds by Congress and by several state legislatures to further his scheme, which met with greater success here than in Europe.

This elusive 1861 work describing American coins, medals and tokens from 1652 to 1858 was written to complement the collection given to the Bibliothèque Impériale (Nationale) in the name of the government and citizens of the United States. Following an interesting historical overview, from colonial issues to pioneer gold, some 381 pieces are described in detail. Scarce and important. Ex Richard E. Margolis Library.

Vlack Plates on Machin's Mills Halfpennies

436 Venn, Theodore J. **LARGE UNITED STATES CENTS. A MONOGRAPH ON THE BIG COPPER "PENNIES" COINED BY THE U.S. GOVERNMENT FROM 1793 TO 1857.** Chicago: published by the author, 1915. 8vo, original card covers decoratively tied at the spine as issued. 31, (1) pages. Very good or better **\$100**

The first edition; one of only 300 copies issued. Of these, according to a 1931 letter from Venn to Michael Powells: "150 were distributed gratuitously to public libraries and book reviewers. Publication price was \$1 per copy and the edition was exhausted by 1916." Ex Roger Persichilli Library.

Vlack Plates on Machin's Mills Halfpennies

437 Vlack, Robert A. **EARLY ENGLISH COUNTERFEIT HALFPENCE STRUCK IN AMERICA. PHOTOS FROM COLLECTIONS OF A.N.S. - T. CRAIGE - E.P. NEWMAN - R.A. VLACK.** No place of issue, 1974 [probably later emissions]. Two 8 by 10 inch glossy photographic prints. Loose, accompanied by Mike Ringo's August 1991 listing of Machin's Mills die varieties with rarity ratings. Fine. **\$100**

Vlack published and distributed (on a rather small scale) photographic reference guides for a number of series for which good modern illustrated guides did not exist: Vermont coppers, Massachusetts cents and half cents, Washington military and draped bust pieces, the Voce Populi pieces, and perhaps others. These may have been the most important, though they are not the best-produced (the first plate seems invariably to be a bit blurry). Ex Roger Persichilli Library.



Finely Bound Large-Paper Copy, Priced

438 Woodward, W. Elliot. **PRICED CATALOGUE OF SELECTED SPECIMENS OF COINS AND MEDALS, FROM THE AMERICAN PORTION OF THE COLLECTIONS OF HENRY M. BROOKS, ESQ., JEREMIAH COLBURN, ESQ.,**

REV. J.M. FINOTTI, DR. EDWARD M. FIELD, AND DR. AUGUSTINE SHURTLEFF. New York: Bangs, April 28–May 1, 1863. 4to [32 by 26.5 cm], modern brown half speckled calf with marbled sides; spine with six raised bands, ruled and decorated in gilt; black and red spine labels lettered in gilt; marbled endpapers; original printed paper covers bound in. 112 pages, interleaved; 2569 lots; price realized printed alongside each lot. Store card section annotated in pencil. Fine. **\$500**

A lovely copy of the Special Interleaved Large Paper Edition. This important sale, Woodward's second semi-annual auction, is rated A by Adams and features superb colonials, Washingtonia, large cents, store cards, etc. Indeed, the sale was entirely composed of American numismatic items, and it totaled \$4,024.66, a new record. In his introductory comments, Woodward notes: "A few copies of this Catalogue, on large, extra fine and heavy paper, interleaved, can be furnished at \$2.00 each..." The annotations in the store card section, lots 1296–1819 (rated B+ by Adams), are most interesting, including corrections and expanded descriptions of some lots, an added lot (1503 1/2: "Idler, W. Head of Geo. Washington"), also added lots following 1666, 1688 & 1766, notes on metallic composition, and so forth. Adams 5. Attinelli 29.

Woodward's Plated "Montreal" Collection

439 Woodward, W. Elliot. CATALOGUE OF COINS, MEDALS AND DIES, FRACTIONAL CURRENCY, BOOKS, CATALOGUES, ETC. New York: Bangs, July 11–12, 1882. 8vo, original printed paper covers. 58 pages; 1386 lots; 1 fine heliotype plate. Rear cover taped; near fine. **\$150**

Adams 49, with plate. Printed on thick paper. Scarce. The plate depicts Washingtonia, a few rare United States silver dollars, and foreign pieces. Davis 1170. Ex Kolbe Sale 112, lot 316.

Plated Howard & Holstein Sale

440 Woodward, W. Elliot. REPRESENTATIVE OF ALL NATIONS. CATALOGUE OF A VERY EXTENSIVE COLLECTION OF GOLD, SILVER AND COPPER COINS AND MEDALS, PRINCIPALLY FROM THE CABINETS OF WINSLOW J. HOWARD AND FRANCIS HOLSTEIN. New York: Bangs, March 4–6, 1884. 8vo, original printed paper covers. 101, (1) pages; 2204 lots; 1 fine heliotype plate. Printed on thick paper. Unopened; very good or better. **\$150**

Adams 63, with plate. Woodward probably overdoes it by saying the sale contains "a greater number and larger variety of Coins, particularly in Copper, than was ever before offered at any one American Sale," but it does include some important pieces. Rated B overall, and for large cents, tokens, U.S. gold and the Americas in particular. Ex Kolbe Sale 112, lot 333.

One of 12 Copies Bound in Leather

441 Wright, John D. THE CENT BOOK: 1816–1839. St. Joseph, 1992. 4to, original full brown morocco, gilt; speckled page edges; silk marker. (28), 335, (3) pages; coin enlargements throughout the text; 27 plates of coins with text; rarity table. Inscribed and signed by the author. Fine. **\$500**

The rare special edition, No. 3 of only 12 thus bound. Dated 3 April 1992 and inscribed "For my friend, my advisor, my printer, and my distributor Wes Rasmussen / Who went well beyond the obligations of technical help to insure that The CENT Book became a book of which we both could be proud (signed) John D. Wright."

Sharp First Edition,

First Printing Red Book

442 Yeoman, R.S. A GUIDE BOOK OF UNITED STATES COINS. CATALOG AND PRICE LIST—1616 TO DATE... First (1947) edition, first printing. Racine: Whitman, 1946. 12mo, original red cloth, gilt. 254, (2) pages; text illustrations. Minor rubbing to binding, but with gilt well-preserved on both spine and front cover. Joints and hinges a bit weak, with rear hinge starting to crack slightly. Very good or better, but looks nearly fine. **\$450**

The first printing of the first edition, with strong gilt on the binding. Eighteen thousand copies of the first edition were issued, divided equally between the first and second printing. In the first printing, as here, the paragraph near the bottom of page 135 concludes with: "...the scarcity of this date." The second printing concludes with: "...the scarcity of 1903 O."

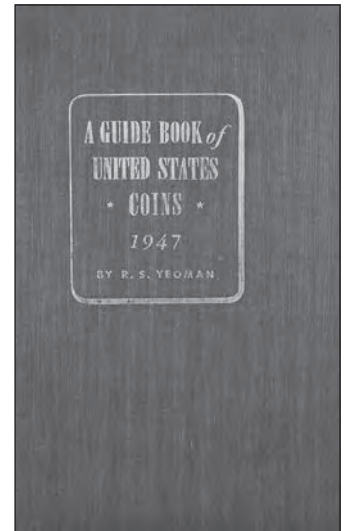

First Edition, Second Printing, Red Book with First Edition Blue Book

443 Yeoman, R.S. A GUIDE BOOK OF UNITED STATES COINS. First (1947) edition, second printing. Racine: Whitman, 1946. 12mo, original red cloth, gilt. 254, (2) pages; text illustrations. Gilt strong on front cover and moderate on spine. Corner bump; surface abrasions to pastedown and flyleaf from removal of label. Very good. [with] Yeoman, R.S., et al. HANDBOOK OF UNITED STATES COINS. First (1942) edition. Racine: Whitman, 1942. 12mo, original blue cloth, gilt. 126, (2) pages; text illustrations. Covers spotted. Very good or better. **\$350**

The second printing of the first edition, with very nice front cover gilt, along with a copy of the first edition of the familiar Blue Book.

Well-Preserved Second Edition Red Book

444 Yeoman, R.S. A GUIDE BOOK OF UNITED STATES COINS. 2nd (1948) edition. Racine: Whitman, 1947. 12mo, original red cloth, gilt. 254, (2) pages; text illustrations. Previous owner's signature on flyleaf. Cover gilt bright; spine sunned, with gilt mostly faded; sharp corners. Near fine. **\$150**

A very nicely preserved copy, though the spine is sunned: a pity, as it seem obvious the book was otherwise never used.

Four Early Editions

445 Yeoman, R.S. A GUIDE BOOK OF UNITED STATES COINS. 2nd (1948) edition. Racine: Whitman, 1947. 12mo, original red cloth, gilt. 254, (2) pages; text illustrations. Previous owner's signature and stamp. Very good. [with] Yeoman, R.S. A GUIDE BOOK OF UNITED STATES COINS. 4th (1951–1952) edition. Racine: Whitman, 1950. 12mo, original red cloth, gilt. 254, (2) pages; text illustrations. White endpapers. Near fine. [with] Yeoman, R.S. A GUIDE BOOK OF UNITED STATES COINS. 6th (1953–1954) edition. Racine: Whitman, 1952. 12mo, original red cloth, gilt. 254, (2) pages; text illustrations.

Previous owner's signature. Very good. [*with*] Yeoman, R.S. A **GUIDE BOOK OF UNITED STATES COINS**. 8th (1955) edition. Racine: Whitman, 1954. 12mo, original red cloth, gilt. 254, (2) pages; text illustrations. Good. **\$200**

The 2nd, 4th, 6th and 8th editions. The 2nd edition is a decent copy, with above-average cover gilt, and the 4th edition is rather nice.

Fourth Edition, Inscribed by Yeoman

446 Yeoman, R.S. A **GUIDE BOOK OF UNITED STATES COINS**. 4th (1951–1952) edition. Racine: Whitman, 1950. 12mo, original red cloth, gilt. 254, (2) pages; text illustrations. White endpapers. Inscribed "To my very good friends the Morrises" and signed by R.S. Yeoman opposite the title page. Front gilt fairly bright; spine gilt faded. Nick to fore-edge. Still very good or better. [*with*] Yeoman, R.S. A **GUIDE BOOK OF UNITED STATES COINS**. 3rd (1949–1950) edition. Racine: Whitman, 1948. 12mo, original red cloth, gilt. 254, (2) pages; text illustrations. Gilt faded and covers discolored; binding weak. Good. **\$150**

A nice inscribed copy of the fourth edition, with an accompanying (uninscribed) third edition.

Nicely Preserved Fifth Edition Red Book

447 Yeoman, R.S. A **GUIDE BOOK OF UNITED STATES COINS**. 5th (1952–1953) edition. Racine: Whitman, 1951. 12mo, original red cloth, gilt. 254, (2) pages; text illustrations. Strong gilt on front cover and mostly bright on spine; a very small damp stain is seen on the fore-edge of the front cover, lightly reddening the page edges. Else near fine. **\$300**

The fifth edition is generally regarded as being the second toughest to obtain, and is rarely seen in fine condition. The damp-stain mentioned is minor, and is the only real flaw in what is otherwise a fine copy with sharp corners.



1835 Large Date,			
Small 5c	1.50	3.00	6.00 6.50 7.50
1835 Small Date,			
Large 5c	1.50	3.00	6.00 6.50 7.50
1835 Small Date,			
Small 5c	1.50	3.00	6.00 6.50 7.50
1836 Small 5c	1.50	3.00	6.00 6.50 7.50
1836 Large 5c	1.50	3.00	6.00 6.50 7.50
1837 Small 5c	1.50	3.00	6.00 6.50 7.50
1837 Large 5c	1.50	3.00	6.00 6.50 7.50
1838 No Drapery	1.25	3.00	8.00 9.00 10.00
1839 No Drapery	1.25	3.00	8.00 9.00 10.00
1839 No			
Drapery	1.50	4.00	9.50 10.50 11.50
1840 No Drapery	1.25	3.00	8.00 9.00 10.00
1840 No			
Drapery	2.50	7.50	14.00 16.00 18.00
1837 No Stars,			
Sm. Date	6.50	12.50	32.50
1837 No Stars,			
Lg. Date	6.50	12.50	32.50
1838 No Stars	12.50	22.50	60.00

Aubrey Bebee's Annotated Contributor Copy in a Blank Binding

448 Yeoman, R.S. A **GUIDE BOOK OF UNITED STATES COINS**. 11th (1958) edition. Racine: Whitman, 1957. 12mo, original red leatherette, gilt. 254, (2) pages; text illustrations. Extensively annotated in ink by Aubrey Bebee from page 59 to the end (the federal coinage and following). The binding is the usual red leatherette, but is completely blank: no gilt at all. Endpapers discolored. Very good. **\$300**

A fascinating contributor's copy, the first we recall seeing in this form. The book itself is simply a regular 11th edition Red Book: it is not in-

terleaved, inscribed, or anything else. The binding, however, is plain red leatherette, identical to any other 11th edition Red Book except that it is blank, with no gilt on it at all. While we have seen copies as early as the 15th edition with similarly blank covers, those copies were interleaved. This copy has been used by Aubrey Bebee to update the pricing information for the 12th edition Red Book. His name is not in it, but our consignor purchased it from Orville Grady, who had acquired a large number of books from the Bebees, including this one.

Special Interleaved Edition Red Book

449 Yeoman, R.S. A **GUIDE BOOK OF UNITED STATES COINS**. 20th (1967) edition. Racine: Whitman, 1966. 12mo, original plain red leatherette; spine stamped GUIDE / BOOK / 1967 in gilt. 255, (1) pages; text illustrations; interleaved. Fine. **\$150**

A very well-preserved copy of the Special Interleaved Edition, intended for use by contributors in preparing the next edition. Very scarce.

Inscribed to Joe Person

450 Yeoman, R.S. A **GUIDE BOOK OF UNITED STATES COINS**. 22nd (1969) edition. Racine: Western, 1968. 12mo, original red leatherette, gilt. 255, (1) pages; text illustrations. Inscribed and signed by R.S. Yeoman to contributor Joe Person on the front flyleaf. Spine worn; very good. [*with*] Yeoman, R.S. A **GUIDE BOOK OF UNITED STATES COINS**. 26th (1973) edition. Racine: Western, 1972. 12mo, original red leatherette, gilt. 255, (1) pages; text illustrations. Inscribed and signed by R.S. Yeoman to contributor Joe Person on the front flyleaf. Near fine. **\$120**

Inscribed contributor copies of the 1969 and 1973 editions. Both inscribed to contributor Joe Persons.

Inscribed Contributor Copies

451 Yeoman, R.S. A **GUIDE BOOK OF UNITED STATES COINS**. 23rd (1970) edition. Racine: Western, 1969. 12mo, original red leatherette, gilt. 255, (1) pages; text illustrations. Inscribed and signed by R.S. Yeoman to contributor Paul Kagin on the front flyleaf. A worn copy, with some signatures loose; good. [*with*] Yeoman, R.S. A **GUIDE BOOK OF UNITED STATES COINS**. 25th (1972) edition. Racine: Western, 1971. 12mo, original red leatherette, gilt. 255, (1) pages; text illustrations. Inscribed and signed by R.S. Yeoman to contributor Art Kagin opposite the title page. A worn copy, with some signatures loose; good. **\$100**

Inscribed contributor copies of the 1970 and 1972 editions. Worn copies, but with fine inscriptions.

Signed by Dick & Marion Yeoman

452 Yeoman, R.S. A **GUIDE BOOK OF UNITED STATES COINS**. 30th (1977) edition. Racine: Western, 1976. 12mo, original red leatherette, gilt. 256 pages; text illustrations. Signed by R.S. Yeoman and Marion Yeoman on the flyleaf. Near fine. **\$100**

An unusual copy, the first we recall seeing signed by Yeoman's wife Marion. (While the couple's name was actually Yeo, she signed her name Yeoman here to match her husband's penname.)

Signed by Yeoman & Bressett for Chet Krause

453 Yeoman, R.S. A **GUIDE BOOK OF UNITED STATES COINS**. 32nd (1979) edition. Racine: Western, 1978. 12mo, original red leatherette, gilt. 256 pages; text illustrations. In-

scribed to Chet Krause and signed by R.S. Yeoman on the flyleaf, and signed by Ken Bressett on the title page. Fine. **\$100**
A dual-signed Red Book inscribed to one of the hobby's giants.

Sewn, but Unglued & Unbound Red Book

454 Yeoman, R.S. A GUIDE BOOK OF UNITED STATES COINS. 34th (1981) edition. Racine: Western, 1980. 12mo, sewn with endpapers in place, but neither glued nor bound. 256 pages; text illustrations. First signature starting to come loose; near fine. **\$100**

A rarely seen unbound copy of the ubiquitous Red Book, sewn and with the endpapers in place, ready to be glued and bound. The front and back outer pastedowns are printed to assist in making sure copies were bound properly. This is the only unbound copy we recall seeing that wasn't even glued at the spine.

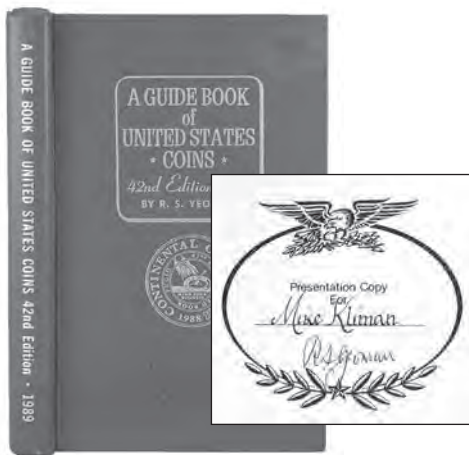

The Final Edition Signed by Yeoman

455 Yeoman, R.S. A GUIDE BOOK OF UNITED STATES COINS. 42nd (1989) edition. Racine: Western, 1988. 12mo, original red leatherette, gilt. 270, (2) pages; text illustrations. Limitation leaf inscribed to Mike Kliman and signed by R.S. Yeoman tipped in before front flyleaf. Fine. **\$100**

Richard Sperry Yeo, known to the coin world as R.S. Yeoman, died on November 9, 1988, at the age of 84. This Presentation Edition was signed to contributor Mike Kliman.

1992 ANA Edition

456 Yeoman, R.S. A GUIDE BOOK OF UNITED STATES COINS. 45th (1992) edition. Racine: Western, 1991. 12mo, original red leatherette, gilt. 286, (2) pages; text illustrations. ANA 100th Anniversary Edition. Fine. **\$150**
Distributed at the 1992 ANA Banquet. Discussed by Colletti (page 225).

50th Anniversary Binding, Signed to a Contributor

457 Yeoman, R.S. A GUIDE BOOK OF UNITED STATES COINS. 50th (1997) edition. Racine: Western, 1996. 8vo, original burgundy leatherette, gilt. Limitation leaf; 328 pages; illustrated. Inscribed to Paul (Kagin) by and signed by Ken Bressett on the title page. Bump to top edge of front cover; near fine. **\$100**

Number 63 of only 1200 produced of the 50th anniversary edition special binding, inscribed to a contributor.

2005 FUN Edition, Signed by Bressett

458 Yeoman, R.S. A GUIDE BOOK OF UNITED STATES COINS. 58th (2005) edition. Atlanta: Whitman, 2004. 8vo, original red leatherette, gilt. 384 pages; illustrated. Signed by Ken Bressett and dated "FUN '05" on the flyleaf. Fine. **\$100**

A special edition cover distributed at this popular coin show. While Colletti reports that around 1100 copies were thus bound, few of them were signed by editor Ken Bressett, as was this one.

With the Original Banquet Program

459 Yeoman, R.S. A GUIDE BOOK OF UNITED STATES COINS. 60th (2007) edition. Atlanta: Whitman, 2006. 12mo, original red leatherette, gilt. 414, (2) pages; illustrated in color. Fine. Original program for the November 25, 2006 Michigan State Numismatic Society banquet included. **\$100**

Special edition. One of 450 copies issued for the Michigan State Numismatic Society in honor of their 50th anniversary and bearing a special cover design.

END OF SALE • THANK YOU

Ancient Coins in Early American Auctions, 1869–1939

By David F. Fanning

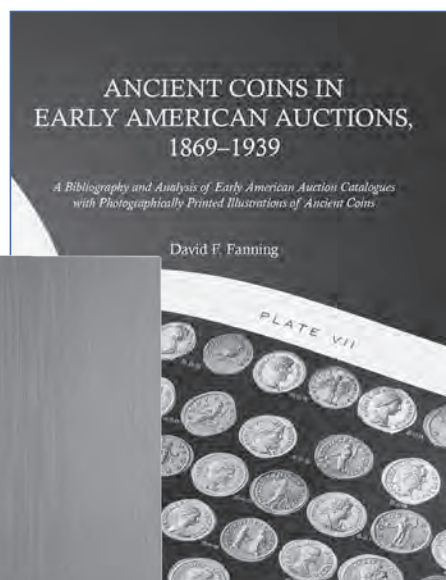

A bibliography and analysis of American auction catalogues issued before the Second World War that feature photographically printed illustrations of ancient coins. Includes biographical material concerning the dealers whose catalogues are discussed, as well as a statistical analysis of the catalogues and supplementary information relevant to provenance research. Visit numislit.com for more information.

Available now for \$75

Deluxe edition, limited to 10 copies, bound in blue quarter morocco with gray Japanese cloth sides; spine with five raised bands, ruled, lettered and decorated in gilt; hand-marbled endpapers. Available now for \$500.

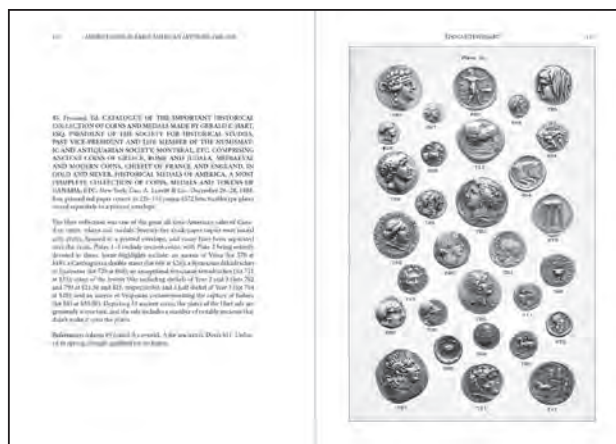
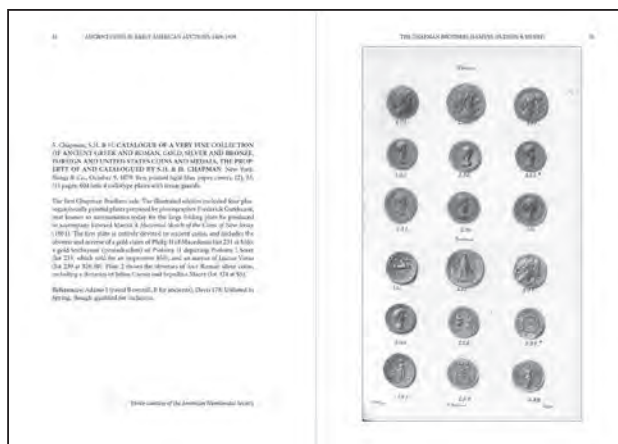

Praise for Ancient Coins in Early American Auctions, 1869–1939

“fills an immediate need for the serious collector and dealer of ancient coinage”

Kerry K. Wetterstrom
Senior Numismatist, Classical Numismatic Group

“brings to light an area of American numismatic history that has long been forgotten”

Q. David Bowers
Founder, Stack's Bowers Galleries

“Ancient Coins in Early American Auctions, 1869–1939 belongs in the library of all ancient coin collectors. The bios, the many plate photos, the tables and lists have a broad appeal and will be of major interest to all early American auction catalogue collectors as well.”

Dan Hamelberg
Collector

“a welcome addition to the study of pedigrees on ancient coins as well as an important chapter in the history of collecting”

Ed Waddell,
Edward J. Waddell, Ltd.

“an outstanding example of in-depth research on a subject that was in serious need of attention”

“indispensable for both the researcher and the serious collector”

“a classic in every sense of the word”

Basil C. Demetriadi
Collector and Researcher

“Collectors of ancient coins will find this well-illustrated volume essential for provenance research, and numismatists in general will enjoy a guided tour through the world of 19th-century American coin dealers.”

Joel J. Orosz
Numismatic Author and Historian



Kolbe & Fanning
Numismatic Booksellers
numislit.com



Kolbe & Fanning
 Numismatic Booksellers
numislit.com

Hundreds of numismatic titles available for direct purchase in our online bookstore

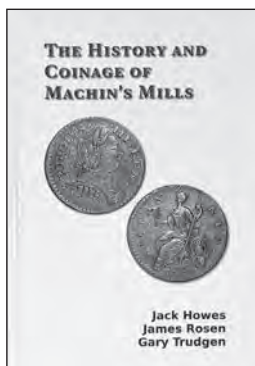

Jack Howes, James Rosen and Gary Trudgen
 Colonial Coin Collectors Club

THE HISTORY AND COINAGE OF MACHIN'S MILLS.

The first book-length study of the intriguing series of coppers issued by various parties associated with Thomas Machin. **\$65**

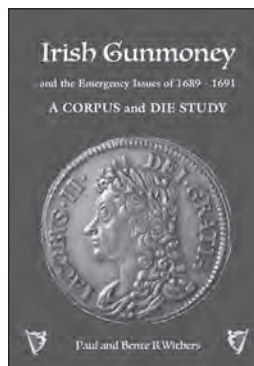

Paul and Bente R. Withers

IRISH GUNMONEY AND THE EMERGENCY ISSUES OF 1689-1691: A CORPUS AND DIE STUDY.

A thorough and well-illustrated new work on these fascinating issues, with additional contributions by John Rainey, David Greenhalgh and Garry Oddie. **\$150**

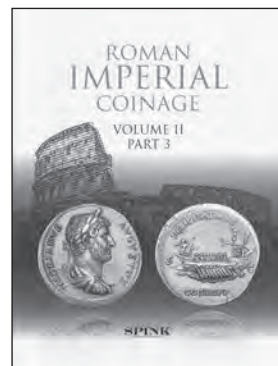

R.A., Abdy and P.F. Mittag

THE ROMAN IMPERIAL COINAGE. VOLUME II—PART 3, FROM AD 117-138 HADRIAN.

The newly published volume of the RIC series on the issues of Hadrian, completely replacing the coverage of this emperor in the earlier RIC Volume II. **\$195**



Peter Van Alfen and Ute Wartenberg

WHITE GOLD: STUDIES IN EARLY ELECTRUM COINAGE.

A landmark publication on the topic of the earliest coinage, bringing together current scholarship from more than two dozen researchers and covering every aspect of these pieces. Includes a die study by Wolfgang Fischer-Bossert. **\$150**

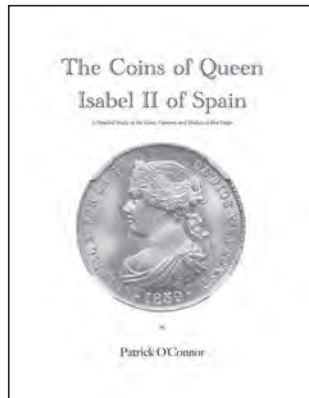

Stack's Bowers Galleries, with Sotheby's

THE COINS OF QUEEN ISABEL II OF SPAIN: A DETAILED STUDY OF THE COINS, PATTERNS, AND MEDALS OF HER REIGN.

The standard work on the coins and medals of this fascinating ruler, who reigned from 1833 to 1868. Extensively illustrated in color, this will remain the standard work on the subject for quite some time. **\$95**

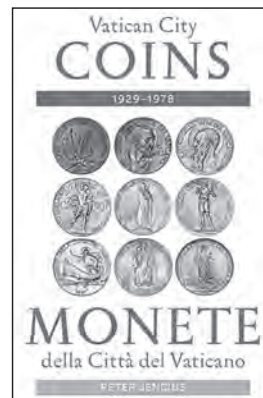

Peter Jencius

VATICAN CITY COINS: 1929-1978

Clearly explains Vatican monetary conventions, investigates data as to when annual issues were actually produced, and considers how coins were packaged for collectors. **\$35**



The source for new, rare and out-of-print numismatic books

*Connect with your
fellow bibliophiles*

Join the
**Numismatic
Bibliomania Society**

The Numismatic Bibliomania Society (NBS) is an educational association founded in 1979 to support and promote the use and collecting of numismatic literature.



The Asylum
quarterly print journal

The E-Sylum
weekly free electronic publication

NBS Bibliotalk
podcast with Lianna Spurrier

COINBOOKS.ORG



BID SHEET

SALE 160
 BID.NUMISLIT.COM
May 22, 2021
Absentee bids due
Friday, May 21, 2021

Kolbe & Fanning
Numismatic Booksellers
 141 W. Johnstown Road
 Gahanna, OH 43230-2700 USA
 (614) 414-0855 • FAX: (614) 414-0860
 df@numislit.com • numislit.com

NAME _____

ADDRESS _____

PHONE _____

EMAIL _____

Please execute the following bids. The prices affixed are the highest I will pay. It is understood that you will buy for me as much below my bids as possible. For any purchases you may make for me I herewith agree to pay you promptly in accordance with the Terms of Sale as printed in the Sale Catalogue. Parties who have not established credit must send a deposit of 25% of their bids or include suitable trade references or credit card data.

I authorize my bids to be increased by 10% __, 20% __, or __% if necessary

SIGNATURE _____

CREDIT CARD AUTHORIZATION

MasterCard American Express
 VISA Discover Diners Club

CC NUMBER _____

EXP DATE _____ CVV _____

A 20% BUYER'S PREMIUM WILL BE ADDED TO COST OF ALL LOTS

LOT NO.	DESCRIPTION	BID	LOT NO.	DESCRIPTION	BID

BIDDING INCREMENTS:

- \$5 to \$95 — \$5 increments
- \$100 to \$190 — \$10 increments
- \$200 to \$475 — \$25 increments
- \$500 to \$950 — \$50 increments
- \$1000 to \$1900 — \$100 increments
- \$2000 to \$4750 — \$250 increments